

BS-100 *DYFI*



Installation handbook



Contents

Please observe!

This handbook contains installation instructions for fire alarm system BS-100 DYFI ready designed and assembled from the factory.

If the system is to be expanded on site, please see separate booklets concerning internal mounting, internal connections, switch settings, commissioning a.s.o.

	Page
1. Mounting	4
1.1 Location	4
1.2 Wall (bulkhead) mounting.....	4
1.2.1 Release the electronic cassette.....	4
1.2.2 Mounting height	5
1.2.3 Mounting holes.....	5
1.2.4 Fasten screws.....	6
1.2.5 Cable inlets	6
1.2.6 Cable outlets	7
1.2.7 Cable length.....	7
1.3 Flush mounting.....	7
1.3.1 Cut-out.....	7
1.3.2 Flush mounting in a wall	8
1.3.3 Flush mounting of cabinet in a wall	8
1.3.4 Cable insertion.....	9
1.4 Cut-out and flush mounting in a (control) desk.....	9
1.5 Mounting in a 19" rack.....	10
2. Connections.....	11
2.1 Connection on List 1 and List 2.....	12
2.2 Connection on List 3	13
2.3 Connection on List 10 and List 20.....	14
3. Expansion modules.....	15
3.1 External connections to optional detector loop module BSD-100.....	15
3.2 External connections to optional alarm output module BSB-100.....	16
3.3 External connections to optional control output module BSJ-100 / BSJ-101.....	17
3.4 External connections to optional data output module BSL-100	18
3.4.1 Connection of peripheral data equipment to the BSL-100 module.....	18
3.4.2 Table of connections between data output module BSL-100 and Autronica manufactured peripheral equipment	20

Mounting

1. Mounting

Location

1.1 Location

The control panel is to be located in, or near by, the entrance according to local regulations and in consultation with the fire brigade (fire fighters).

Wall / bulkhead

1.2 Wall (bulkhead) mounting

The BS-100 *DYFI* panel is delivered as standard in two types of steel plated cabinets:

Cabinet UEA-22/1 and UEA-23/1 for panels with up to two detector loops, (max. 198 addresses).

Cabinet UEA-22/2 and UEA-23/2 for panels with more than two detector loops, (more than 198 addresses).

The difference between UEA-22 and UEA-23 is the depth.

1.2.1 Release the electronic cassette

Release the electronic cassette by unscrewing the four screws on the front frame. See fig. no. 1. The cassette including the front door can now be lifted out of the cabinet.

If the cassette is fixed to the cabinet, bend it out carefully by using a screw driver.

Fig. no. 1: Front frame screws

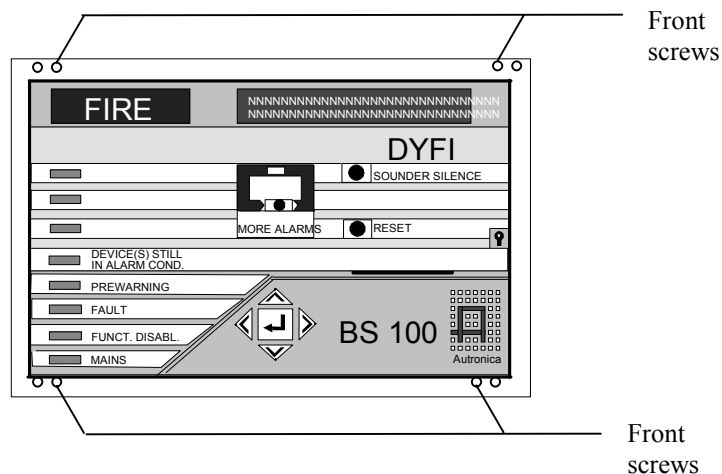

Mounting height

1.2.2 Mounting height

The recommended mounting height of the panel top is 180 cm above the floor due to optimal readability of the texts in the display.



In order to open the front door completely, there must be a free space of min. 450 mm on the left hand side of the panel.

1.2.3 Mounting holes

The cabinets have four (4) mounting holes located at the rear wall. The two upper holes are of the “key-hole” type. See fig. no. 2a, (for cabinet UEA-22/1 and UEA-23/1) and fig. no. 2b (for cabinet UEA-22/2 and UEA-23/2).

Mark and drill holes for fixing screws and plugs (max. 6 mm screws). See fig. no. 2a and 2b. Partly fasten the two upper screws.

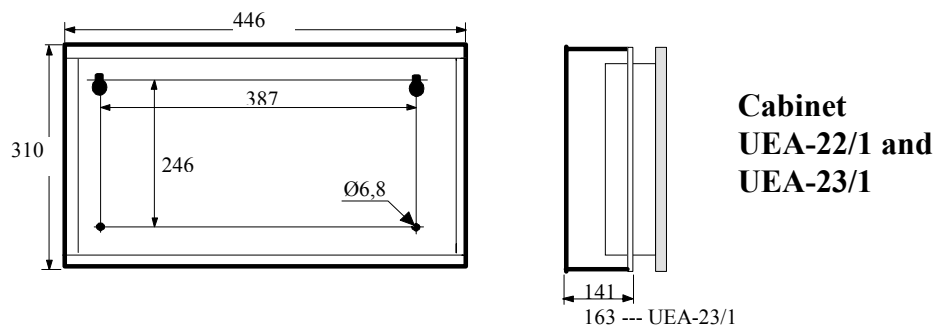

Fig. no. 2 a: Cabinet dimensions

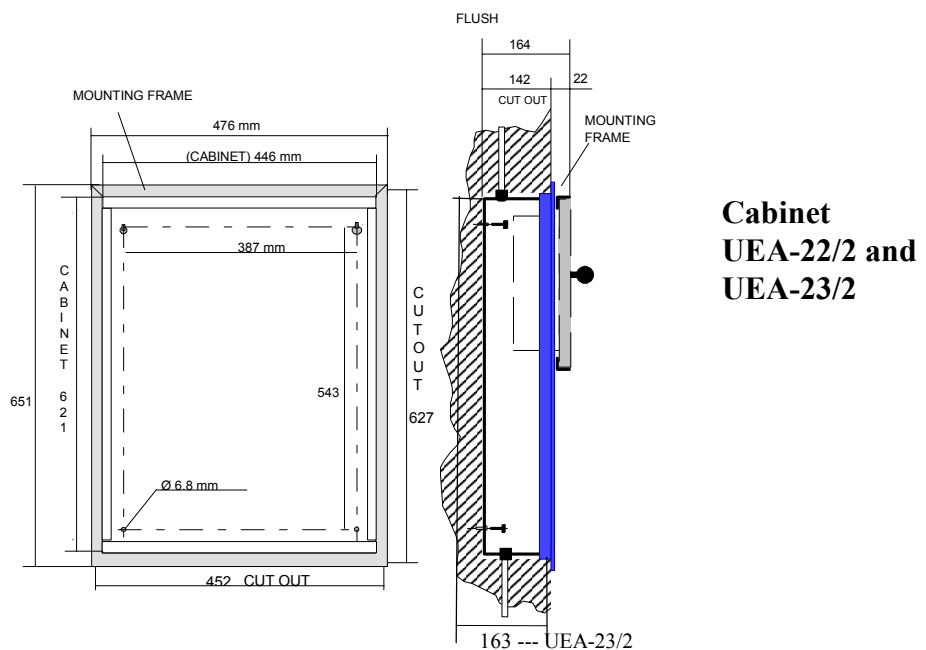

Fig. no. 2 b: Cabinet dimensions

Please observe: The three small holes at the front of the four cabinet sides are intended for mounting a cover frame used when the cabinet is to be flush-mounted. See section 1.3.2.

1.2.4 Fasten screws

Hang the cabinet to the two upper screws and check that the cabinet is angularily mounted. Fasten the two lower screws, and tighten all four screws.

1.2.5 Cable inlets

Feed all cables into the cabinet from the top and / or bottom through the suitable cable inlets. See fig. no. 3.



In the fixed mains wiring to the panel a two-pole disconnect device shall be provided to disconnect the equipment from the supply for servicing.

When feeding cables into the cabinet from the bottom side, the following precautions must be taken.

- The mains cable must be fed through the cable inlet at the very left hand side.
- All other cables should be fed through the successive inlets. Let the thinnest cables be fed through the rightmost inlets.
- If cables are fed into the cabinet from the top, all cables must be put closely to the cabinet rear wall, guided to the bottom and bent out to the front.
- All cables fed into the cabinet must have a minimum length of 1 m inside the cabinet.

Cable inlet holes

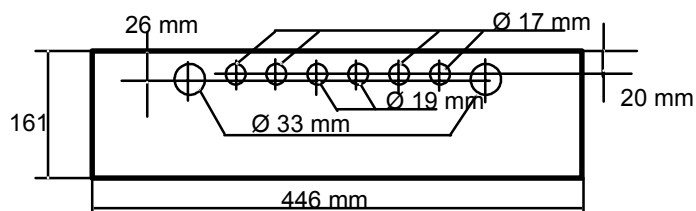

Fig. no. 3: Cable inlet holes.

1.2.6 Cable outlets

All cables are guided through the open space at the lower left hand side of the electronic cassette. Then the cassette is mounted and the fixing screws are fastened. See fig. no. 1.

Cables fed into the cabinet from the top are now partly hidden behind the cassette.

1.2.7 Cable length

The cables' length are adjusted according to the appropriate terminals, then stripped and connected. See section 2.1, 2.2, 2.3, 2.4 and 2.5.

Flush mounting

1.3 Flush mounting

Cut-out

1.3.1 Cut-out

Cut-out for mounting of the cabinet in a wall. See fig. no. 4.

Before the cabinet is mounted, remove the electronic cassette as described in section 1.2.1.

The dimensions given include space for the cover frame. See fig. no. 5.
Cables are fed into the cabinet from the top and / or from the bottom.

Cabinet UEA-22/1 and UEA-23/1

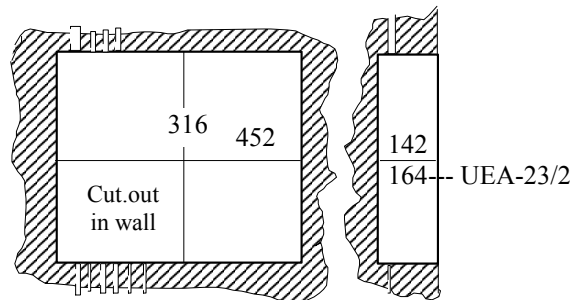

Cabinet UEA-22/2 and UEA-23/2

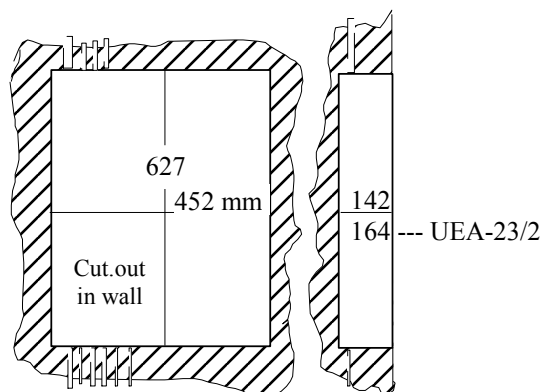

Fig. no. 4

Cut-out and cable inlets, both types of cabinet

In a wall

1.3.2 Flush mounting in a wall

Flush mounting of cabinet in a wall.

If a flush mounting is planned before construction of the wall, the cabinet can be used as casting form for the wall. The cover frame must be mounted and the electronic cassette must be removed. The cover frame is fixed by means of "POP"-riveting.



Please observe that the cabinet must be supported before concreting to avoid deformation.

The cable tubes needed are fed into the cabinet by means of a socket joint.

1.3.3 Flush mounting of cabinet in a wall

Mounting of cabinet in a wall. See fig. no. 5.

Cover frame for flush mounting of cabinet UEA-22/1 and UEA-23/1 = UE-818/L.

Cover frame for flush mounting of cabinet UEA-22/2 and UEA-23/2 = UE-818/H.

Cabinet UEA-22/1 and UEA-23/1**Cabinet UEA-22/2 and UEA-23/2**

Fig. no. 5: Dimensions, cabinets mounted in a wall

19" rack

1.5 Mounting in a 19" rack

When the control panel is to be mounted in a control desk, two (2) mounting brackets type UE-814 must be used.
 The control panel is mounted without the cabinet.
 The mounting brackets are fixed to the electronic cassette with two screws M5 mm in each bracket as shown in fig. no. 7.
 The figure shows the cut-out dimensions and the location of the fixing holes.
 When all cables are fed into the rack, the control panel with the mounting brackets is put into the rack and fastened.

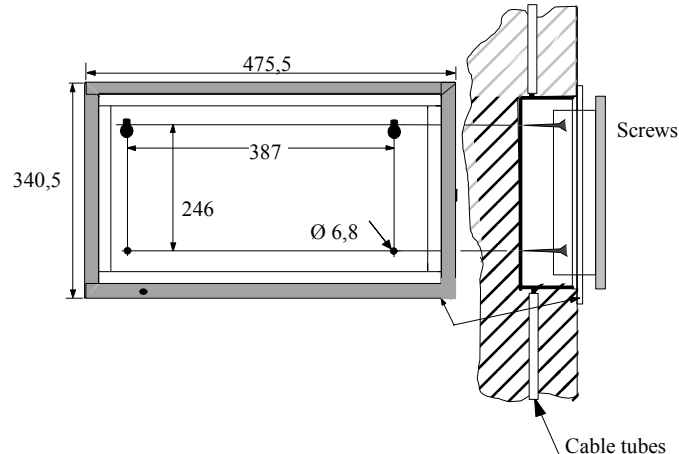
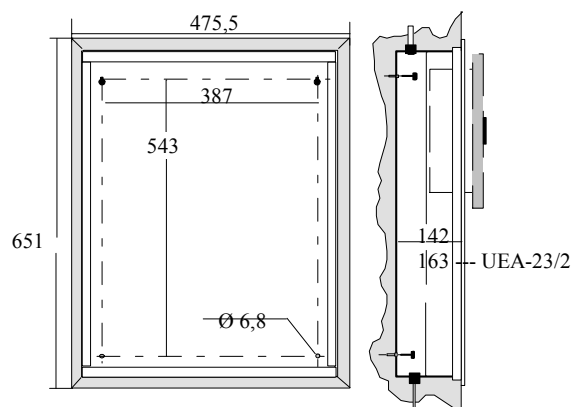
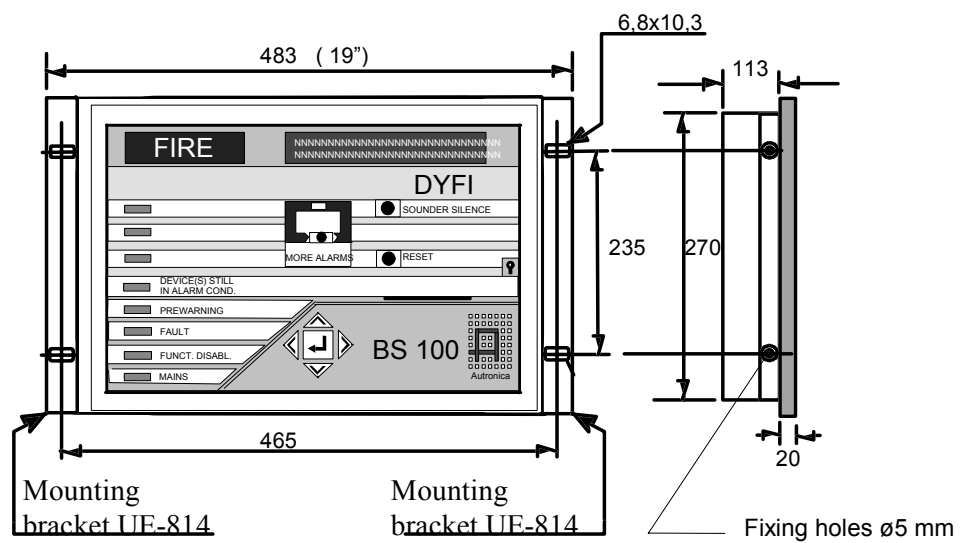

Fig. no. 7: Dimensions (incl. mounting bracket) for mounting in a 19" rack.

Connections



2. Connections

Remove fuses F1 and F2 before any connection work!

Location of fuses and terminal blocks (list 1, list 2, list 3, list 10 and list 20) are clearly indicated on the main board cover. See fig. no. 8.

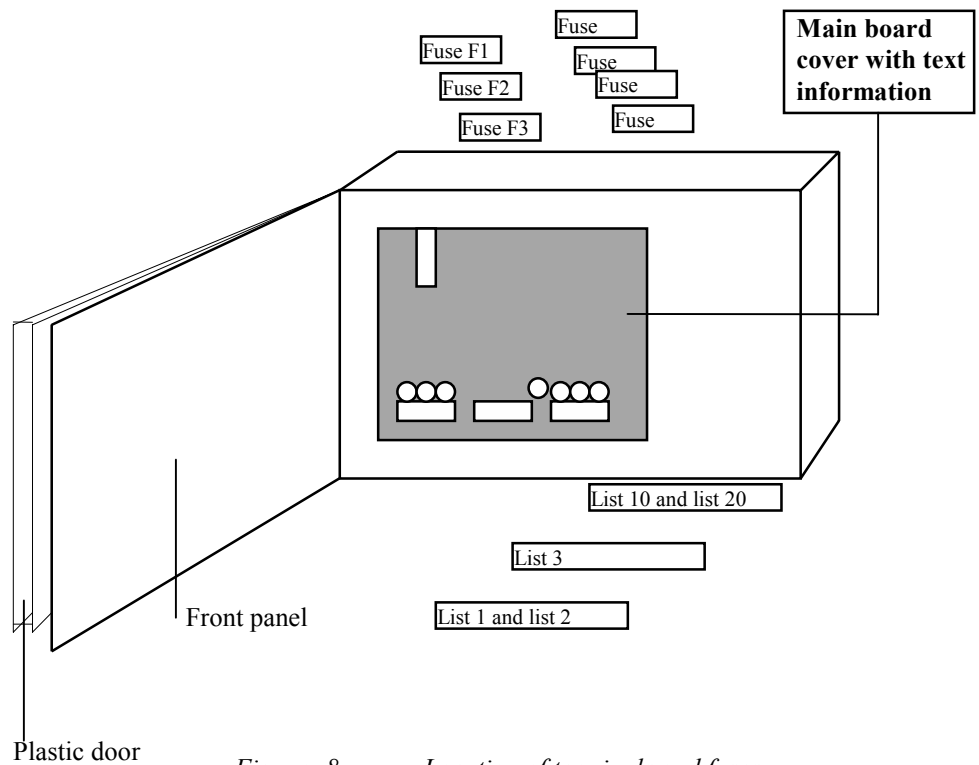

Fig. no. 8: Location of terminals and fuses

Fuses

Fuses	Size	Type	Protecting
F1	1,4A	Slow	Mains
* F2	6,3A	Fast	Battery
F3	1A	Slow	External 24V DC
** F31	1A	Fast	Alarm output 1
** F32	1A	Fast	Alarm output 2
** F33	1A	Fast	Alarm output 3
** F34	1A	Fast	Alarm output 4

All fuses are located on the main board just above the terminals.

* For Chinese Market - 2,5A

** For Chinese Market - 0,250A

List 1 and 2

2.1 Connection on List 1 and List 2

Mains, chassis (earth), battery, test output (internal function) and power output 24 V DC.

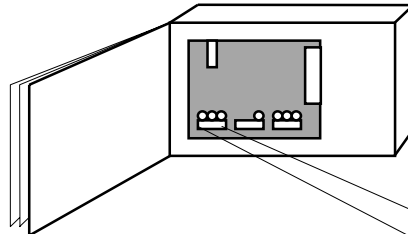

Function	External connection	List 1	Internal function
Chassis (earth)		Ø 1	
230 V AC, Mains		Ø 2	
230 V AC, Mains		Ø 3	
		List 2	
Accumulator (battery)	BATT +	Ø 4	
	BATT -	Ø 5	
Internal function	Test	Ø 6	
24 V DC output Max. load 1 A	Ext. 24 V DC	+ Ø 7 Ø 8	“Ext. 24 V” and “DHM+” list 3 have common fuse F3 (1A)

Fig. no. 9: Connections on List 1 and List 2



The fire alarm control panel shall not be connected to the mains and battery, and the removed fuses shall not be installed until commissioning of the system.

List 3

2.2 Connection on List 3

Various inputs / outputs; group disablement, external alarms, relay contacts, general alarm, electromatic door holders and “quiet” (delayed) alarm input.

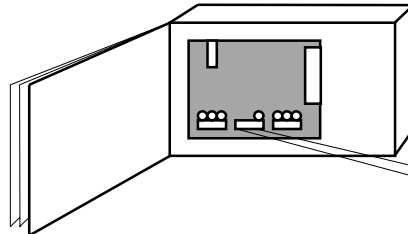

Function	External connection	List 3	Internal function
Special domestic (national) functions		0 V SP	Ø 9 Ø 10 Common 0V. Output (open collector)
Alarm organization		D / N	Ø 11 Delayed alarm signal
Monitoring of external equipment		E	Ø 12 Fault signal. When used, cut strap W13
General alarm		GA	Ø 13 Steady signal to all “Alarm outputs”
Group disabling 1 Group disabling 2 Group disabling 3		1 GRU 2 3	Ø 14 Ø 15 Ø 16 Disable groups of detectors. Freely programmeable.
Electromagnetic door holder(s)	Max. 1A at 24VDC 	+ DHM -	Ø 17 Ø 18 “Ext. 24V” (list 2) and “DMH+” have common fuse, F3 (location: + leader)
Changes at fire alarm condition	Max. 1A at 24VDC	AUX	Ø 19 Ø 20 Ø 21
Changes at fire alarm condition	Max. 1A at 24VDC	BMA	Ø 22 Ø 23 Ø 24

Fig. no. 10: Connections on list 3

List 10 and 20

2.3 Connection on List 10 and List 20

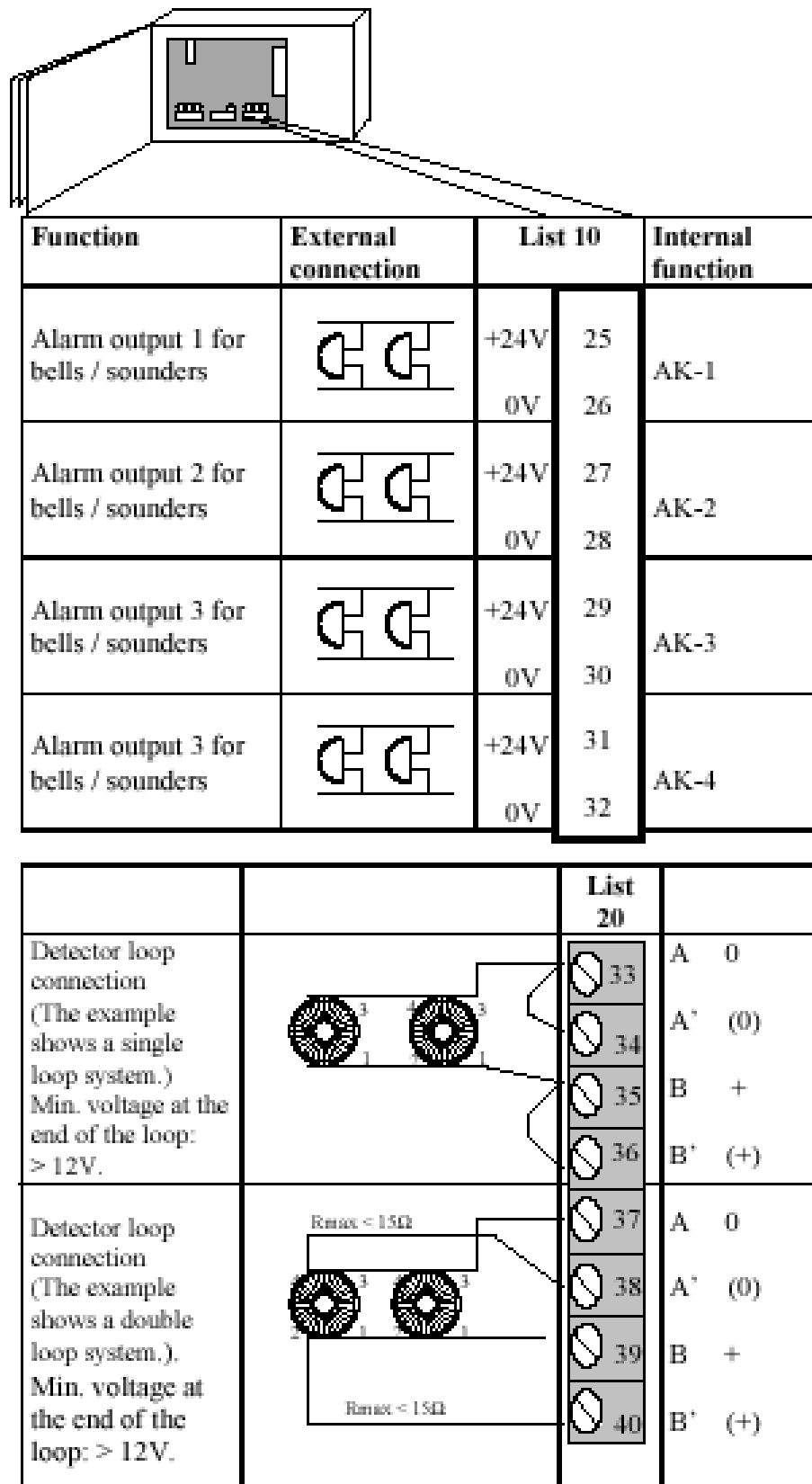

Fig. no. 11: Connections on List 10 and 20.

Expansion

3. Expansion modules

Detector loop module BSD-100

3.1 External connections to optional detector loop module BSD-100

The module features two optional detector loops. Each loop has a capacity of max. 99 addresses.

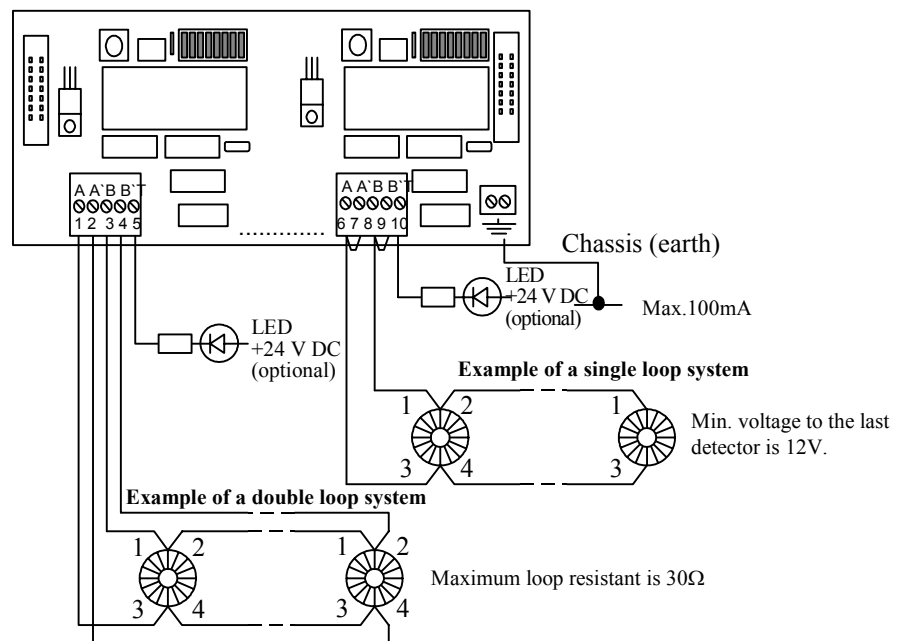

Fig. no. 12: External connections on BSD-100

The figure shows two different types of loop connections: The double loop system and the single loop system. The two types of loop systems can both be connected to either of the two terminals.

The “T”-output (open collector control output) terminals (no. 5 and 10) are triggered by a fire alarm on any address in the loop. Steady light in the LED until the BS-100 panel is reset.

**Alarm output
module BSB-100**
3.2 External connections to optional alarm output module BSB-100

The module features 4 optional outputs (bells, buzzers, sounders, alarm lights). All alarm outputs (AK-1 to AK-4) are freely programmable.

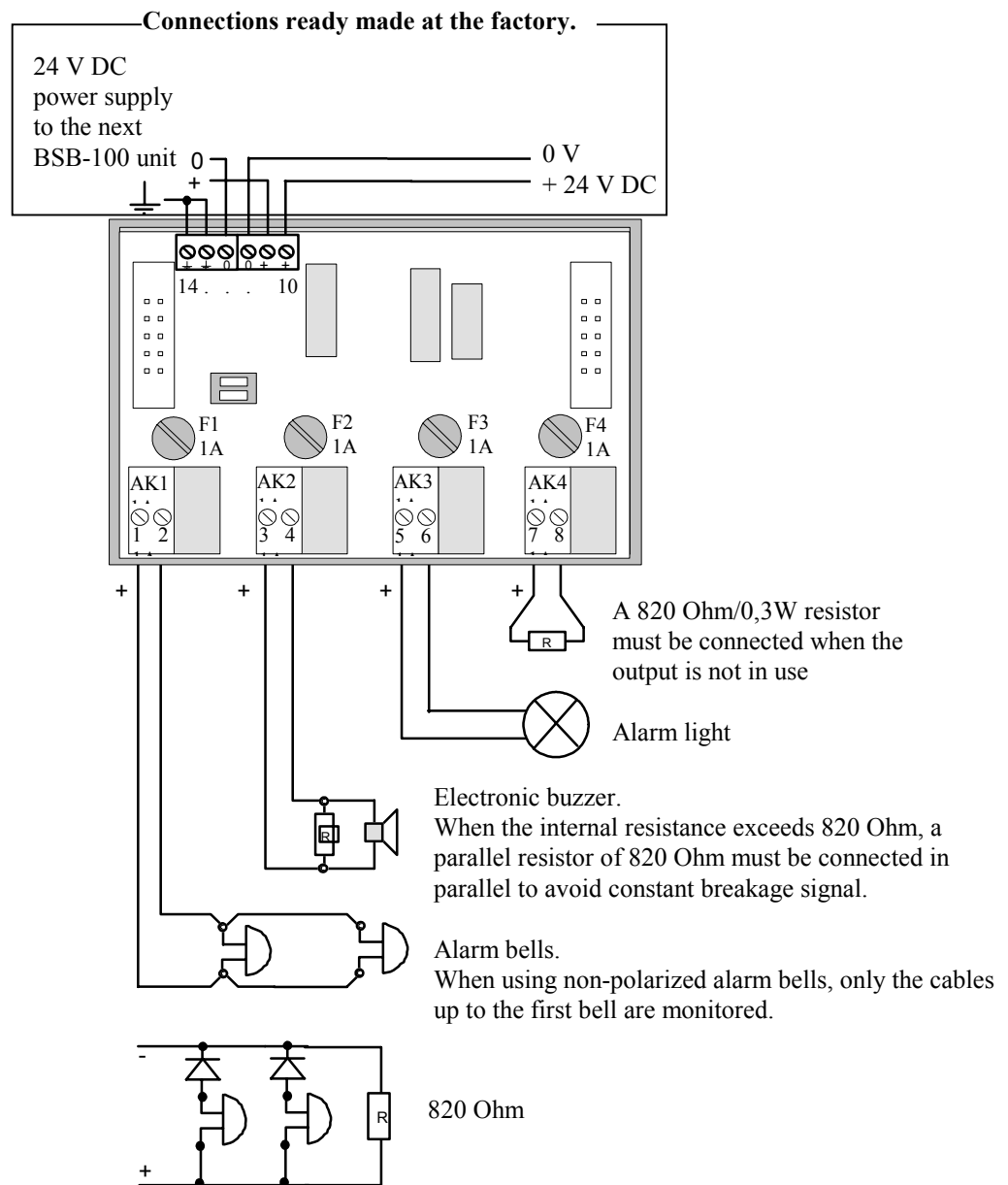

When an alarm circuit with polarized bells are used, a 820 Ohm resistor must be connected in parallel to the last bell on the circuit as indicated in the fig.

Fig. no. 13: Example of external connections on BSB-100

All alarm outputs (AK1 to AK4) are relay outputs:
Max. load 1 A at 24 V DC. (For Chinese marked 0,25A).

**Control output
module BSJ-100**
**3.3 External connections to optional control output module
BSJ-100 / BSJ-101**

The module features 16 control outputs. All outputs are freely programmable.

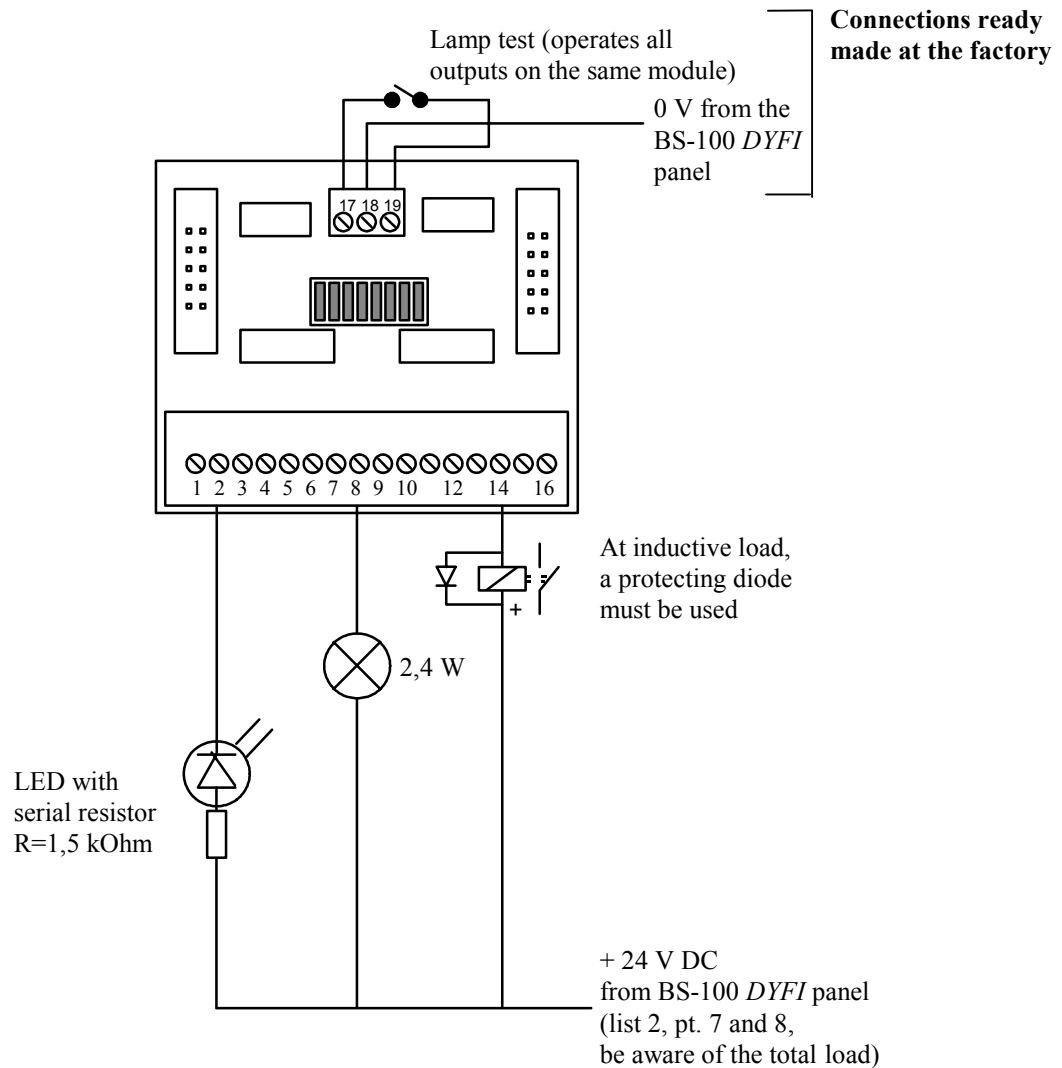

Fig. no. 14: Example of external connections on BSJ-100/BSJ-101.

All outputs: Max. load 100 mA, open collector (NPN).



The control output modules BSJ-100 are used for up to 128 outputs. If more outputs are needed, the control output modules BSJ-101 must be used. (BSJ-101 from output 129-240)

Control output module BSL-100

3.4 External connections to optional data output module BSL-100

The module features both “20 mA current loop” and “RS232C” data outputs.

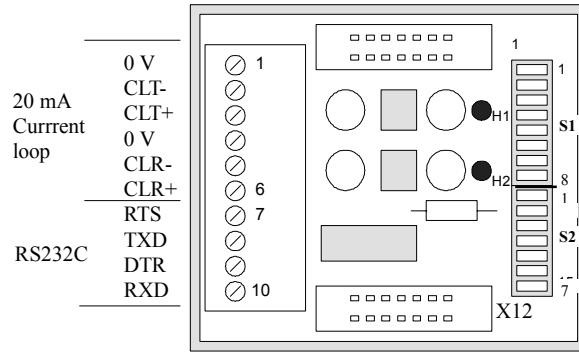

Fig. no. 15: External connections to data output module BSL-100

The mostly used connection configurations for BSL-100 and the corresponding peripheral equipment are shown below:



3.4.1 Connection of peripheral data equipment to the BSL-100 module

Data output: 20 mA current loop.

Max. cable capacitance: 220 nF (at 1200 baud)
 Max. cable resistance : 340 Ω.

Configuration A (on BSL-100): Active transmitter - Active receiver

Config.: A

Data output module BSL-100:
 Active transmitter,
 active receiver

Peripheral data equipment:
 (Passive transmitter,
 passive receiver)

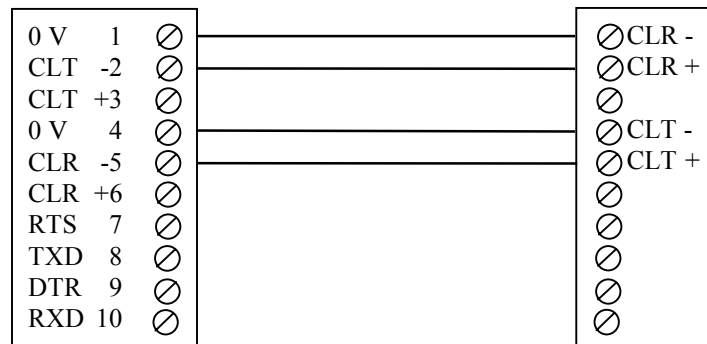

Fig. no. 16: Active transmitter - active receiver

Config.: B

Configuration B (on BSL-100): Active transmitter - Passive receiver

**Data output module
BSL-100:**
Active transmitter,
passive receiver

**Peripheral data
equipment:**
(Active transmitter,
passive receiver)

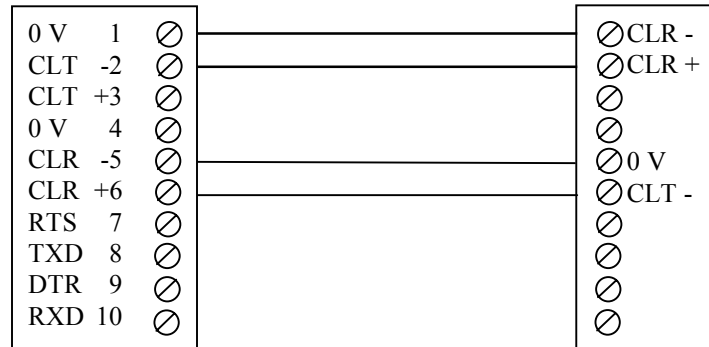

Fig. no. 17: Active transmitter - passive receiver

Config.: C

Configuration C (on BSL-100): Passive transmitter - Passive receiver

**Data output module
BSL-100:**
Passive transmitter,
passive receiver

**Peripheral data
equipment:**
(Active transmitter,
active receiver)

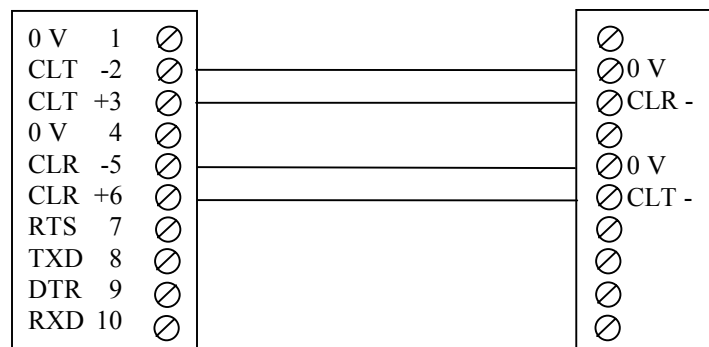

Fig. no. 18: Passive transmitter - passive receiver

**Autronica
peripheral
equipment
connected to
BSL-100**

3.4.2 Table of connections between data output module BSL-100 and Autronica manufactured peripheral equipment

Autronica peripheral equipment type:	Connection between BSL-100 and peripheral equipment:	Max. loop resistance (Ohm):
BU-100 Fireman's panel	Configuration type A	1 pc. 690 5 pcs. 450 10 pcs. 150
BU-101 (marine vers.) Fireman's panel	Configuration type A	1 pc. 690 5 pcs. 450 10 pcs. 150
BU-70 Indication panel	Configuration type A	1 pc. 690 5 pcs. 450 10 pcs. 150
KDL-26B Communication line splitter	Configuration type B	1 pc. 690
EA-2A Micro computer	Configuration type B	1 pc. 690 5 pcs. 450 10 pcs. 150
EA-3A Micro computer	Configuration type B	1 pc. 690 5 pcs. 450 10 pcs. 150
AutroMaster 300 Alarm presentation system	Connected via driver unit RTZ-20 (contact Autronica)	-----
AutroMaster 5000 Alarm presentation system	Connected via driver unit RTZ-20 (contact Autronica)	-----

Please be aware of the information given in section 3.4.1 concerning max. cable capacitance.

For configuration of other types of peripheral equipment, please contact Autronica.

“Configuration types”: See section 3.4.1.

Autronica Fire and Security AS is an international company, based in Trondheim, Norway and has a world-wide sales and service network. For more than 40 years Autronica's monitoring systems have been saving lives and preventing catastrophes on land and at sea. Autronica Fire and Security's most important business area is fire detection & security. Autronica Fire and Security stands for preservation of environment, life and property.

Quality Assurance

Stringent control throughout Autronica Fire and Security assures the excellence of our products and services. Our quality system conforms to the Quality System Standard NS-EN ISO 9001, and is valid for the following product and service ranges: marketing, sales, design, development, manufacturing, installation and servicing of:

- fire alarm and security systems
- petrochemical, oil and gas instrumentation systems for monitoring and control

In the interest of product improvement, Autronica Fire and Security reserves the right to alter specifications according to current rules and regulations.

Autronica Fire and Security AS

Fire and Security, Trondheim, Norway. Phone: + 47 73 58 25 00, fax: + 47 73 58 25 01.

Oil & Gas, Stavanger, Norway. Phone: + 47 51 84 09 00, fax: + 47 51 84 09 99.

Autronica Industrial Ltd., Watford, United Kingdom. Phone: 1923 23 37 68, fax: 1923 22 55 77.