



Alarmline II Analogue

Linear Heat Detection Cable and Controller

Installation Instructions

Contents:

Alarmline II Analogue Linear Heat Detection Quick Installation Instructions	Page 3
Important Guidelines	Page 4
Introduction	Page 5
Features	
Technical Data	
Technical Specifications	Page 6
Electrical Specifications	
Environmental Specifications	
Mechanical Specifications	
Typical System Configurations	Page 7
Conventional Fire Alarm Systems	
Addressable Fire Alarm Systems	
Analogue Heat Detector	
Installation Specifications	Page 8
Leader Cable	
Detection Cable	
Installation Hardware	Page 9
Low Temperature Installation Considerations	Page 9
Splicing	Page 10
Testing and Verification	Page 10
Chemical Resistance Chart	Page 10
Mounting Instructions	Page 11
Control Module Wiring	Page 11
Programmable Control Module	Page 12
Hazardous Area Setup	Page 12
Control Module Setup (laptop)	Page 12-13
Control Module Setup (self-programming module)	Page 14
Alarm/Pre-Alarm Temperatures	Page 15
(Pre)Alarm Condition	Page 15
Remote Reset	Page 15
Alarmline II Analogue Linear Heat Detection product range	Page 16

Alarmline II Analogue Linear Heat Detection Quick Installation Instructions

1. Install cable into desired area. Pull the cable of the reel using a reel stand. Ensure the cable is correctly mounted.
2. Strip the cable at both ends. Peel the foil back. A foil shield wire should be present which allows the foil to be grounded. This should be cut back at the end of line module end.
3. Open the End of Line (EOL) module.
4. Connect the wires as per the description on the EOL PCB. Ensure the cores are secured in the connector. **DO NOT OVERTIGHTEN.**
5. Close up the EOL module and screw the lid down.
6. At the Alarmline II Analogue controller end, using a multimeter or ohmmeter, measure the resistance between a clear core and the red or white cores. Measuring using one clear core should show a resistance of 30M or greater. Measuring using the other clear core should give a resistance between the ranges shown below.
7. Once the cores have been identified write down the resistance between the clear core and the white wire. **This is the Calibration Resistance.**
8. Cut the white core back at the controller end and connect the remaining cores to the Alarmline II Analogue controller.

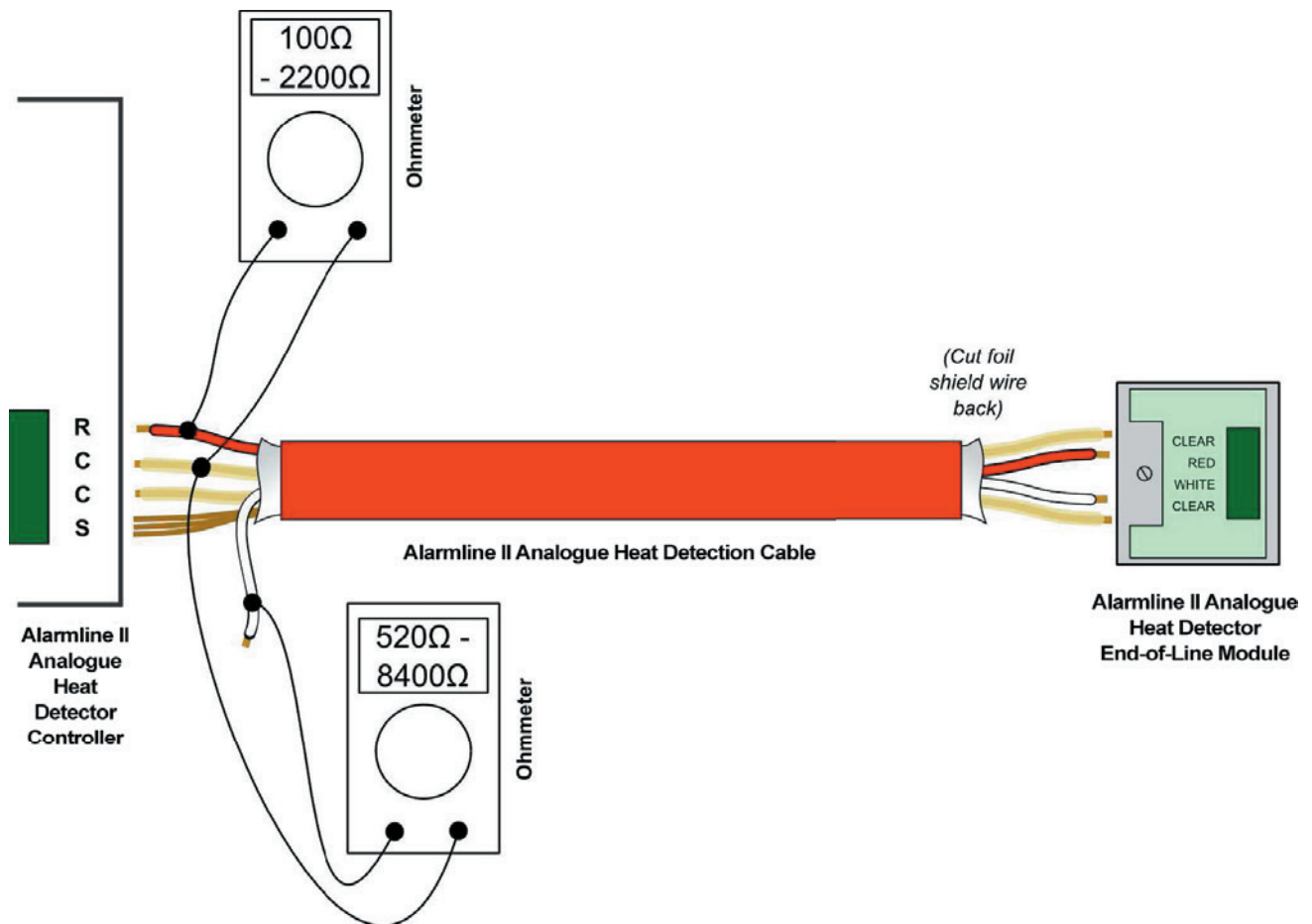







Important Guidelines

Please read this instruction leaflet thoroughly before commencing installation.

Install the linear heat detection cable accordingly to meet local and country installation requirements.

Alarmline II Analogue linear heat detection cable must be installed in accordance with NFPA 70 & 72, NEC 760 (National Electric Code) and Authorities Having Jurisdiction.

- ✓ Support the detection cable at 1m (3ft) to 1.5m (5ft) intervals.
- ✓ Test the detection cable before installation using a multimeter.
- ✓ Ensure the maximum **ambient** temperature rating of the detection cable will not be exceeded during storage or normal operating conditions (-40°C to +90°C).
- ✓ Ensure the detection cable is spaced at less than or equal to the maximum approved spacing.
- ✓ Ensure the detection cable is not in contact with any material which may conduct heat onto the cable directly. A neoprene insulator or equivalent should be placed between the fixing clip and heat sensing cable.
- ✓ Ensure any cable glands used are tightened to form a secure and moisture proof seal around the detection cable.

-  Avoid allowing the detection cable to come in contact with any material which acts as a heat sink. This may delay the activation of the cable in alarm situations.
-  Do not connect lengths of Alarmline II Analogue Linear Heat Detection cable in 'T' connections or spurs.
-  Do not paint the detection cable.
-  Do not place the detection cable under excessive tension.
-  Do not bend the detection cable at right angles. The minimum bend radius is 2" or 50mm.
-  Avoid subjecting the detection cable to mechanical damage which could result in false activation.
-  Avoid laying the detection cable in areas where heavy traffic may result in the cable being crushed.

Introduction

Alarmline II Analogue Linear Heat Detection Cable and Controller provide an easy installation method for sensing changes in temperature. The analogue technology offers separate Pre-Alarm and Alarm outputs in order to maximise functionality, coupled with open and short circuit detection and discrimination. Ambient temperature compensation maintains alarm temperature accuracy. The technology offers alternative over heat protection in a vast range of applications and industries, from power generation to oil and gas industries.

Using a zone or switch monitor, the analogue linear heat detection system can easily be interfaced to an addressable loop or can be directly connected to a zone of any conventional fire panel.

The analogue technology comprises of a four core sensing cable and a separate interface unit. This unit monitors the resistance of temperature sensitive polymers within the sensor cable. An abnormal change in resistance, due to an overheat condition, along the analogue detection cable triggers either a Pre-Alarm or Alarm on the interface unit.

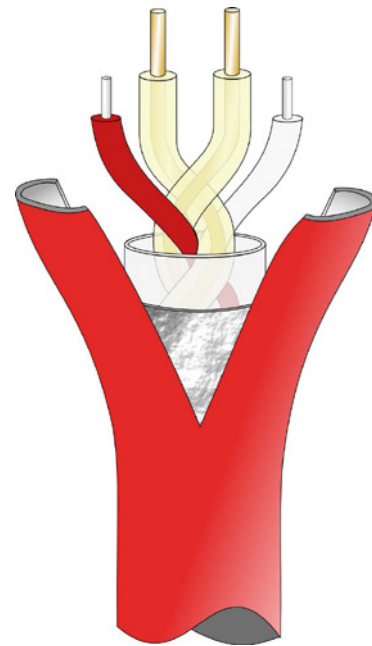

Figure 1: Alarmline II Analogue Linear Heat Detection Cable Construction

Features

- Full UL 521 Approved (UQGS Category Code)
- CE Marked
- Temperature range 54°C (129°F) – 105°C (221°F)
- Extensive coverage of up to 500 metres (1640ft) in one continuous length
- Standalone or laptop programmable interface (no nomogram interpretation)
- Separate Pre-Alarm and Alarm outputs
- Alarm triggered if interface internal temperature exceeds 100°C (212°F)
- Optional Nylon coating offering UV protection and increased durability for outdoor use
- Optional Polypropylene coating for caustic environments

Technical Data

Cable

Construction:	Overall insulated, 4-core cable
Insulation:	1kV tested protective outer coat
Additional Insulation Options:	Nylon, Polypropylene or Stainless Steel Braid
Approvals:	UL Approved, CE Marked, RoHS Compliant
Zone Length:	30m (100ft) to 500m (1640ft)
Wire Overall Diameter:	4.50mm to 6.05mm (0.180" to 0.238")
Minimum bend radius:	50 mm (2")
Ambient Temperature Range: (dependant upon action temperature)	-40°C – +90°C (40°F – +194°F)

Controller

Operating Voltage Range:	20Vdc – 30Vdc
Relay outputs:	Alarm & Pre-alarm FORM C 2A @ 30Vdc - resistive 0.25A @ 250Vac (62.5VA) - resistive Fault output Opto-isolated phototransistor output: Max 50V @ 20mA
Dimension:	W182mm x H180mm x D90mm (W 7 1/8" x H7 1/8" x D3 1/2")
Enclosure Rating:	IP65 (IK08) polycarbonate with removable cover

Technical Specifications

Electrical Specifications

Operating Voltage Range	20Vdc - 30Vdc
<i>Current Consumption</i>	
...normal & fault conditions	Self-Programmable version <70mA Laptop-Programmable version <40mA
...pre-alarm OR alarm conditions	<80mA
...pre-alarm & alarm conditions	<100mA
Relay outputs	Alarm & Pre-alarm FORM C 2A @ 30Vdc load rating - resistive 0.25A @ 250Vac (62.5VA) load rating - resistive
Fault output	Opto-isolated phototransistor output Max 50V @ 20mA
Remote Reset	Isolated input for resetting module remotely 20-28Vdc pulse for >5s)

Mechanical Specifications

Material

...Controller	Polycarbonate
...Sensor Cable	Overall insulated, quad core twisted & foil shield

Colour

...Controller	Light Grey
...Sensor Cable	Red
...with Nylon coating	Black
...with Polypropylene coating	Transparent
...with Stainless Steel Braid	Silver

Maximum Zone Length	500m (1640ft)
Minimum Zone Length	30m (100ft)
Dimensions (Controller)	W182mm x H180mm x D90mm (W 7 1/8" x H7 1/8" x D3 1/2")
Enclosure Rating	IP65 (IK08) polycarbonate with removable cover)

Environmental Specifications

Min/Max Operating ambient temperature

...Controller	0°C – +50°C
...Sensor Cable (recoverable)	-40°C – +125°C

Continuous operating temperature range

...Sensor Cable	-40°C – +90°C
-----------------	---------------

Humidity

...Controller	0% - 95% RH (Max. 75% RH for <75m cable and 54°C alarm setpoint)
...Sensor cable	0% - 99% RH

Weight

Controller	804g
...Self-Programmable version	810g
...Laptop-Programmable version	720g

Sensor Cable

PVC coating	23.7g per m
...with additional Polypropylene coating	30.4g per m
...with additional Nylon coating	31.9g per m
...with additional Stainless Steel Braid	33.0g per m
...with additional Nylon & SS Braid	41.7g per m

Sensor Cable Diameter

PVC coating	4.57mm +/- 0.075mm (0.180" +/- 0.003")
...with additional Polypropylene coating	5.50mm +/- 0.075mm (0.217" +/- 0.003")
...with additional Nylon coating	5.50mm +/- 0.075mm (0.217" +/- 0.003")
...with additional Stainless Steel Braid	5.10mm +/- 0.075mm (0.200" +/- 0.003")
...with additional Nylon & SS Braid	6.05mm +/- 0.075mm (0.238" +/- 0.003")

Typical System Configurations

Conventional Fire Alarm Systems

Alarmline II Analogue Linear Heat Detection (LHD) cable should be connected to the initiating device circuit on a conventional fire alarm control panel. Leader cable may be used between the interface unit and the fire alarm control panel if the area requiring protection is some distance away from the control panel.

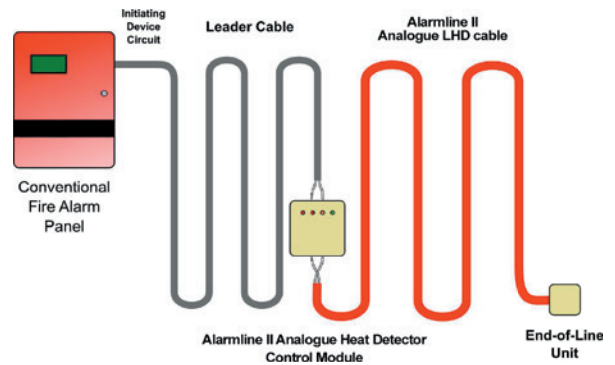

Figure 1: Typical Wiring Configuration Conventional System

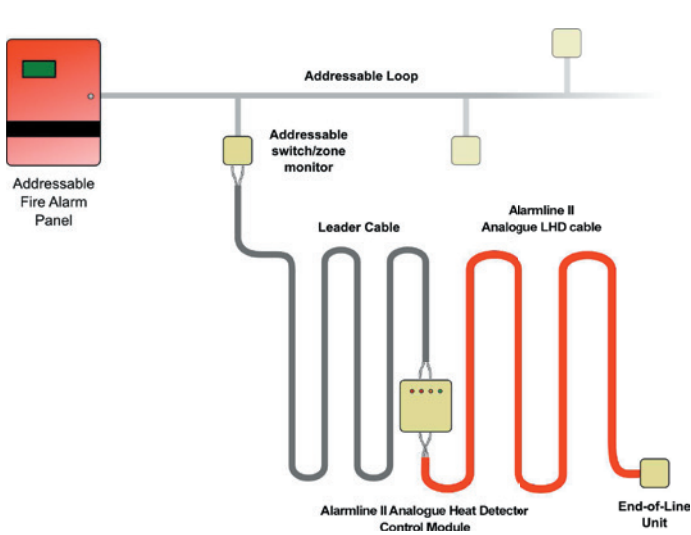

Figure 2: Typical Wiring Configuration Addressable System

Addressable Fire Alarm Systems

When used as part of an addressable system, Alarmline II Analogue LHD cable should be connected onto the addressable loop using a switch or zone monitor. Leader cable may be used between the interface unit and the addressable switch or zone monitor if the area requiring protection is some distance away.

Analogue Heat Detector

The Alarmline II Analogue Heat Detector control module and sensor cable should be connected to the initiating zones of a fire alarm control panel and powered from a UL listed power supply. A typical wiring configuration is shown opposite:

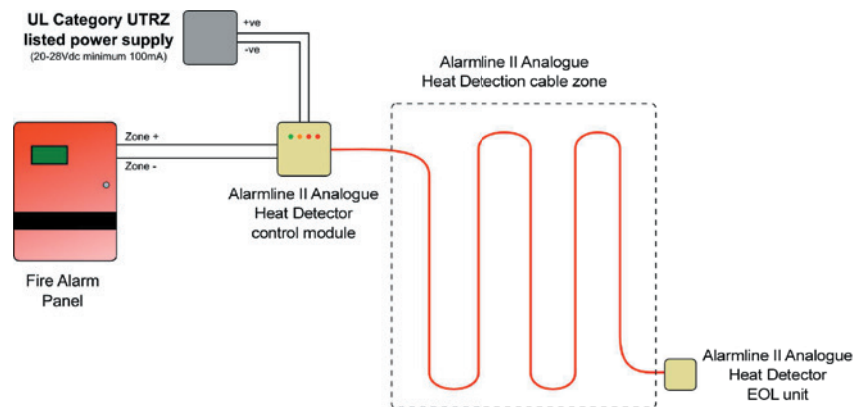

Illustration 2: Typical wiring configuration of Alarmline II Analogue Heat Detector

Installation Specifications

Leader Cable

Alarmline II Analogue Leader cable should be used between the fire alarm control panel or addressable switch/zone monitor and the Linear Heat Detection cable. Do not use generic Leader cable as this can interfere with the correct operation of the controller. A secure waterproof (IP65+) junction box must be used to connect the leader cable to the detection cable.

The maximum length of leader cable between the Alarmline II Analogue controller and start of Alarmline II Analogue LHD cable is 250m.

Detection Cable

A very important factor in determining which action temperature of analogue linear heat detection (LHD) cable to use is the maximum ambient temperature the cable will be exposed to. To provide the fastest alarm response but lowest possibility for false alarms the lowest action temperature above the maximum ambient temperature should be chosen. For example, if the maximum ambient temperature is determined to be 55°C (131°F), an action temperature of 86°C (186.8°F) should be chosen (if the fastest possible response time is required).

Maximum Ambient Temperature	Available Action Temperatures
Up to 30°C (68°F)	54°C (129.2°F) ¹
Up to 47°C (113°F)	64°C (147.2°F), 71°C (159.8°F) Prealarm, 72°C (161.6°F) Alarm, 79°C (174.2°F)
Up to 69°C (158°F)	86°C (186.8°F) Alarm, 93°C (199.4°F) Prealarm, 100°C (212°F) Alarm

*Table 1: Maximum Ambient temperature for action temperature
(in accordance with NFPA 72 5.6.2.1.1)*

¹ NOTE: 54°C alarm or prealarm setting is for use in controlled ambient areas only. Specifically when the overall sensor cable length is less than 75m (246ft) ensure the humidity and temperature of the controller DO NOT exceed 75% and 30°C respectively.

Installation Hardware

There are many applications which Linear Heat Detection cable is used to provide protection for.

The linear heat detection cable should be adequately supported to prevent sagging. Ideally cable supports should be placed every 1m (3ft) and no more than 1.5m (5ft) apart. It may be necessary to place more supports around corners and other transition areas.

Care should be taken when mounting the cable in clips (or equivalent) that they are not done so tight as to crush the cable. The detection cable should be held firmly without deformation. Avoid placing excessive tension in the cable, no greater than 50N. Ensure also that the minimum bend radius is observed at all times – 50mm (2").

It is of particular importance to use a silicone pad insulator between the heat sensing cable and the fixing clip if the metal clip is exposed to the sun or attached to a piece of equipment which may get hot and transfer the heat to the cable.

Where possible, it is preferable to install the linear heat detection cable in one continuous run of cable with as few splices as possible.

When pulling the detection cable from a reel, a reel stand must be used. Do not pull the cable off the reel vertically with the reel stationary as this will twist and damage the cable. A guide wire may be required for

installations where supporting the cable at the recommended spacing is not practical. Ensure the diameter or gauge of the guide wire is adequate for the distance which is being spanned. Commercially available stainless steel wire with a diameter of approximately 2mm is suitable for use as a guide wire.

Connections into junction boxes and other enclosures must use strain relief connectors which provide dust and moisture protection (IP65 or greater protection). The standard diameter of detection cable is 4.5mm (0.177") to 6.05mm (0.238") Suitable cable glands are shown below which fit an M16 standard knockout.



Figure 4: Typical Cable Glands for connection of Linear Heat Detection cable into an enclosure

Low Temperature Installation Considerations

Alarmline II Analogue Linear Heat Detection cable is suitable for use in ambients down to -40°C (-40°F). Such conditions occur in cold storage freezer warehouses and outdoors for example.

When installing LHD cable in low ambients or for use in low temperature conditions careful consideration of the conditions and environment should be undertaken.

If possible, do not install the LHD cable when the ambient temperature is below -10°C (-14°F). The materials within the cable will become less flexible and are more prone to damage. If the ambient temperature is likely to drop significantly after installing the cable take into account linear shrinkage of the cable when attaching support brackets. The cable can shrink in length by 12% at -40°C (-40°F).

A silicone pad insulator should be placed around the cable before clipping into the support bracket. This prevents damage to the cable and reduces the heat sink effect of the clip.

The minimum bend radius of the detection cable should be increased to 100mm (4") to account for the reduced flexibility. The maximum distance between support brackets should be no more than 1m (3ft) and it is important to support the cable close to either side of any bend.

Ensure any junction boxes other enclosures are waterproof and suitable for the expected operating temperatures.

Splicing

If the analogue Linear Heat Detection cable gets damaged or has exceeded the maximum restorable temperature of 125°C (257°F), the section can be removed and a new section spliced in its place.

Care should be taken during splicing to ensure the core conductors do not come into contact with each other at any point and the final spliced joint is secure and made waterproof. A junction box must be used to connect the newly installed sensor cable to the existing sensor cable.



When replacing a section of the detection cable for any reason, the section including at least 3m (10ft) either side of the damaged area should be replaced.

Testing and Verification

Routine maintenance and checking should be carried out to ensure the Linear Heat Detection cable will function as expected and has not been damaged etc.

A visual inspection should be performed to ensure all support brackets and other aspects of the physical installation are suitable. The cable should also be visual checked for damage to the outer or inner insulation. Check to make sure the silicone pads are correctly installed around the cable in the clips.

Any joints which have been made should be checked to make sure they are secure and any junction boxes should be checked to ensure they are correctly installed.

Electrical tests should be carried out to determine the circuit created by the conductors is working. Remove the conductors from the interface unit and place a shorting wire between the two clear cores in the EOL unit leaving the other cores connected as normal in the EOL of unit. The resistance at the end just disconnected from the interface unit between the respective conductors should be as follows:

Measuring Points	Approx Ohms/m
Red <> Clear	3.5
Clear <> Clear	0.2
White <> Clear	16.9

To test in circuit with a fire alarm control panel or addressable switch monitor reattach the LHD cable to the interface unit. Disconnecting the red core or either clear core from the endofline device should put the system into fault. Placing a 1MΩ resistor across the two clear cores from the EOL unit should put the system into alarm.

Functional testing

Analogue Linear Heat Detection Cable is restorable up to 125°C (257°F) and therefore can be functionally tested to ensure it is working correctly.

For functional testing the system should be set to the lowest action temperature given the ambient conditions at the time of testing. Using a suitable device heat between 0.5% and 2% of detection cable up to a maximum of 125°C (257°F). Once the action temperature (including any tolerances) has been reached the system should alarm. Dipping the section of detection cable in recently boiled water is one method for testing the cable but ensuring that the maximum temperature is not exceeded.

Ensure the action temperature is reset to the required value before placing the system back into normal operation.

Chemical Resistance Chart

Chemical	PVC	Nylon	Polypropylene
Ammonia, Liquid	●●●●●	●●●	●●●●●
Butane	●●●●●	●●●●●	●
Copper Nitrate	●●●●●	●	●●●●●
Fuel Oils	●●●●●	●●●●●	●●●
Gasoline	●●	●●●●●	●●
Hydrofluoric Acid	●	●	●●●●●
Kerosene	●●●●●	●●●●●	●
Diesel Fuel	●●●●●	●●●●●	●●●●
Acetic Acid	●●	●	●●●●●

Mounting Instructions

The Alarmline II Analogue Heat Detector control module should be wall-mounted (or equivalent) using four screws in each corner of the base of the enclosure. The fixing dimensions are shown in figure 1.

Sensor Cable	
Minimum screw length	20mm
Maximum thread diameter	4.5mm
Maximum head diameter	7mm

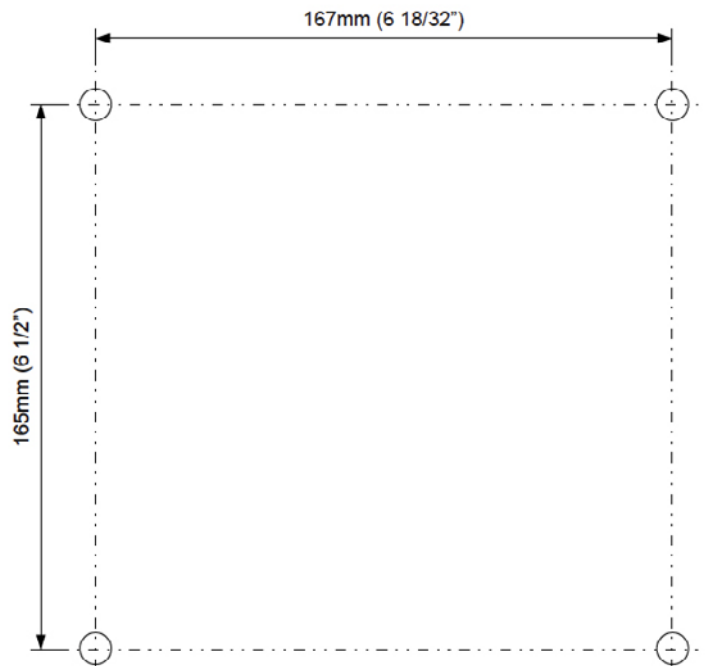

Figure 1: Fixing Dimensions for mounting Alarmline II Analogue Heat Detector Controller

Control Module Wiring

The Alarmline II Analogue Heat Detector control module is designed to be connected to any standard fire alarm control panel or addressable monitor module. It is intended to be powered via the 24Vdc switched power output which is interrupted when the control panel is reset. Figure 2 shows the typical connections to the PCB.

Remote Reset

The remote reset function allows the Alarmline II Analogue Heat Detector controller to be reset from a remote point. In order to trigger a reset supply 20-28Vdc (approx 10mA) for at least 5s to the remote reset input.

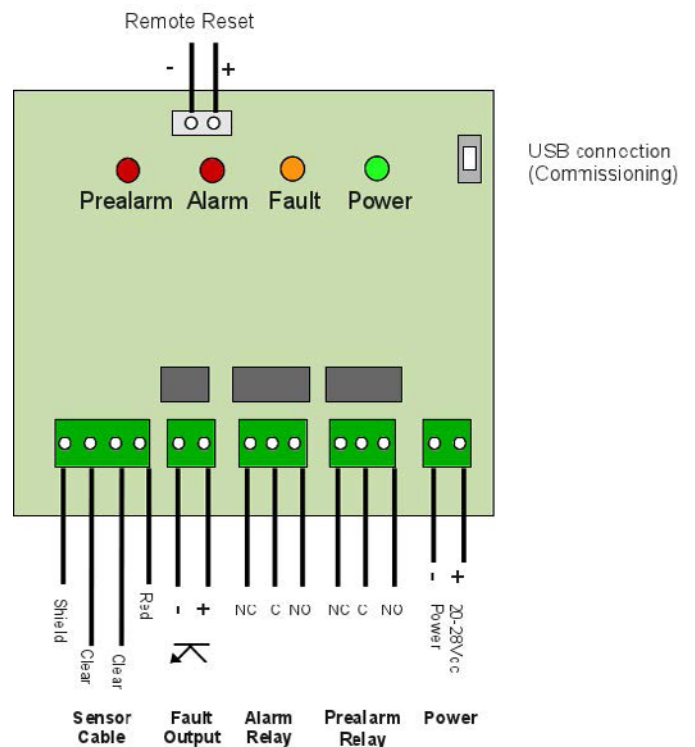

Figure 2: PCB Wiring Diagram

Programmable Control Module

The control module allows for on-site adjustment of response sensitivity to allow the sensor cable to be suited to the local environmental conditions. This **MUST** be done to commission the system and should

therefore be performed immediately after system installation.

The control module will output a fault signal until programming has been completed.

Hazardous Area Setup

For installations in hazardous areas please refer to the Alarmline II Analogue Hazardous Area Installation Instructions to correctly commission the Alarmline II Analogue controller.

Control Module Setup (laptop)

If no self-programming module is installed (see page 11) the Alarmline II Analogue Heat Detector control module must be programmed using a laptop computer. To commission the control module first ensure the minimum connections have been connected to the unit (see Control Module Wiring page 11). Follow the steps below to commission Alarmline II Analogue Heat Detector:

1. Install and run the commissioning software before connecting the control module to the laptop. The software is supplied on a CD or USB key with the Alarmline II Analogue Heat Detector control module. Alternatively the software can be downloaded by going to <http://dl.thermocable.com/ProReact>
2. Power up the Alarmline II Analogue Heat Detector control module.
3. Go to File->Connect or click the green connect icon.
4. At this point, connect the control module to the laptop via the USB cable and turn the control module on.
5. After powering up the control module, click the "Get Port List" button.
6. The selected COM port should be the controller. Click the "Connect button" then click "Ok".
7. Enter the calibration resistance (see Quick Installation Instructions for wiring).
8. **Check the Calculated zone length matches the installed sensor cable length.**
9. Select alarm/pre-alarm temperature(s).
10. Select pre-alarm enabled with the checkbox.
11. Click "Update Settings" to upload settings – the status bar at the bottom of the screen shows the current status of the Alarmline II Analogue Heat Detector controller.
12. Click "Get Current Settings" to download the settings from the control module to the laptop. This is useful to check which settings are currently loading on a particular module.
13. To save these settings go to File -> Save Configuration. This will save a file with the necessary settings (calibration resistance etc) to re-commission the module.
14. Click "Erase Settings" to wipe the settings on the control module.
Warning: Do not leave the control module operating after erasing the settings. NO ALARM OR PREALARM WILL TRIGGER. The control module will trigger the fault output and light the fault indicator.
15. Click the "Update" button in the diagnostics frame to display diagnostic information from the control module. This should only be carried out by trained service personnel.
16. **If the ambient temperature in the vicinity of the sensor cable is greater than 0 deg C then it is important to ensure that the "PTC Temp" field in the diagnostics frame closely matches the ambient temperature around the cable (within $\pm 2.5^{\circ}\text{C}$ / $\pm 4.5^{\circ}\text{F}$). If the "PTC Temp" value is outside this tolerance re-measure the calibration resistance and return to step 7. If the calibration resistance is the same as previous, add or subtract 0.017 kohms to the value and repeat from step 7.**

Control Module Setup (laptop)

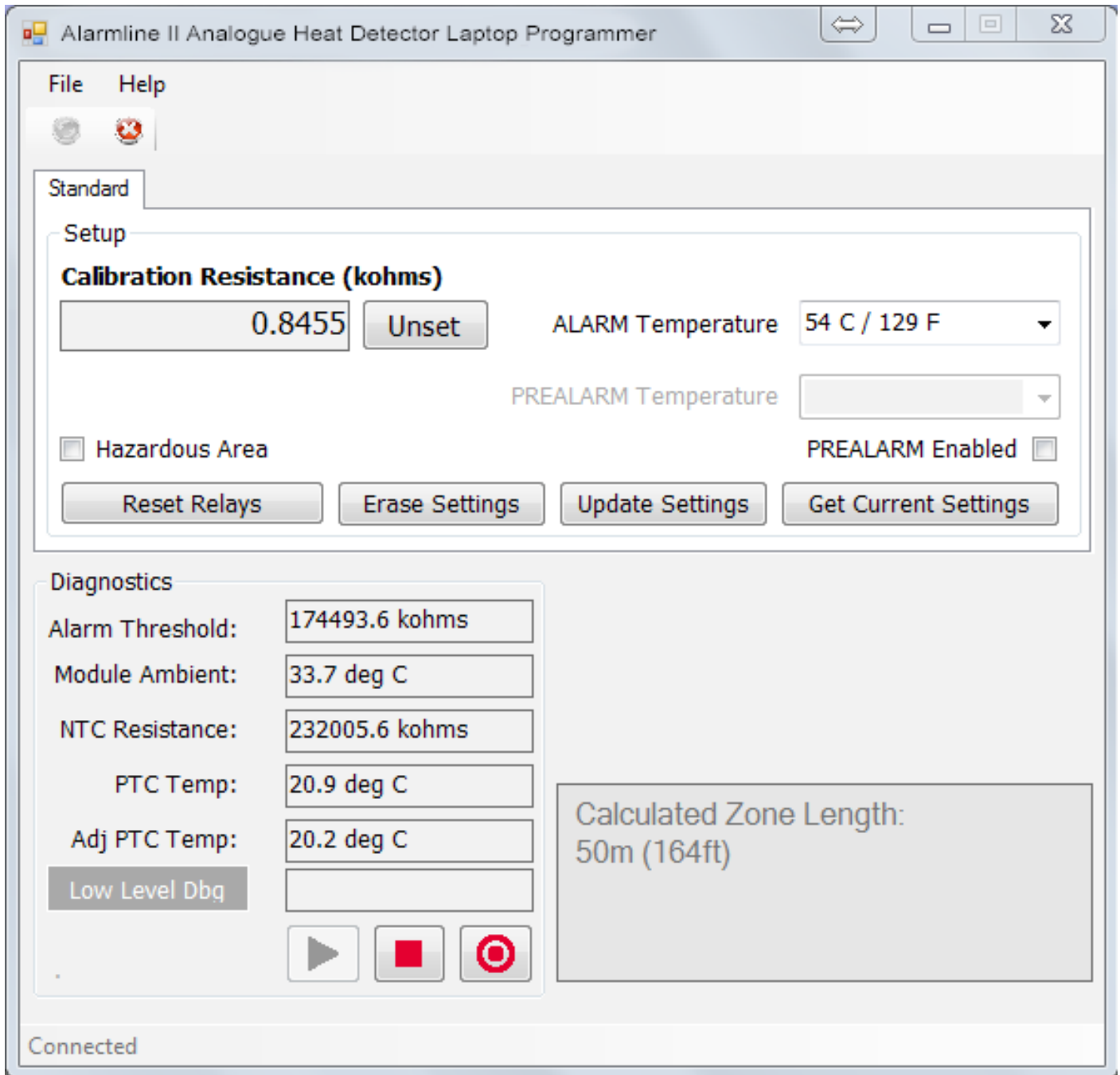
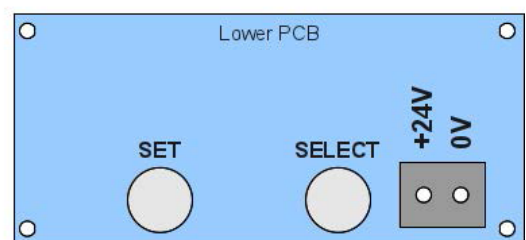
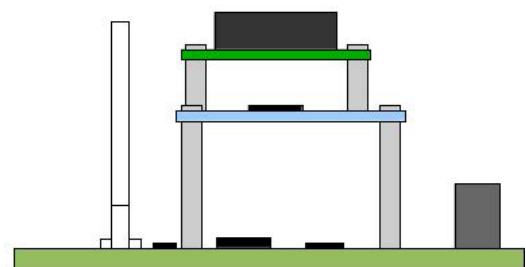
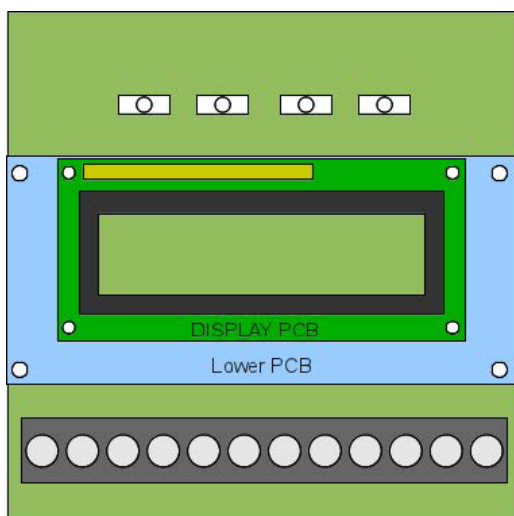

Figure 3: Alarmline II Analogue Heat Detector Laptop Programming Software

Control Module Setup (Self-Programming Module)

If the self-programming module is installed, the Alarmline II Analogue Heat Detector control module can be installed without the use of a laptop computer. Once the necessary connections have been made to the PCB (see "Installation - control module wiring" page 7) the system should be powered on. Follow the instructions on the LCD display, selecting the ALARM and PREALARM temperatures as required to program the unit. **Connect the supplied USB cable between the programming module and BASE PCB when asked to do so on the display.**

1. Select which mode is required on the self-programming module by pressing the SELECT button. This will cycle through "Erase Settings", "Diagnostics" (points 10-12), "Commission" (points 2-11) and "Get Settings" (points 13).
2. Enter the calibration resistance on the display. Press SELECT to cycle through numbers and press SET once the correct number has been chosen. The calibration resistance is measured in kilo-ohms. Enter the first two numbers after the decimal point measured by the ohmmeter or multimeter (see quick installation instructions).
3. Once the calibration resistance is entered press SET to confirm.
4. The display will read the calculated zone length. If this matches with the installed sensor cable length press SELECT to change to "Yes" and press SET.
5. Select the desired alarm temperature by pressing the SELECT button. Once the alarm temperature is chosen press SET.
6. Select whether a pre-alarm value is required by pressing SELECT to change the display to "Yes". (See (Pre)Alarm Condition for detail of what pre-alarm temperatures are available).
7. If enabled, select the suitable pre-alarm temperature as per point 4 above.
8. When the display instructs you to connect the Alarmline II Analogue Heat Detector controller connect the USB cable between the self-programming module and the BASE control module. Then press SET.
9. The self-programming module will download the settings to the control module and display "Settings transferred ok" when done. Press SET to continue.
10. The self-programming will always automatically show diagnostic information once the control module has been commissioned. This is useful for trained service personnel when diagnosing a problem or confirmed the commissioning has been performed correctly.
11. **If the ambient temperature in the vicinity of the sensor cable is greater than 0 deg C then it is important to ensure that the temperature in the bottom left of the LCD during diagnostics closely matches the ambient temperature around the cable (within $\pm 2.5^{\circ}\text{C} / \pm 4.5^{\circ}\text{F}$). If the value is outside this tolerance re-measure the calibration resistance and return to step 2. If the calibration resistance is the same as previous, add or subtract 0.017 kohms to the value and repeat from step 2.**
12. In normal operation the USB cable should be removed. The display will then read "ProReact Normal Operation".
13. To return to the beginning once the diagnostic information is shown hold down the SET and SELECT buttons for several seconds.
14. If "Get Settings" has been selected, connect the USB cable to the control module and self programming module and press SET.
15. The display will show the current settings in the control module including the zone length, alarm and pre-alarm temperatures. These should be written down if they are to be required later.
16. Press SET again to return to the diagnostic information (see point 10).
17. If "Erase Settings" has been selected, connect the USB cable to the control module and self-programming and press SET.
18. The self-programming module will erase any commissioning information on the control module. **This will put the control module into a fault condition. Do not leave the control module operating in this situation. NO ALARM OR PRE-ALARM WILL TRIGGER.**



Power supply Input Polarity

Illustration 3: Alarmline II Analogue Heat Detector control module with programming module installed

Alarm/Pre-Alarm Temperatures

Alarmline II Analogue Heat Detector is designed such that when a section, equal to 3% in length of the overall sensor cable length, reaches a user-defined action temperature an alarm is triggered.

For example, for a 30m/100ft cable if a 64°C/147°F action temperature is chosen an alarm will be activated when 0.91m/3ft of the sensor cable reaches 64°C/174°F.

For a greater proportion of sensor cable subject to an abnormal temperature the activation temperature will be lower.

For a smaller proportion of sensor cable subject to an abnormal temperature the activation temperature will be greater.

Table 1 lists the activation temperatures when a 1%, 2%, 3% or 5% length of the sensor cable is subject to an overheat condition.

Temperature (deg C) for percentage length of sensor cable subject to overheat				
5%	3% (UL Tested)	2%	1%	
50	54	57	63	
60	64	68	74	
67	71	75	83	(Prealarm only)
68	72	76	84	(Alarm only)
74	79	84	95	
80	86	93	103	(Alarm only)
86	93	100	108	(Prealarm only)
93	100	106	113	

Table 1: Alarm/Pre-Alarm Temperatures for percentage length of sensor cable

(Pre)Alarm Condition

The Alarmline II Analogue Heat Detector control module continuously monitors the sensor cable for changes in resistance. During installation a response sensitivity was selected which programmed the control module to look for a specific threshold resistance.

If an overheat or fire condition arises along the cable length which matches the pre-selected temperatures an ALARM or PREALARM signal will be initiated by the control module. The corresponding indicator light will be lit and relay activated. Once the alarm condition has been cleared the unit can be reset remotely using the remote reset connections (see PCB drawing) or will reset automatically once the temperature drops below the alarm temperature.

The available Pre-Alarm temperature range is calculated once the alarm temperature has been selected either on the self-programming module or in the laptop software. In both cases the Pre-Alarm must be enabled to select a pre-alarm temperature. Table 2 shows the available prealarm temperatures for a given alarm temperature.

Selected Alarm Temperature	Available Pre-Alarm Temperature(s)
54°C / 129.2°F	NOT AVAILABLE
64°C / 147.2°F	54°C
72°C / 161.6°F	54°C, 64°C
79°C / 174.2°F	54°C, 64°C, 71°C
86°C / 186.8°F	54°C, 64°C, 71°C, 79°C
100°C / 212°F	54°C, 64°C, 71°C, 79°C, 93°C

Table 2: Available Pre-Alarm temperatures for selected Alarm Temperatures

Alarmline II Analogue Linear Heat Detection product range

Part No	Description	100m Reel		500m Reel	
		Weight	Dimms	Weight	Dimms
AA-xxxx	Alarmline II Analogue LHD cable – Red PVC	2.97	ø300mm x 100mm	14.38	ø430mm x 135mm
AAN-xxxx	Alarmline II Analogue LHD cable - Nylon	3.84		19.09	ø430mm x 250mm
AAP-xxxx	Alarmline II Analogue LHD cable – Polypropylene	3.69		18.34	
AASS-xxxx	Alarmline II Analogue LHD cable – Stainless steel – on PVC	3.95		19.64	
AASSN-xxxx	Alarmline II Analogue LHD cable – Nylon + Stainless steel	5.20	ø430mm x 135mm	26.00	

Part No	Description	Weight	Dimms
AACUSP	Alarmline II Analogue Control Unit - Self-Programmable inc EOL unit	900g	182mm x 180mm x 90mm
AACULP	Alarmline II Analogue Control Unit - Laptop-Programmable inc EOL unit	810g	182mm x 180mm x 90mm
AACU-EOL	Alarmline II Analogue End-of-line Unit (replacement)	90g	60mm x 80mm x 30mm

Product warnings and disclaimers

THESE PRODUCTS ARE INTENDED FOR SALE TO AND INSTALLATION BY QUALIFIED PROFESSIONALS. UTC FIRE & SECURITY CANNOT PROVIDE ANY ASSURANCE THAT ANY PERSON OR ENTITY BUYING ITS PRODUCTS, INCLUDING ANY "AUTHORIZED DEALER" OR "AUTHORIZED RESELLER", IS PROPERLY TRAINED OR EXPERIENCED TO CORRECTLY INSTALL FIRE AND SECURITY RELATED PRODUCTS.

For more information on warranty disclaimers and product safety information, please check <https://firesecurityproducts.com/policy/product-warning/> or scan the QR code:

