

Battery Cabinet UEA-313/1, UEA-313-2

Product Datasheet

Features

- For 24V sealed lead batteries
- Wall mounting
- Designed to meet EN 54 requirements and conforms to CE standards
- Complies with environmental conditions of IEC-721-3-3 class 3k5

Description/Application

The Battery Cabinet UEA-313 is intended for decentralized power distribution.

The Battery Cabinet is delivered in 2 variants;

- UEA-313/1 with batteries only
- UEA-313/2 with batteries plus a battery charger for maintaining the charging of the batteries.

The cabinet accommodates 2 batteries, providing a maximum of 24V / 12Ah (2x12V / 12Ah), plus the optional 27,3V / 1,2A battery charger.

The battery cabinet UEA-313/1 is delivered with battery cables, a connection block for the connection of cables and fuses.

The battery cabinet UEA-313/2 is also delivered with a 27,3V / 1,2A battery charger.

The internal charger provides temperature compensated charging and is approved according to EN 54 part 4 for use together with EN 54 approved fire detection systems.



It is recommended that the batteries are replaced every fourth year (depending on the temperature conditions). The batteries must be replaced with batteries of the same type.

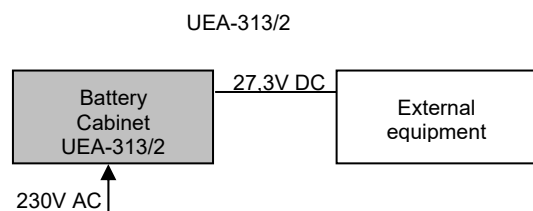
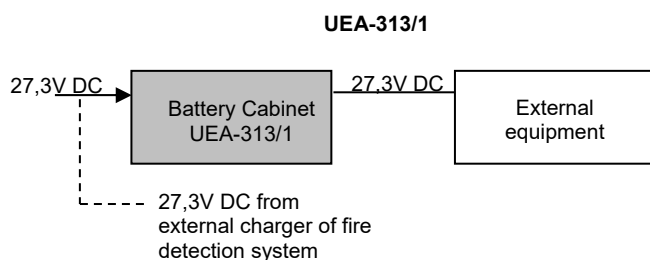

Technical specifications	
Dimensions (mm)	350x195x125 (wxhxd)
Weight (g)	UEA-313/1 (without battery) UEA-313/2 (without battery)
Materials	Steel cabinet, aluminium and moulded front in ABS
Mounting	Wall mounting
Protection Class	IEC-529 / IP30
Batteries	2 x 12V = 24V, 12Ah (not included)
Connections in UEA-313/1	External charger with 27,3V DC
Connections in UEA-313/2	230V AC
Connection out UEA-313/1 and UEA-313/2	27,3V DC (charging voltage)
Maximum power output	27W
Internal charger (UEA-313/2)	27,3V DC / 1,2A
Fuses:	
Output (last)	1,6A slow (5x20mm)
Mains charger	1,6A slow (5x20mm)
Connection blocks:	
Input	2,5 mm ²
Output	2,5 mm ²

Part number	Description
116-UEA-313/1	Battery Cabinet for 2 batteries 12V/12Ah
116-UEA-313/2	Battery Cabinet for 2 batteries and a 27,3V DC/1,2A charger

Dimensions (mm)

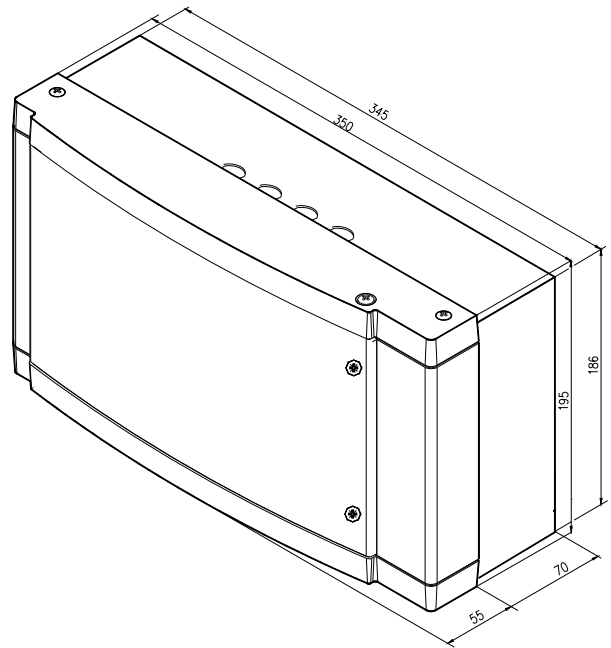

Connections

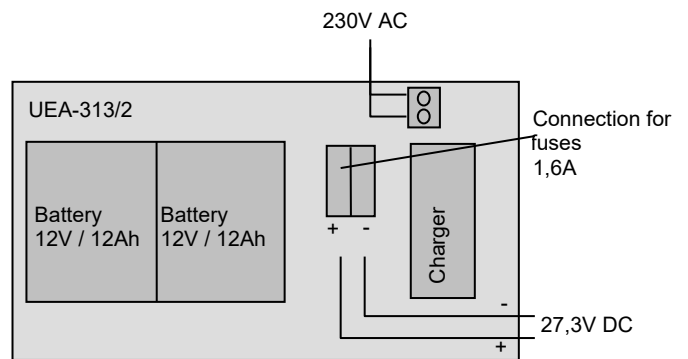
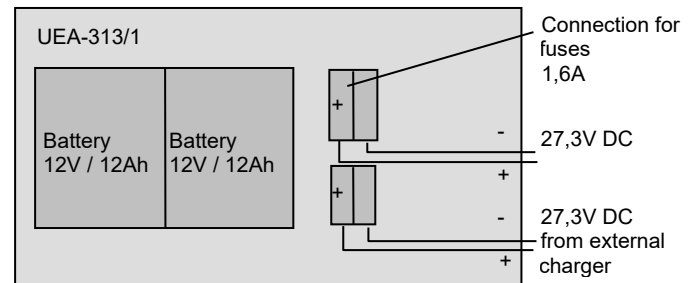

AUTRONICA FIRE AND SECURITY AS

Head office, Trondheim, Norway Tel: +47 73 58 25 00, fax: +47 73 58 25 01, e-mail: info@autronicafire.no
 Oil and Gas division, Stavanger, Norway Tel: +47 51 84 09 00, fax: +47 51 84 09 99
 Maritime division, Spikkestad, Norway Tel: +47 31 29 55 00, fax: +47 31 29 55 01