

Features

- Interfaces AutoSafe panels BS-310, BS-320 or BC-320 to the AUTROFIELDBUS
- Short circuit detection/isolation technology.
- Rail mounted.
- Conforms to CE standards.
- Tested according to EN-54 and IACS E10 requirements

Application / Description

The AUTROFIELDBUS driver EAU-341 is a communication protocol converter between the AutoSafe IFG panel and the BSD-340 PowerLoop drivers and BSD-321 protocol converters. The EAU- 341 provides a redundant field bus system with a ring loop topology.

The AutoSafe panels can have one AUTROFIELDBUS connected, and each AUTROFIELDBUS can host up to 31 bus units.

The AUTROFIELDBUS has short-circuit detection/isolation technology which ensures that only one AUTROFIELDBUS bus unit will be lost in case of internal failure (short-circuit). The ring loop topology ensures that no detectors/field units will be lost due to a single break or short circuit of the AUTROFIELDBUS cable. Furthermore, the EAU-341 provides optional AUTROFIELDBUS earth fault detection.

The AUTROFIELDBUS cable is normally 2-wire twisted pair category 5 copper cables, however, fibre optic cable is possible by use of separate signal converters. The AUTROFIELDBUS uses the same guidelines as AUTROLON, in terms of cable lengths, fibre modem and boosters.



Technical Specifications

Dimensions (mm)	114,5 x 120 x 45
Weight (g)	250 g
Housing material	Polyamide 6.6.
Mounting	DIN TS-35 rail
Power supply	18-32VDC
Current consumption	Typically 150-200 mA at 24VDC
Temperature range	-10 to +60 °C
Humidity	10% - 95% RH (non-condensing)
Degree of protection	IP 20
Communication loop	AUTROFIELDBUS
Cable terminals	Phoenix Combicon style Maximum 2.5 mm ² wires
Cable AUTROFIELDBUS	Refer to specification for AutoSafe AutoLON
Cable RS232	Maximum 3 metres

Layout / Dimensions

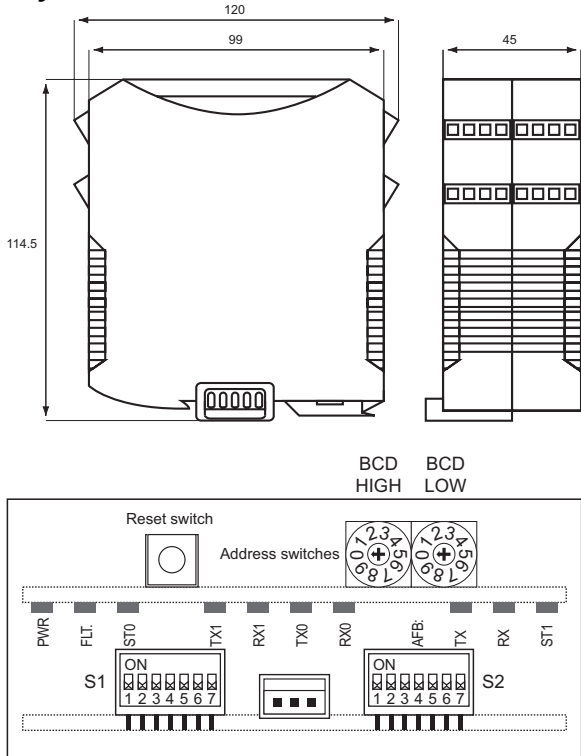

Connectors

All connections are made to plug-in screw terminals numbered 1-32.

Terminal	Function
1	AutroFieldBus A
2	AutroFieldBus A'
3	AutroFieldBus CT A
4	AutroFieldBus Earth Fault Sense
9	AutroFieldBus B
10	AutroFieldBus B'
11	AutroFieldBus CT B
12	AutroFieldBus Earth Fault Sense
25	TX RS232 Port 0
26	RX RS232 Port 0
27	Signal Reference Port 0
28	Instrument Earth Port 0
29	+24V Input
30	0V Input
31	Instrument Earth Common
32	Protective Earth Common

Unlisted connectors must be left unconnected!

LED indicators

PWR	green	Power & Heartbeat
FLT	red	EAU-341 Fault
ST0	yellow	AFB Message processed
TX1	green	Not in use
RX1	red	Not in use
TX0	green	Port 0 Transmits
RX0	red	Port 0 Receives
TX	green	AFB Transmits
RX	red	AFB bus traffic
ST1	yellow	AFB Message received

Order Numbers

Order number	Description
116-EAU-341	AUTROFIELDBUS Driver

Overview – Typical Installation

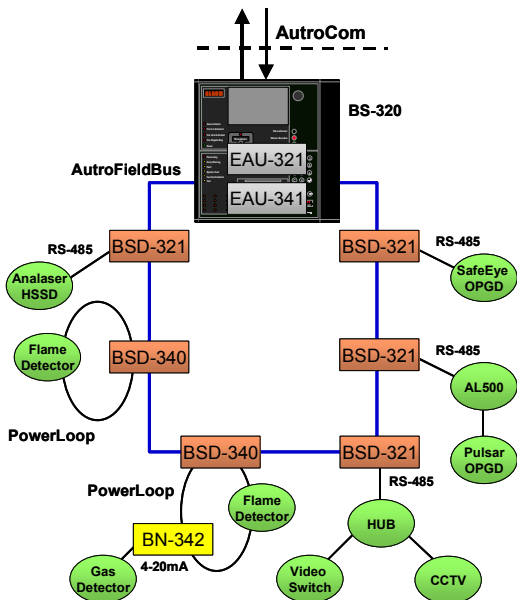

DIP switch settings for the EAU-341:

S1:	S2:
1 OFF	1 OFF
2 OFF	2 OFF
3 OFF	3 OFF
4 ON	4 ON
5 OFF	5 OFF
6 OFF	6 OFF
7 OFF	7 OFF

Panel interface:

The EAU-341 connects to AutoSafe via the EAU-321 Serial Port Communication Board. It uses COM3.

Autronica Fire and Security AS

Fire and Security, Trondheim, Norway. Phone: + 47 73 58 25 00, fax: + 47 73 58 25 01
 Oil & Gas, Stavanger, Norway. Phone: + 47 51 84 09 00, fax: + 47 51 84 09 99
 Maritime Sales, Spikkestad, Norway. Phone: + 47 31 29 55 00, fax: + 47 31 29 55 01

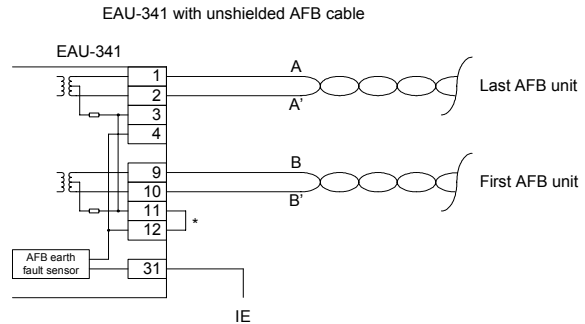
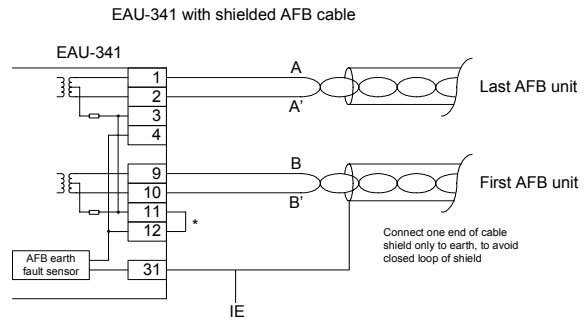
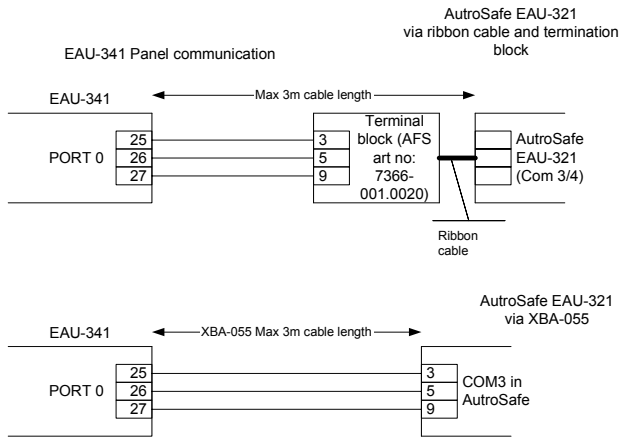

*: Connect if AFB earth fault detection is required. Detection will be done towards the IE terminal (31) If this link is unconnected, (11) must be connected to IE to reference the AFB.

The EAU-341 is intended for use either within the AutoSafe or within the same cabinet/rack as the panel. The cabling must be kept within the same cabinet/rack.

The EAU-341 is intended for use with 24VDC power supplies. It may be used in single or dual earth systems.

EAU-341 power, Single earth system

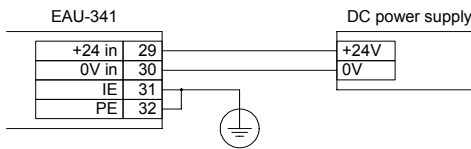

EAU-341 power, Dual earth system

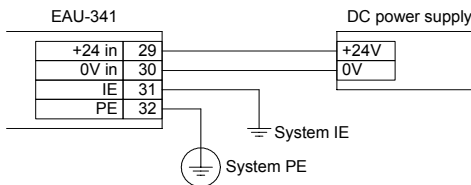

For further earth & shielding information reference to the System Description AutoSafe IFG. Order number: 116-P-ASAFE-IFG/XE.

Earth fault detection on AutoFieldBus

Earth fault detection may be enabled on the AutoFieldBus (AFB) interface. Earth fault detection can only be enabled on one unit on each cable segment on AFB.

Cable segments are isolated by using fibre modems (BSL-321/322) or boosters (BSL-325).

In systems with only one cable segment the AFB earth fault detection should be done by the EAU-341 unit.

Earth fault detection requires a connection between connector 11 and 12, and that the IE connector is connected to the same earth system that an optional cable shielding is connected to.

Autronica Fire and Security AS

Fire and Security, Trondheim, Norway. Phone: + 47 73 58 25 00, fax: + 47 73 58 25 01
 Oil & Gas, Stavanger, Norway. Phone: + 47 51 84 09 00, fax: + 47 51 84 09 99
 Maritime Sales, Spikkestad, Norway. Phone: + 47 31 29 55 00, fax: + 47 31 29 55 01