



Fireray One

With no specialist tools or knowledge needed for installation and operation, the Fireray One is a standalone beam detector that prioritises ease of installation.

Using the Fireray One, it couldn't be easier to bring the benefits of beam detection to your application:

- Auto-Aligns – just steer the laser onto the Reflector, then at the flick of a switch, it aligns itself. 8 times faster than previous detectors
- One person installation – everything can be done by one person
- One standalone product – no specialist tools required; minimal prior knowledge and training needed

Application	Challenge	Fireray One
Small warehouses	Cost effective protection	A standalone beam detector with all the benefits of Fireray Reflective beam detection
	Simple installation	Single point of wiring and commissioning
New buildings	Settling of the building can cause other beam detectors to misalign and result in nuisance alarms	Building Movement Tracking™ automatically compensates for natural building movement to continuously maintain alignment*



Technical specification

Detection performance	
Detection range	0 to 50m 0 to 120m with Reflective Long Range Kit
Alignment method	Laser assisted, Auto-Alignment™. Manual alignment – optional setting
Auto-Alignment™ protocol	Background check, Box search, Adjust and Centre
Building Movement Tracking™	Compensates for natural shifts in alignment from building movement*
Contamination Compensation	Compensates for gradual build-up of contamination on the optical surfaces
Light Cancellation Technology™	Compensates for high levels of sunlight and artificial lighting
Optical wavelength – smoke detection	850nm near infrared (invisible)
Integrated laser – laser alignment	650nm visible. Class 3R <5mW
Dynamic Beam Phasing	Allows beam detectors to be mounted facing each other with the reflectors in the middle. Eliminates false alarms caused by crosstalk between beams
Signal output	Individual Alarm and Fault relays (VFCO) 0.5A @ 30 VDC
Programmable user settings	
Alarm response threshold levels	25% (1.25dB) – Fastest response to smoke 35% (1.87dB) – Default value 55% (3.46dB) – High immunity to false alarms, slow response to smoke 85% (8.23dB) – Highest immunity to false alarms, slowest response to smoke Configured via the integrated user interface
Delay to Alarm	10 seconds, for momentary partial obstruction of the beam path
Delay to Fault	10 seconds, for momentary obstruction of the beam path
User features	
Integrated user interface	Alignment mode switch, alignment directional buttons and configuration switches for alarm response threshold
Alignment status indication	2 Green LEDs and 1 Yellow LED
System status indication	Normal operation – Green LED flashing every 10 seconds Alarm condition – Red LED flashing every 5 seconds Fault condition – Yellow LED flashing every 10 seconds for obscuration or every 5 seconds for contamination
Cleaning	Flat front face with enclosed optics. Cleaning the optics does not affect alignment

Design parameters	
Separation distance between Detector and Reflector	5 to 50m
	50 to 120m with Reflective Long Range Kit
Beam path clearance	1m in diameter from centre line between Detector and Reflector
Detector dimensions	Width 130mm x Height 181mm x Depth 134mm (see diagram)
Reflector dimensions	Up to 50m separation distance – Single reflector 100mm x 100mm x 9mm Up to 120m separation distance – Four reflectors arranged in a square pattern 200mm x 200mm x 9mm
Product weight	Detector – 0.7kg; Reflector – 0.1 kg
Multi-detector arrangement	Dynamic Beam Phasing allows for Detectors to face each other with the reflectors in the middle
Housing colour	White RAL9016, UV stable

Electrical specifications	
Operating voltage	14 to 36 VDC
Operating current (constant) all operational modes	All operational modes – 5mA; Fast alignment mode – 33mA

Field wiring	
Cable gauge and type	2 core, dedicated, 0.5 to 1.6mm (24 to 14 AWG) System compatible with fireproof and non-fireproof cable meeting local installation standards
Cable entry	3 knock-out locations capable of accepting M20, ½" or ¾" glands 4 drill-out locations capable of accepting glands up to 21 mm diameter

Test and maintenance	
Alarm test	Optical alarm test using Commissioning and Maintenance Kit accessory

Environmental specifications	Optical specifications
Operating temperature: -20 to +55°C	Fault level / Rapid obscuration ($\Delta \leq 2$ seconds): $\geq 85\%$
Storage temperature: -40 to +85°C	Maximum angular alignment of Reflective Detector: $\pm 4.5^\circ$ ($\pm 70^\circ$ with adjustment bracket accessory)
Relative humidity (non-condensing or icing): 0 to 93%	Maximum angular misalignment of Reflective Detector: $\pm 0.5^\circ$
IP rating: IP55	Maximum angular misalignment of Reflector: $\pm 5^\circ$
Housing flammability rating: UL94 V0 polycarbonate	

All figures are quoted for 25°C

Ordering information

Part number	Description
6010-100	Fireray One – 50m detection range
1010-000	Reflective Long Range Kit – 120m detection range

Accessories

1150-000	Commissioning and Maintenance Kit
1170-000	Reflective Detector adjustment bracket
1100-000	Fireray One Protective cage
1040-000	Single Reflector Adjustment Bracket
1050-000	4 Reflector Adjustment Bracket
1030-000	Reflector wall bracket - white
1031-000	Reflector wall bracket - black
1060-000	Fireray One Anti-condensation heater
1090-000	Reflector Anti-condensation heater
1260-000	Fireray One Back Box

Approvals

UL268
2831-CPR-F2237
Vds G 218070



Patents:
Light Cancellation Technology™ Patent No. GB2513366
Dynamic Beam Phasing Patent No. GB2551546
Auto-Alignment™ Patent No. GB2551373

*When mounted according to manufactures guidelines.

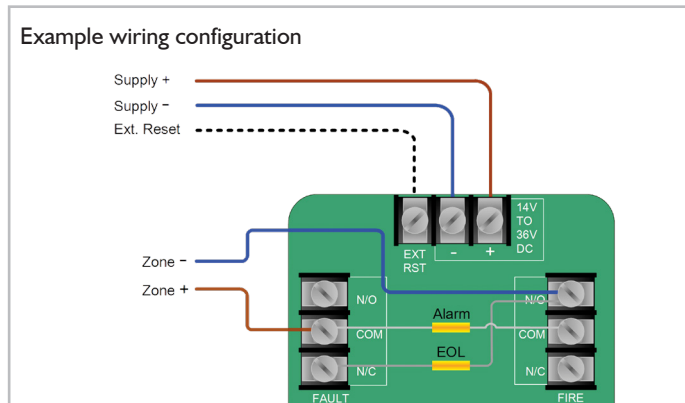

Dimensions

