

Multi mode fibre optic converter - BSL-321

AutoSafe interactive fire detection system
Product datasheet

Features

- Converts data signals on an AutoSafe Local operating network (AUTROLON) or an AutoSafe AutoFieldBus ring to fibre optic signals
- Ensures reliable communication where larger distances on AUTROLON or AutoFieldBus are necessary
- Easily plugged onto other I/O modules on a standard mounting rail inside the Fire alarm control panel/ controller
- Powered from the I/O module stack or from an external power supply connected to screw terminals
- Designed and tested to meet EN 54 requirements and conforms to CE standards
- Uses 1300nm technology
- Uses multi mode 62,5/125µm or 50/125µm fibre optic cable
- Network traffic monitor

Applications

The Multi mode fibre optic converter BSL-321 is used to boost the electrical data signals on the AutoSafe Local operating network; AUTROLON, or on AutoFieldBus, and convert the signals to and from optical fibre communication.

The converter ensures reliable communication in cases where larger distances between panels are necessary. By using optical converters the total installation length can be greatly increased (see requirements and limitations below).

The BSL-321 can be placed anywhere in the electrical AUTROLON network or in an AutoFieldBus ring and is not required to be mounted inside a panel.

If the converter is mounted on the standard mounting rail inside the fire alarm control panel/controller it will be powered with 24 VDC from the I/O module stack. If the module is not mounted on the standard mounting rail, external 24 VDC power must be supplied to the screw terminals.

Requirements

If a combination of BSL-321 and/or BSL-322 (fibre optic converters) is used with BSL-325 AUTROLON boosters, the required number of fibre "jumps" is reduced according to the table below. For BSL-325 limitations, refer to the BSL-325 datasheet.

Number of BSL-325s in the AUTROLON ring	Maximum number of fibre jumps
0	8
2	7
3-4	6
5-6	5

Limitations

- Requires duplex fibres (2 actual fibres) between BSL-321 units.
- A maximum of 1000 meters of copper wire or 8 panels is permitted between any two BSL-325 AUTROLON boosters.
- A maximum of 3000 m of optical fibre and 6dB optical attenuation between two BSL-321 units.
- A maximum of 32 panels per AUTROLON ring.



Connections/indicators

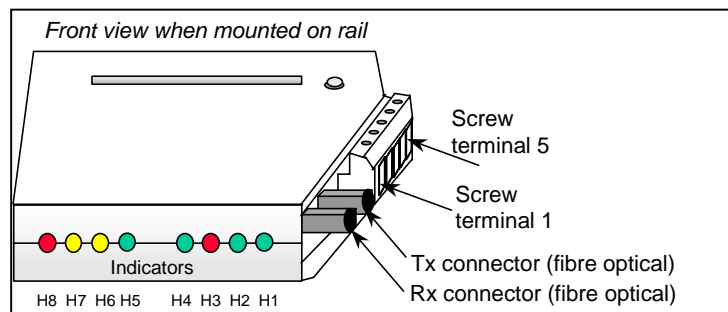

- H1 green LED, LON (fibre) transmitter active
- H2 green LED, LON (copper) transmitter active
- H3 red LED, not used
- H4 green LED, module OK when blinking
- H5 green LED, > 0,01 % network load
- H6 yellow LED, > 1 % network load
- H7 yellow LED, > 10 % network load
- H8 red LED, > 50 % network load

The BSL-321 module has the following connections:

Screw terminal no.	Signal
1	LON (polarity independent)
2	LON (polarity independent)
3	Shield LON
4	+24VDC supply
5	0VDC supply

Optical connectors	Signal
Rx	Receive optical signal
Tx	Transmit optical signal



Technical specifications	
Dimensions (mm) HxDxW	95x89x32
Weight (g)	81
Materials	Top and bottom: Zytel FR7200 Snap on mounting device: Zytel 7335S
Mounting	Onto a standard 35mm mounting rail inside the Fire alarm control panel, controller or separate box.
Electrical connection	Internal system: plug in connection Screw terminals (maximum cable dimension 2,5mm ²)
Supply voltage	21 - 29 VDC
Internal current consumption	Maximum 100mA, typically 30mA
Degree of protection	IP20
Humidity	93% relative humidity at 40°C
Temperature (working)	-20 to +60°C
Cable specification	Twisted pair, 100 Ohm characteristic
Optical fibre cable specification	62,5/125µm or 50/125µm Maximum distance 3000m Maximum attenuation 2db/km
Fibre connector type	ST
Optical wavelength	1300nm
Recommended maximum cable length	3000m

Part number	Description
116-BSL-321	Multi mode fibre optic converter

Block diagram – typical examples

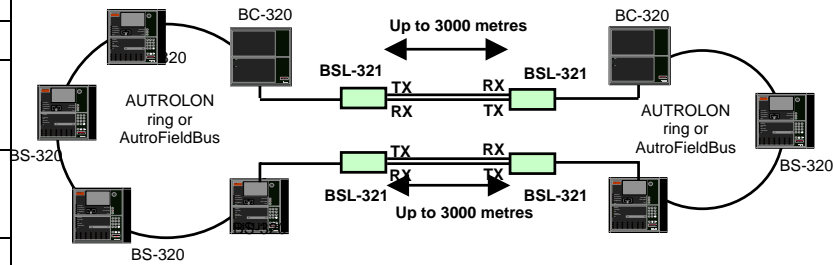

Example of a combined copper (indicated with a thick line) and fibre optic network (indicated with double thin lines).

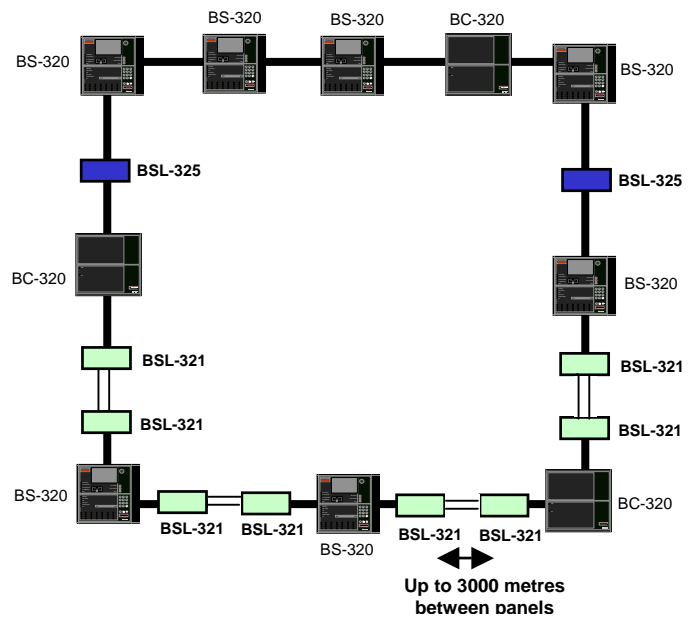

Schematics – overview connections

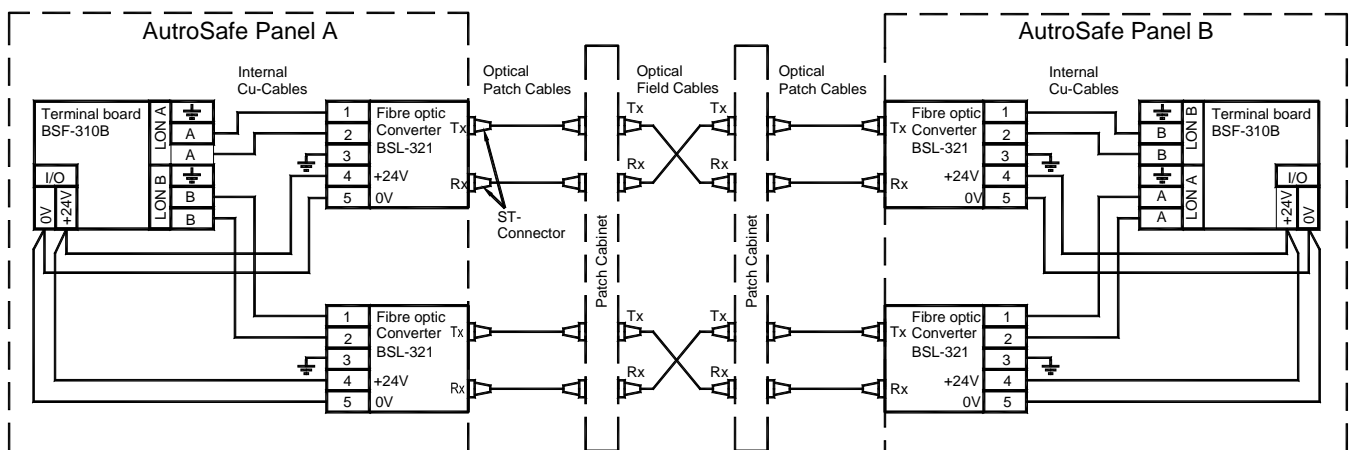

AUTRONICA FIRE AND SECURITY AS

Head office, NO-7483 Trondheim, Norway Tel: +47 73 58 25 00, fax: +47 73 58 25 01, e-mail: info@autronicafire.no
 Oil and Gas division, Stavanger, Norway Tel: +47 51 84 09 00, fax: +47 51 84 09 99
 Maritime division, Spikkestad, Norway Tel: +47 31 29 55 00, fax: +47 31 29 55 01