



Instructions

AutroFlame IR Flame Detector BG-201



COPYRIGHT ©

This publication, or parts thereof, may not be reproduced in any form, by any method, for any purpose.

Autronica Fire and Security AS and its subsidiaries assume no responsibility for any errors that may appear in the publication, or for damages arising from the information in it. No information in this publication should be regarded as a warranty made by Autronica Fire and Security AS. The information in this publication may be updated without notice.

Product names mentioned in this publication may be trademarks. They are used only for identification.



This product contains static-sensitive devices. Avoid any electrostatic discharge.

The WEEE Directive

When the marking below is shown on the product and/or its literature, it means that the product should not be disposed with other household wastes at the end of its life cycle. During waste treatment, disposal and collection, please separate the product from other types of wastes and recycle it responsibly to promote the sustainable reuse of material resources. This product should not be mixed with other commercial wastes for disposal.

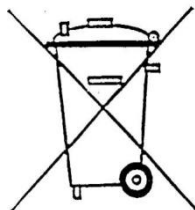
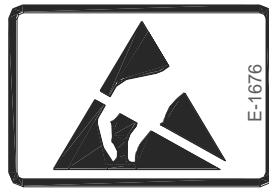

Table of Contents

| | |
|--------------------------------------|----------|
| 1. Introduction..... | 0 |
| 1.1 About the Handbook..... | 0 |
| 1.2 The Reader | 0 |
| 1.3 Reference Documentation..... | 0 |
| 2. AutoFlame BG 201..... | 1 |
| 2.1 Features | 1 |
| 2.2 Applications | 1 |
| 2.3 Principle..... | 1 |
| 2.4 Technical Specifications..... | 2 |
| 2.5 Performance Classes | 2 |
| 2.6 Mode selection | 3 |
| 2.7 Connection | 3 |
| 3. Dimensions | 4 |
| 4. Installation..... | 5 |
| 4.1 Detector installation..... | 5 |
| 4.2 Cable | 5 |
| 5. Mounting | 6 |
| 6. Field of View..... | 8 |
| 7. Test and Maintenance | 9 |

1. Introduction



This product contains static-sensitive devices.
Always use an antistatic wrist strap / ground bracelet to avoid any electrostatic discharge.

1.1 About the Handbook

This handbook is intended to provide all necessary information for the installation and commissioning of the AutoFlame IR Flame Detector BG-201 (for AI_Com detection loops) and BG-21 (for conventional detection loops).

1.2 The Reader

The handbook is intended to be used by Autronica Fire and Security trained service and technical personnel who are responsible for the installation and commissioning of the detector.

1.3 Reference Documentation

The table below shows an overview of the technical marketing documentation for the flame detector.

| Document Name | Part number | File name |
|---------------|-----------------|-----------|
| Datasheet | 116-P-BG201/CGB | bg201_cgb |
| Datasheet | 116-P-BG21/CGB | bg21_cgb |
| Instructions | 116-P-BG201/DGB | bg201_dgb |
| Instructions | 116-P-BG21/DGB | bg21_dgb |

2. AutroFlame BG– 201

The AutroFlame IR Flame Detector BG-201 is to be used on AI_Com detection loops (for interactive fire detection systems).

2.1 Features

- Fast detection of hydrocarbon fires.
- Interactive
- Different sensitivity settings possible
- Short circuit isolator in each detector
- Comprises a built-in alarm indicator (LED)
- Automatic addressing
- Solar resistant
- Not blinded by oil film on window
- High degree of immunity to false alarm sources
- EN54-10, EN54-17 approved
- Designed to meet the requirement of the major maritime classification societies

2.2 Applications

BG-201 is a point flame detector for detection of fires involving combustion of carbonaceous materials.

The detector has a high IP rating making it suitable for the harshest environments.

The detector can be used for interactive AI_Com version for connection to AutoSafe / Autroprime detection.

Performance class can be configured by the system according to table 2.

The advanced signal processing and DYFI+ intelligence ensure that the detector has a high immunity to any nuisance alarm source combined with fast detection of real fires. This makes the BG-201 the obvious choice for demanding applications such as a ship's engine room.

2.3 Principle

Dual IR sensor responding to the radiated IR signal from a fire. Two infrared sensors detects the infrared spectrum of a hydrocarbon fire. The sensor signals is processed to verify the characteristics of a flame, and also use this information for improved false alarm rejection.

2.4 Technical Specifications

Table 1.

| Technical specifications | |
|--|---|
| Weight | 210 g |
| Materials | Polycarbonate, sapphire glass. |
| Colour | Transparent / light grey |
| Sensitivity | Ref. table 2 |
| Field of View | Horizontal= \pm 45°, Vertical= \pm 30°/-45° (see the Field of view diagram on page 17 for additional EN 54-10 Information) |
| Voltage. | Supplied from detection loop |
| Current consumption: Stand by | 90 μ A |
| Current consumption: Alarm LED on | 2,1 mA |
| Degree of protection | IP66 and 67 |
| Working temperature, storage temperature | -40 to +70°C |
| Storage temperature | -40 to + 70°C |
| Humidity | 0-96% rh, can withstand 100% condensing humidity for short periods of time |
| Maintenance | Cleaning of window |
| Service | Replace if faulty |
| Approvals | See web site |
| Cable size (cable gland) | 6-12mm |
| Wire size (terminal block) | Maximum cable 2,5mm ² / AWG14 |
| Approvals | Refer to product website http://product.autronicafire.com/products/ |

2.5 Performance Classes

Table 2



| Performance class | Range |
|-------------------|------------|
| Class 1* | Up to 25 m |
| Class 2 | Up to 17 m |
| Class 3* | Up to 12 m |

The Performance classes is according to EN54-10. They can be set by the configuration in AutoSafe / Autoprime. The 3 different classes can be chosen for the Standard mode only.

When the detector mode is set to Legacy, the detector will run in performance class 2 and can not be changed. (Up to 17 mtrs.)

2.6 Mode selection

Table 3

| Mode selection, cutting of jumpers on PCB | J4 |
|---|---|
| STANDARD: AutoSafe / Autoprime mode |  |
| LEGACY: FDI compatible mode |  |

Standard mode means that the detector will run as BG-201 on newer versions of AutoSafe and Autoprime.

In Legacy mode the detector emulates the Flame detector interface (FDI) used for the 601F detector. When BG-201 is used to replace the FDI and 601F detector in an AutoSafe V4 or older, J4 jumper should be cut.

2.7 Connection

Up to 127 BG-201 detectors can be connected to an AutoSafe/Autoprime detection loop. The detector is provided with a pluggable terminal block for ease of connection.

Interactive loop connection:

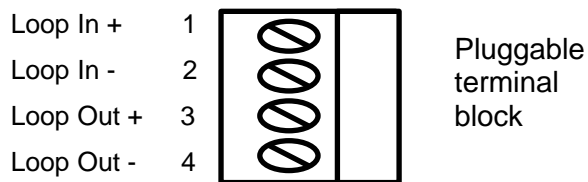

Terminal:
1 2 3 4

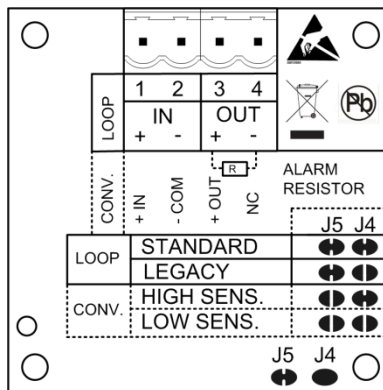

3. Dimensions

Figure 1 – Dimensions

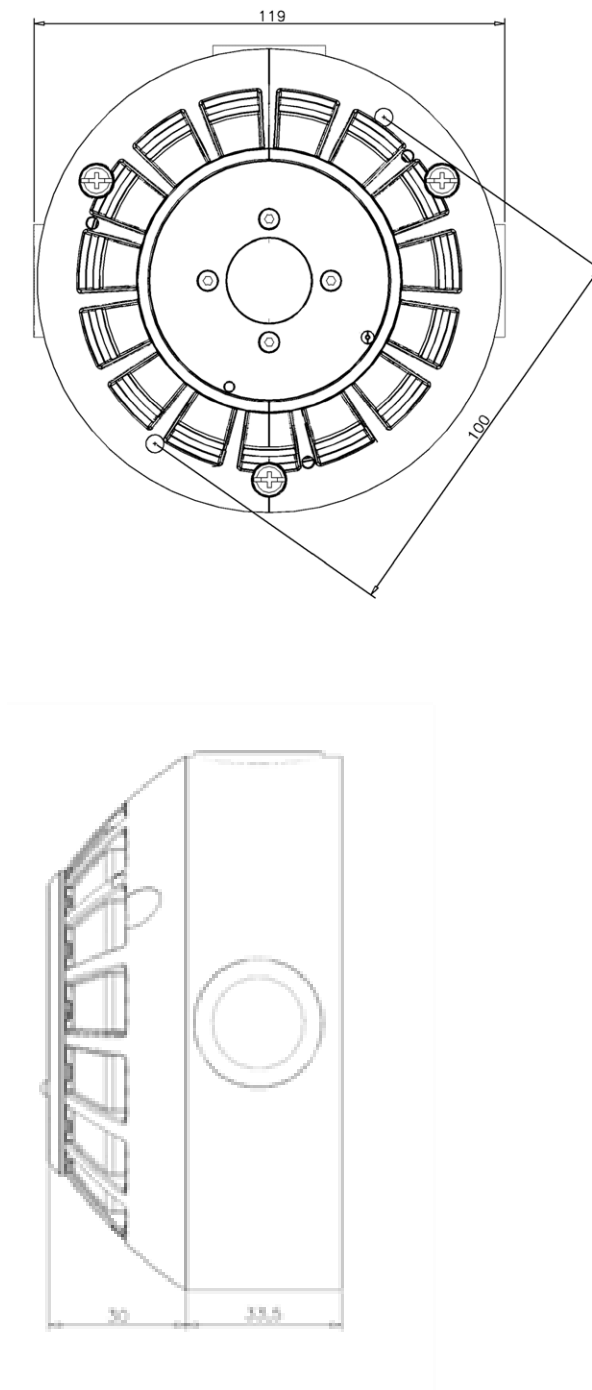

4. Installation

4.1 Detector installation

Detectors should be positioned to give the best possible coverage of the protected area. Any obstructions must be taken into consideration, and if necessary additional detectors must be installed to cover the blind spots.

It is also important to consider the different points below:

- If the flame detector is protecting a specific object, make sure that the detector field of view and sensitivity class is set correctly to cover the fire risks of the object.
- Be sure that enough detectors are used to adequately cover the complete risk areas.
- The detector should be mounted in way that makes it accessible for cleaning and servicing.
- If a large area is protected by flame detectors, make sure that all fire risks are within the field of view and at an acceptable detection range (see table for class settings).
- For indoor application it must be considered that heavy smoke from a fire may affect the sensitivity, so the detector should not be installed directly above a risk area where smoke will accumulate between the fire and the detector. Normally the best position to mount the detector will be on the walls about 1 meter below the ceiling.
- For outdoors applications it must be considered that heavy rain, dense fog and ice on the lens will absorb some of the IR from a fire, reducing the detection range.

4.2 Cable

The detector is delivered with 2 cable glands for cable diameter 6 – 12 mm. In order to maintain the IP rating of the enclosure the cable diameter must be within this range.



If other cable size is required the glands should be replaced accordingly..



If the loop cable has a screen, there is a twist wire connector provided with the detector in order to connect the in/out screens together in the base.

The screen must be connected to earth in one end only. This will normally be at the panel.

5. Mounting

Detector Mounting

The detector should be mounted on a rigid surface and pointing down at least 10° in order to prevent water accumulation on the lens. If the detector is mounted on a wall and aimed 45° downwards the coverage would be vertically downwards in parallel to the wall and 45° horizontal to both sides of the centreline.

Figure 2 - mounting

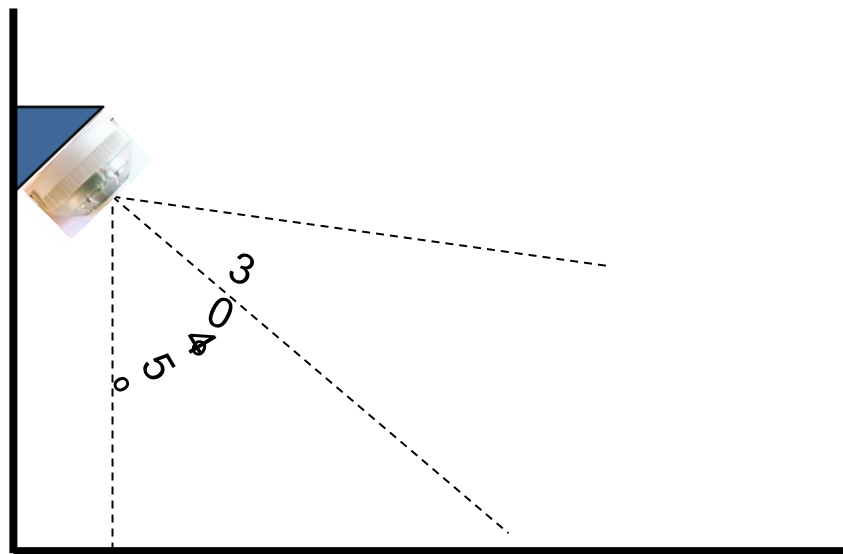
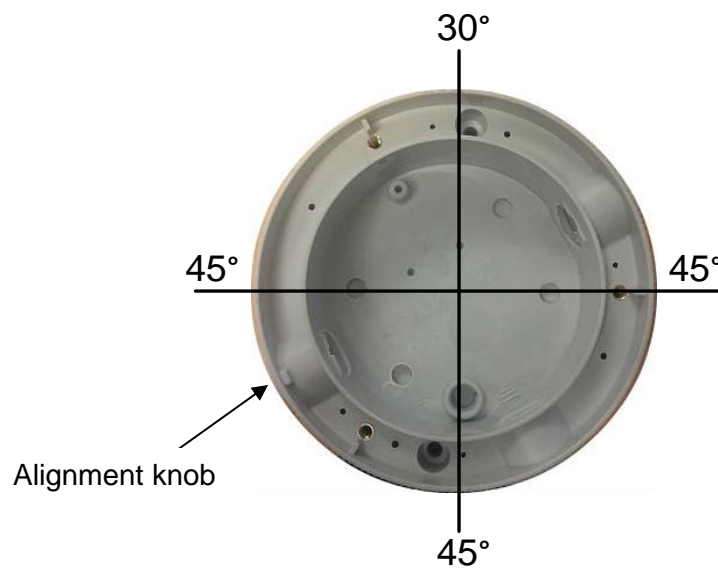
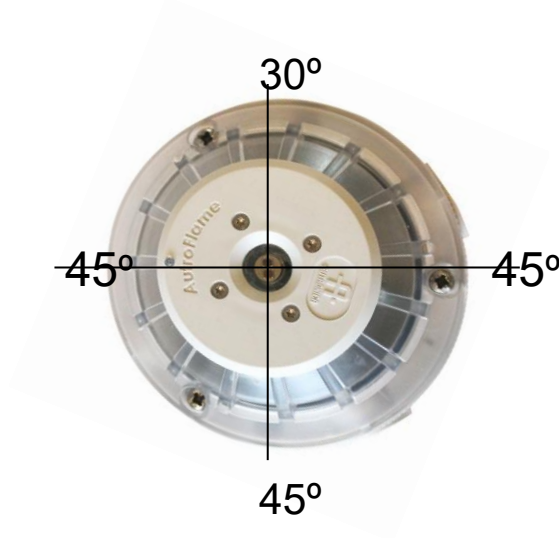

Fig. 3 shows how to mount the detector base in order to have vertical FOV $+30^\circ/-45^\circ$ and horizontal FOV $\pm 45^\circ$.



Observe that there is an alignment knob provided on the base so that there is only one correct direction to fit the head on the base. If the base is installed as shown above, the FOV will be like shown below when the head is fitted to the base.



6. Field of View

When mounting the detector the Field Of View (FOV) must be taken into consideration.

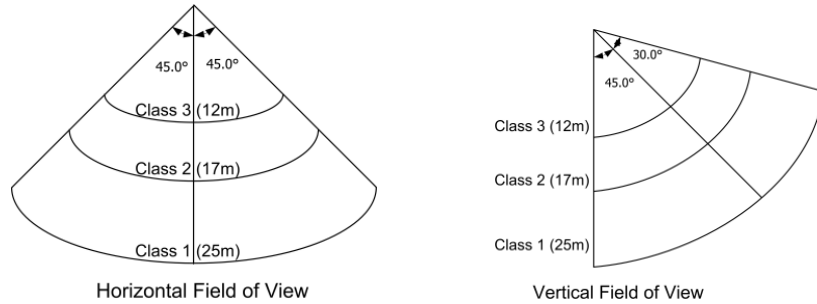

To comply with the directional dependence requirements for EN 54-10:2002 an angle of $\pm 30^\circ$ from 0° (0° = Orientation of detector in same axes as flame source) should not be exceeded, based on lab testing at a distance of approximately 5.0 ft (1.5 m).

In order to have the FOV described above, the detector must be oriented with the “marking showing top” as shown in the figure below.

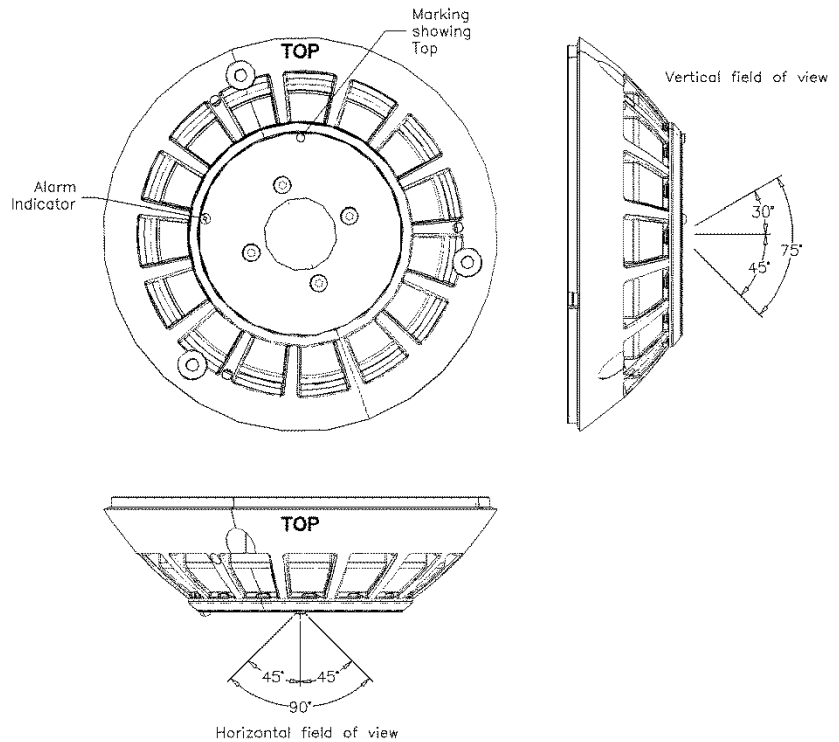

7. Test and Maintenance

When installation of the flame detector is complete, an alarm test should be performed. Because of the built in intelligence, the detector will not activate an alarm on artificial influence like a simple test lamp. Several ways of testing is described below:

The best way to test the detector (as for any other flame detector) is to use a real flame from the type of fuel that presents the risk in the protected area.

Flames from handheld torches (~3pcs) should also work fine within the specified coverage distance.

Alternatively a test with standardized n-heptane fire described in EN54-10 could be done. This test should activate the detector in less than 30 seconds.

A simple test can also be performed using a normal gas lighter at close range (<1m) or a portable Bunsen burner (1-2m). Moving the flame in a random flickering pattern will help setting off the alarm.

We are also providing an IR test lamp that will set the detector in alarm when operated correctly. The test lamp needs to be placed on the detector using a telescopic pole (max 4m + person). The part number for this test lamp including telescopic pole and carrying suitcase is 116-Z-TL-2056.

It is possible to test the flame detector with a test-lamp intended for testing IR flame detectors at distance as well, making the detector recognize a test pattern.

Follow the instructions on the next page to make the special test pattern.

Test Procedure: Testing BG-201 with IR testlamp

Testing without ALARM from detector

A simple test can be performed to test that the glass, sensor and signal processing is working properly.

- Flash with the lamp at the detector until the LED shortly turns ON. The LED feedback indicates that the detector has seen the flashing.

The detector will NOT signal ALARM.

Testing with ALARM from detector

1. FLASH with the lamp at the detector until the LED blinks.
2. STOP flashing until the LED blinks again.
3. FLASH with the lamp at the detector until the LED blinks.
4. STOP flashing until the LED blinks again.
5. FLASH with the lamp at the detector until the LED blinks.
6. STOP flashing until the LED blinks again.
7. FLASH with the lamp at the detector until the LED turns ON permanently.

The detector signals ALARM to the system

Maintenance

To maintain maximum sensitivity and false alarm immunity, the window of the detector must be cleaned in regular intervals depending on the rate of pollution.

The window can be cleaned buy using a soft cloth or cotton swab (Q-tips) with a mild dishwashing detergent.

Note!

Do not use any chemicals or fluids for cleaning which is incompatible with Polycarbonate as this can harm the plastic parts of the detector.

Autronica Fire and Security AS

Bromstadveien 59, 7047 Trondheim, Norge | Tlf: +47 90 90 55 00 |

E-mail: info.autronica@carrier.com | www.autronicafire.com