

FIRE AND SECURITY

AUTRO SAFE

Self Verify®

Integrated Fire & Gas Detection System (IFG)



System Description

AutroSafe IFG



Protecting life, environment and property...

116-P-ASAFE-IFG/XE Rev. B, 2005-10-27

COPYRIGHT ©

This publication, or parts thereof, may not be reproduced in any form, by any method, for any purpose.

Autronica Fire and Security AS and its subsidiaries assume no responsibility for any errors that may appear in the publication, or for damages arising from the information in it. No information in this publication should be regarded as a warranty made by Autronica Fire and Security. The information in this publication may be updated without notice.

Product names mentioned in this publication may be trademarks. They are used only for identification.



Table of Contents

1. Introduction	4
1.1 About the Handbook	4
1.2 The Reader	4
1.3 Reference Documentation	4
2. System Overview	5
2.1 Definitions	5
2.2 System Example	6
3. IFG Functionality	7
3.1 Introduction	7
3.2 Inhibit Point	7
3.3 Set Alarm Limits	7
3.4 Get Measurement Values	7
3.5 Detection Zone faults and Point faults	8
3.6 Fixed delay of Output (FPE) activation	8
3.7 Support for Common Trouble Output	8
3.8 Support for Gas Detectors (4-20 mA input)	8
3.9 Support for Detectors Communicating on RS-485 (from SW 3.5.0)	9
3.10 Support for Extinguishing Control Unit	9
3.11 Local/External mode functionality	10
3.12 Support for MicroPack Video Switch	10
3.13 Language	10
4. System Hardware	11
4.1 System Panels	11
4.2 AutoFieldBus Driver EAU-341	13
4.2.1 Description	13
4.2.2 Overview	13
4.2.3 Connections to EAU-341	14
4.2.4 Earthing and shielding of EAU-341 and AutoFieldBus	14
4.2.5 Connection between EAU-321 and EAU-341	16
4.2.6 Capacity / Limitations	16
4.2.7 Jumper Settings for the EAU-321 board	17
4.3 PowerLoop Driver BSD-340	18
4.3.1 Description	18
4.3.2 Overview	18
4.3.3 Connections	19
4.3.4 Earthing and shielding	19
4.3.5 Capacity / Limitations	20
4.4 PowerLoop 4-20 mA Input Unit BN-342	21
4.4.1 Description	21
4.4.2 Versions	21
4.4.3 Options selected in AutoSafe Configuration Tool	21
4.4.4 Overview	22

4.4.5	Connections	22
4.4.6	Connection – current source.....	23
4.4.7	Connection – current sink	23
4.5	PowerLoop 4-20 mA Input Unit BN-342/EX.....	24
4.5.1	Description	24
4.5.2	Versions	24
4.5.3	Overview	24
4.5.4	Connections	25
4.5.5	Earthing.....	25
4.6	AutoFlame Multispectrum Flame Detector X33/1 PL	26
4.6.1	Description	26
4.6.2	Applications	26
4.6.3	Connections	27
4.7	AutoPoint Gas Detector HC300 PL	28
4.7.1	Connections	29
4.8	AutoFieldBus Protocol Converter BSD-321	30
4.8.1	Description	30
4.8.2	Overview	30
4.8.3	Connections	31
4.8.4	Earthing.....	35
4.8.5	Typical applications using different signal references	36
4.8.6	Port Isolation on RS-422 ports.....	39
5.	Projecting Guidelines	40
5.1	General Recommendations / Planning	40
5.2	Technical Overview.....	40
5.2.1	Limitations - Panels and Loop Units	40
5.2.2	Loop data	41
5.2.3	Cable data.....	42
5.2.4	Connectivity.....	43
5.2.5	Power Supply data.....	43
5.3	Typical System Configurations - Examples	43
5.3.1	Floating production, storage and offloading system	43
5.3.2	Offshore platform systems.....	44
5.3.3	Land-based petrochemical system.....	44
5.4	Mounting.....	44
5.5	Configuration	44
5.6	System Shielding and Earthing	45
5.6.1	Introduction	45
5.6.2	Definitions	45
5.6.3	Single Earth Systems – Power Loop	46
5.6.4	Dual Earth Systems – Power Loop.....	48
5.6.5	Shielding & Earthing AutoFieldBus.....	49
5.6.6	Earth Fault Detection AutoFieldBus	50
6.	PowerLoop Calculator Tool	51
6.1	Introduction.....	51
6.2	Operating The PowerLoop Calculator Tool.....	52
6.2.1	Loop driver type	52
6.2.2	Add Button	52
6.2.3	Insert Row Button	53
6.2.4	Update Row Button.....	53
6.2.5	Delete Row Button	54
6.2.6	Load Config Button	54
6.2.7	Calculate Button.....	54
6.2.8	Graphical Button	55
6.2.9	Ambient Temperature	56

6.2.10	Save and Load File	56
6.2.11	American Wire Gauge (AWG)	57
7.	Operation.....	58
7.1	IFG-specific Menus	58
7.2	Menu Structure – AutoSafe 3.5.0 - IFG	59
7.3	Show Status Menu / Oil&Gas Inhibited Points	60
7.3.1	Show Status – Oil & Gas Inhibited Points.....	61
7.4	Service Menu / Oil&Gas Commands	62
7.4.1	Inhibit Point	62
7.4.2	Cancel Inhibit Point	64
7.4.3	Set Alarm Limits	66
7.4.4	Get Measurement Values	68
7.5	Show All Points	70
8.	Troubleshooting.....	71
8.1.1	BSD-321 /EAU-341	71
8.1.2	Examples of Fault Messages:.....	72
9.	Reader’s Comments	81

1. Introduction

1.1 About the Handbook

This handbook is intended to provide supplementary information for the AutoSafe Integrated Fire & Gas System.

1.2 The Reader

This supplementary documentation is intended to be used by trained service and technical personnel who are responsible for the configuration, installation, commissioning or operation of the *AutoSafe Integrated Fire & Gas System*.

1.3 Reference Documentation

The standard documentation for the AutoSafe Interactive Fire Alarm System is listed below.

Handbook	Item Number
System Specification	P-ASAFE/XE
Installation Handbook, Fire Alarm Control Panel (BS-310/320) / Controller (BC-320)	P-ASAFE-FA/DE
Installation Handbook, Operator Panel (BS-330)	P-ASAFE-OP/DE
Installation Handbook, Repeater Panel (BU-320) / Information Panel (BV-320)	P-ASAFE-RI/DE
Commissioning Handbook	P-ASAFE/EE
Operator's Handbook, Fire Alarm Control Panel (BS-310/320) / Operator Panel (BS-330)	P-ASAFE-FO/FE
Operator's Handbook, Repeater Panel (BU-320)	P-ASAFE-FB/FE
Operator's Handbook, Information Panel (BV-320)	P-ASAFE-IN/FE
Shortform User Guide	P-ASAFE-SH/LE
Wall Chart	P-ASAFE-WE/LX
Wall Chart	P-ASAFE-CH/LX
Menu Structure	P-ASAFE-IFG/MX
User Guide, Loop Diagnostic Tool, AS-2000	P-ASAFE-AS/FE
User Guide, Loop Simulator Tool	P-ASAFE-LS/FE
User Guide, Loop Calculator Tool	P-ASAFE-LC/FE
User Guide, Merge Tool	P-ASAFE-MT/FE

Note:

For information about AutoOS; a networked, flexible and scalable control and monitoring system for AutoSafe systems, refer to separate documentation for *AutoOS*.

2. System Overview

2.1 Definitions

- **AI_Com** is the communication protocol for the AutoSafe Detection Loop.
- **AUTROLON** is AutoSafe's Local Operating Network.
- **AutoFieldBus** is used to communicate with a BSD-340 interface and BSD-321.
- **PowerLoop** is a two-wire bus capable of delivering 30VDC/ 100W connected in ring topology and is galvanically isolated from the rest of the system. The PowerLoop interfaces detectors and other loop units including a 4-20mA interface.
- **System Unit** is a unit that is directly connected to the local operating network; *AUTROLON*.
- **Loop Unit** is;
 - a Point, an I/O-unit or an Electronic Sounder connected to an AI_com Detection Loop.
 - a Point connected to a *PowerLoop*.
 - a Point connected to an AutoFieldBus Protocol Converter.
- **Point** is either a *detector* or a *manual call point*.

2.2 System Example

The illustration below depicts a system consisting of panels networked on an AUTROLON network. For compliance with C.E.N. regulations (EN-54), and for optimal safety, the AUTROLON must be installed as a ring loop. A maximum of 32 system units can be networked in this way.

In the example, AI_Com communication is used to communicate with standard loop units and standard Ex-certified loop units. AutoFieldBus is used to communicate with a BSD-340 interface (which is used to interface with a PowerLoop). An additional interface can connect multiple system units to external systems using either single-line Ethernet or dual serial (RS232).

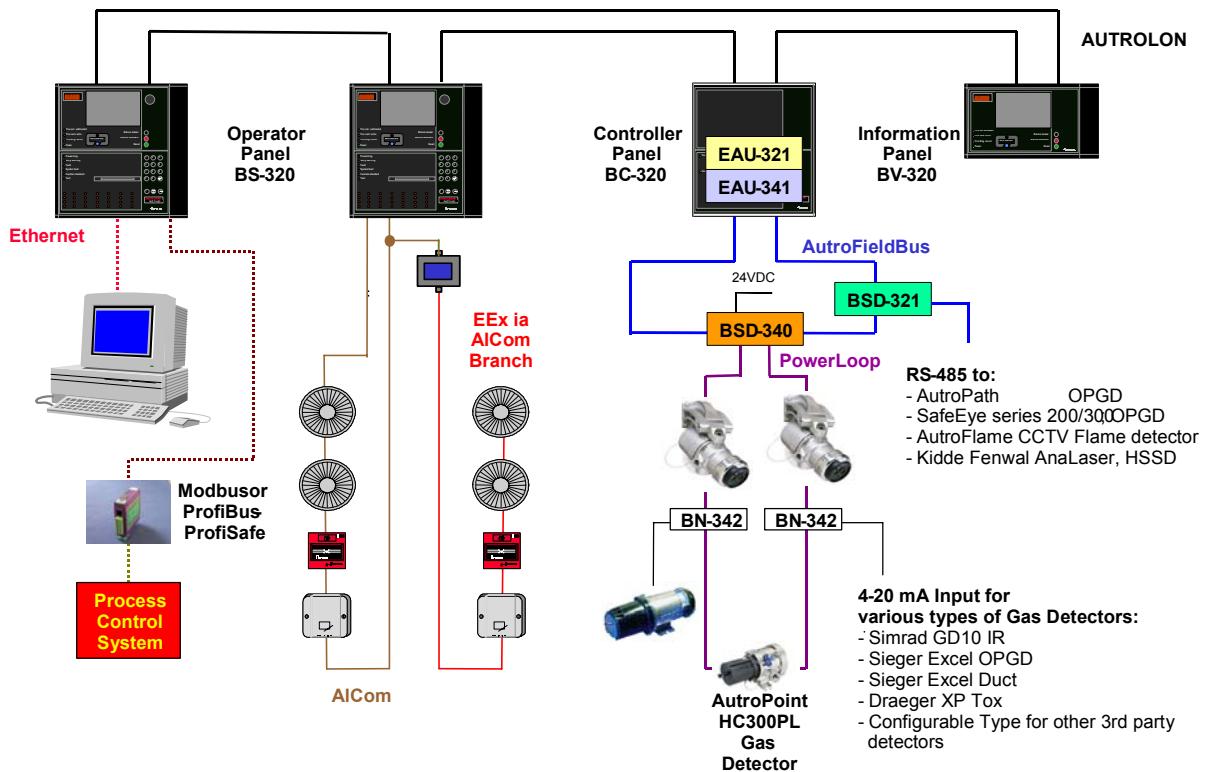

3. IFG Functionality

3.1 Introduction

This chapter covers some of the distinctions between AutoSafe functionality for Oil and Gas panels and standard AutoSafe panels.

3.2 Inhibit Point

All loop input units can be inhibited. When one or several points are inhibited, the point(s) will not signal alarm to outputs. An inhibited point will however present an alarm, prealarm and early warning on all panels and AutoCom as usual. This includes panel buzzer, panel LEDs and panel LCD display.

It is only possible to inhibit a unit from the panel menu or via AutoCom. An inhibited point will be inhibited until the unit is uninhibited by a manual operation or by timeout.

3.3 Set Alarm Limits

By using the *Set Alarm Limits* (via the menu) is possible to change a gas detector's alarm limit for *Low Alarm* and *High Alarm*.

3.4 Get Measurement Values

By using the *Get Measurement Values* (via the menu) it is possible to get analogue measurement values for a selected gas detector.

Analogue values can be monitored on the panel or on the AutoOS.

3.5 Detection Zone faults and Point faults

In standard AutoSafe, a point fault is presented as a detection zone (DZ) fault; the point in fault can be accessed via the panel menu. Oil and Gas panels can also be configured to present point faults as DZ faults.

3.6 Fixed delay of Output (FPE) activation

AutoSafe can be configured such that extinguishing agent activation is subject to a delay period; this activation delay time indicates the period from when the activation criterion is fulfilled to when the actual activation takes place (default delay: 10 seconds).

3.7 Support for Common Trouble Output

The Common Trouble Output can be connected to a BSB-310, BN-310 or a BSJ-310 I/O module. The output is activated if any kind of fault occurs in the Operation Zone to which it is connected. In addition, any disablement or point inhibition within the Operation Zone will cause the unit to be activated.

3.8 Support for Gas Detectors (4-20 mA input)

The AutoSafe Integrated Fire and Gas Detection System supports the use of several gas detectors that are to be connected to the PowerLoop via the PowerLoop 4-20mA Input Unit BN-342. These include;

- Simrad GD10 IR
- Sieger Excel OPGD
- Sieger Excel Duct
- Draeger XP Tox

In addition, the interface includes a user-configurable type that may be used to interface other types of third party gas detectors.

3.9 Support for Detectors Communicating on RS-485 (from SW 3.5.0)

Release 3.5.0 (and future versions) supports the use of different detectors connected to the AutoFieldBus via the protocol-converter unit BSD-321.

Supported detectors are:

AutoPath, open-path gas detector
SafeEye series 200/300, open-path gas detector
AutoFlame CCTV flame detector and video switch
Kidde Fenwal AnaLaser HSSD

3.10 Support for Extinguishing Control Unit

The Extinguishing Control Unit is a digital output device which is connected to a BSD-310 or BSD-311 loop driver module via the standard ALCOM loop. Because manual extinguishing medium release activation will not be reported back to the system, it is recommended that manual release activation switches are connected to a Fire Alarm Interface Unit (BN-300) or connected to the manual release activation switch to an output controlled by the extinguishing unit activation.

Output activation criteria:

MFS (manual callpoint) within a defined group in alarm
Flame detector (camera) within a defined group in alarm
AutoOS (AutoCom) activation
Manual activation (activation of input A on unit)

Advanced output activation criteria:

Voted gas:

2 gas detectors within a defined group in alarm
1 gas detector within a group in Alarm and 1 gas detector within same group in prealarm

Output activation result:

All General Outputs within a local defined output group is activated

Disable/Isolate/Override:

The Extinguishing Control Unit is a special case; it controls its own disablement (override) state via a Field Isolate Switch, Switch activation breaks the connection between the unit output and the extinguishing agent solenoid (this is sensed by the unit output logic). Activation of this switch will disable the unit itself. In addition, activation can disable other general outputs.

Activation of switch causes:

Disablement of actual extinguishing agent unit
All General Outputs within a local defined output group is disabled

3.11 Local/External mode functionality

Local/External functionality is selected via the AutoSafe configuration tool, as default, it is switched off (Local mode only). When switched on, the system toggles between the following modes:

External mode: AutoSafe is operating together with an external system (with no communication faults or internal faults). The external system is able to control extinguishing agent activation. The External mode extinguishing agent delay is controlled by a configured activation delay parameter called External Activation Delay (default delay: 60 seconds).

Local mode: An external system is either disconnected or has internal faults and the system is not able to control extinguishing agent activation. The Local mode extinguishing agent activation delay is controlled by the configured extinguishing agent activation delay parameter mentioned above (default delay: 10 seconds).

3.12 Support for MicroPack Video Switch

The video switch is only activated by external equipment (AutoOS) via AutoCom. The activation signal has additional information regarding switch settings to route the video signal to a given channel.

3.13 Language



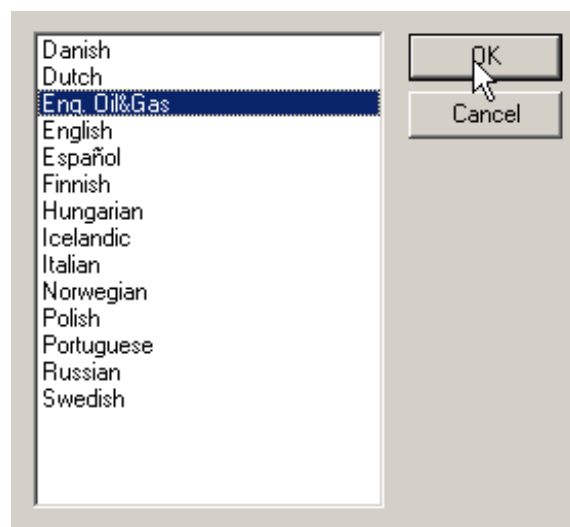

The panels prepared for the Oil and Gas market are available in English only (no localized-language variants exist).

NB. In order for Oil and Gas functionality to be available, "Eng. Oil & Gas" must be selected in the language menu in the AutoSafe Configuration Tool (Select Language).



4. System Hardware

4.1 System Panels

System Units on AUTROLON		Main Function	Description
Fire Alarm Control Panel  BS-310G (G2*) 320G (G2*) (* SIL2)	BS-310G / 320G is a complete fire alarm control panel with full operating capabilities. The panel serves as a operating panel for one or several defined <i>operation</i> zones. All alarm handling and system features can be controlled and monitored from the panel.	The panel can accommodate up to a maximum of 12 modules. The system offers Loop Driver Modules (maximum 6) for detection loops and several types of I/O modules for monitored outputs, open collector outputs, galvanic isolated inputs and monitored inputs. With a LON interface the control panel can communicate with other system units on the local operating network, AUTROLON. This interface is standard in BS-320G, and not included in BS-310G. Absence of the AUTROLON interface in BS-310G makes it possible to use the BSD-320 interface with this unit. The operator panel is menu operated on a 16 lines display with 40 characters per line. A built-in printer is available. The unit has a 220 VAC / 3A power module for battery charging and a built-in emergency battery.	
Operator Panel  BS-330	The Operator Panel serves as a operating panel for one or several defined <i>operation</i> zones. All alarm handling and system features can be controlled and monitored from this panel.	The panel communicates with Controllers and the entire system via the AUTROLON local operating network. The operator panel is menu operated on a 16 lines display with 40 characters per line. A built-in printer is available. External 24V supply is required.	
Controller  BC-320	The Controller serves as a connection unit for Loop Driver Modules, I/O modules and power supply.	The unit can accommodate up to a maximum of 12 modules. The system offers Loop Driver Modules (maximum 6) for detection loops and several types of I/O modules for monitored outputs, open collector outputs, galvanic isolated inputs and monitored inputs. The unit has a 220 VAC / 3A power module for battery charging and a built-in emergency battery.	
Repeater Panel  BU-320	The panel allows you to operate alarms related to the relevant <i>operation</i> zone.	The panel is used to silence sounders and to reset alarms within a defined operation zone. The whole system can be reset from this panel, provided that the panel's relation to the operation zone is defined this way. The display has space for 16 lines at 40 characters per line and shows detailed information on alarms. External 24 VDC Power is required.	
Information Panel 	The panel serves as an indication device only. It provides	The panel offers buttons for scrolling through events and a button for silencing the internal buzzer.	

System Units on AUTROLON		Main Function	Description
	BV-320	information related to the defined <i>operation</i> zone(s).	The display has space for 16 lines with 40 characters per line and shows detailed information on events. External 24 VDC Power is required.

4.2 AutoFieldBus Driver EAU-341

4.2.1 Description

The AutoFieldBus driver EAU-341 is a communication protocol converter between the AutoSafe IFG panel and the BSD-340 PowerLoop drivers and the BSD-321 RS-485 protocol converters. The EAU-341 provides a redundant field bus system with a ring loop topology.

The AutoSafe panels can have one AutoFieldBus connected, and each AutoFieldBus can host up to 31 bus units.

The AutoFieldBus has short-circuit detection/isolation technology which ensures that only one BSD-340/BSD-321 will be lost in case of internal failure (short-circuit).

The ring loop topology ensures that no detectors/field units will be lost due to a single break or short circuit of the AutoFieldBus cable.

The AutoFieldBus cable is normally 2-wire twisted pair category 5 copper cable, however, fibre optic cable is possible by use of separate signal converters. The AutoFieldBus uses the same guidelines as AUTROLON, in terms of cable lengths, fibre modem and boosters.

The EAU-341 is to be mounted in a subrack in the same rack as AutoSafe or within the AutoSafe cabinet. The interconnecting RS-232 cable between EAU-341 and the IFG panel must be less than 3m.

For further information, refer to data sheet.

4.2.2 Overview

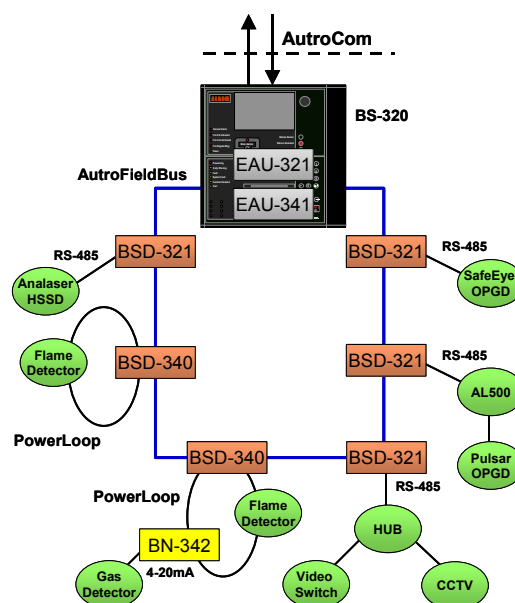

4.2.3 Connections to EAU-341

All connections are made to plug-in screw terminals numbered 1-32.

Terminal	Function
1	AutroFieldBus A
2	AutroFieldBus A'
3	AutroFieldBus CT A
4	AutroFieldBus Earth Fault Sense
9	AutroFieldBus B
10	AutroFieldBus B'
11	AutroFieldBus CT B
12	AutroFieldBus Earth Fault Sense
25	TX RS232 Port 0
26	RX RS232 Port 0
27	Signal Reference Port 0
28	Instrument Earth Port 0
29	+24V Input
30	0V Input
31	Instrument Earth Common
32	Protective Earth Common

All connections not listed in table above must be left unconnected.

4.2.4 Earthing and shielding of EAU-341 and AutroFieldBus

See also "System Shielding and Earthing" chapter 5.6.

EAU-341 power,
Single earth system

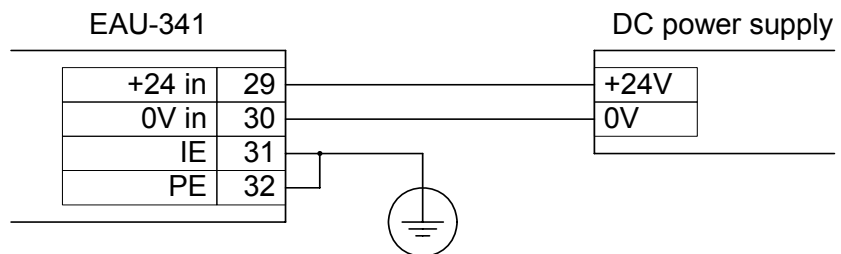

EAU-341 power,
Dual earth system

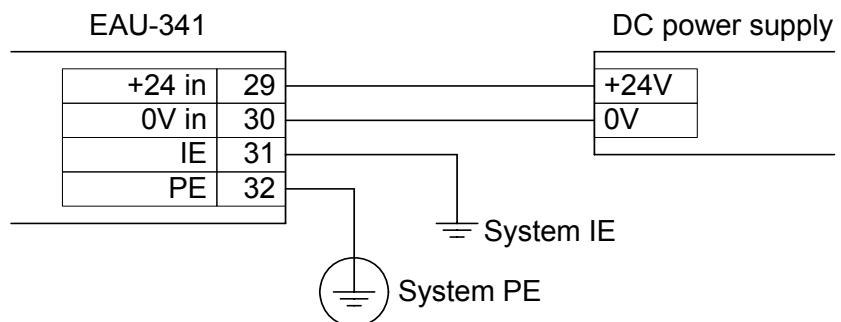

Power and earth connections

If a single earth systems is used both IE and PE must be connected to the earth.

EAU-341 with shielded AFB cable

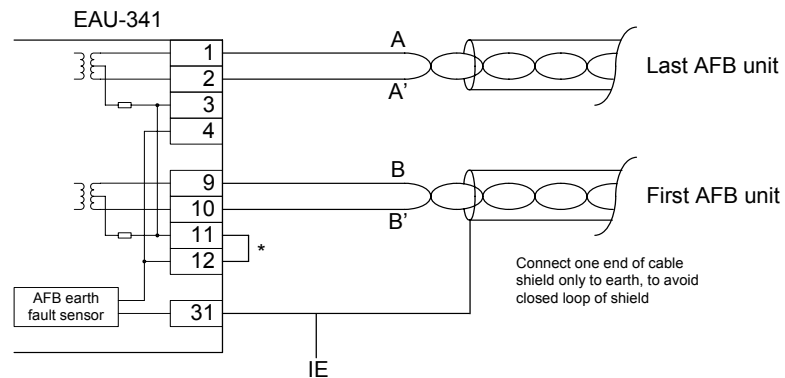

EAU-341 with unshielded AFB cable

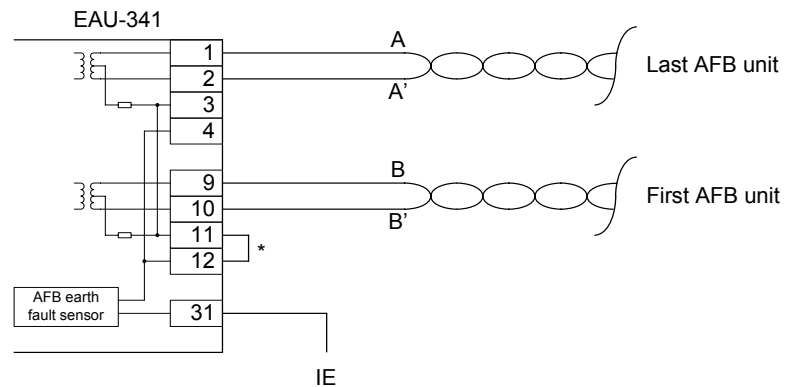

*: Connect if AFB earth fault detection is required. Detection will be done towards the IE terminal (31)
If this link is unconnected, (11) must be connected to IE to reference the AFB.

AutoFieldBus connections

When shielded cable is used on the AutoFieldBus, the shielding should be connected to the instrument earth (IE) at one end and left floating at the other end. If earth fault monitoring on AutoFieldBus is required, connect a wire as described in the figure. All earth fault monitoring is done towards IE in the IFG units.

4.2.5 Connection between EAU-321 and EAU-341

Communication Cable XBA-055 is used between the Serial Communication Board EAU-321 and AutoFieldBus Driver Board EAU-341. An alternative is to use the break-out box (Autronica Fire and Security article no 7366-001.0020)

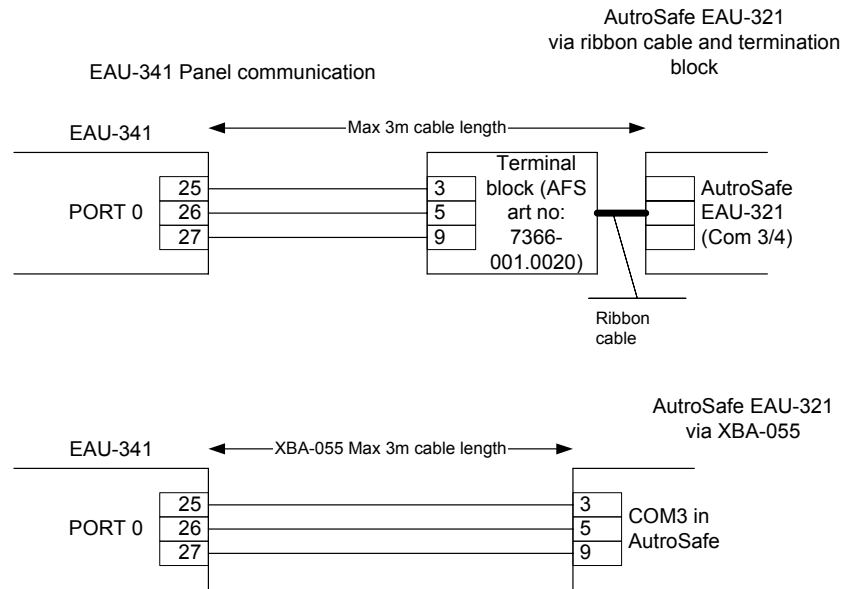

See also datasheets for EAU-321 and EAU-341.

4.2.6 Capacity / Limitations

- If the cable is armoured, this should be connected to the protective earth (PE) at both ends.
- Maximum one EAU-341 can be used for each panel.
- Maximum 31 AutoFieldBus units can be connected to the AutoFieldBus.
- Maximum cable length between the EAU-321 and EAU-341 board is 3m. The cabling must be within the same encapsulation.
- See also datasheet for EAU-341.

4.2.7 Jumper Settings for the EAU-321 board

The table below gives an overview of the jumper settings for the Serial Port Communication Board EAU-321.

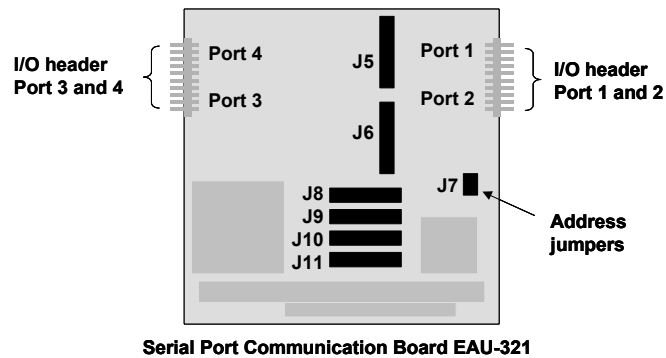

Jumpers J5 and J6:

J5 and J6 must be set to interrupt 2 and 5.

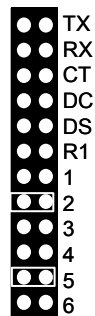

Jumpers J8 (interrupt)

J8 must be set to interrupt 7 and R.



Jumpers J9, J10 and J11 (interrupt)

All ports must be set to interrupt 7.



Jumper J7 (board address)

Jumper in position A and B must be set to In.

This setting applies to all communication boards.

Gives address 100h.



4.3 PowerLoop Driver BSD-340

4.3.1 Description

The *PowerLoop Driver BSD-340* functions as a protocol converter between AutoFieldBus and PowerLoop.

It consists of a PowerLoop interface for power and communication, and an AutoFieldBus interface towards an AutoFieldBus Driver (EAU-341).

The PowerLoop is a two-wire bus capable of delivering 30VDC/ 100W connected in ring topology and is galvanically isolated from the rest of the system. The PowerLoop interfaces detectors and other loop units including a 4-20mA interface.

The BSD-340/1 provides a service port female DSub 9-pin, which is used for commissioning and maintenance.

The AutoFieldBus address is set by switches. The AutoFieldBus is normally category 5 copper cable.

There are three versions:

- BSD-340/1 Rack mounted version
- BSD-340/2 Rail mounted version
- BSD-340Ex

For further information, refer to data sheets.

4.3.2 Overview

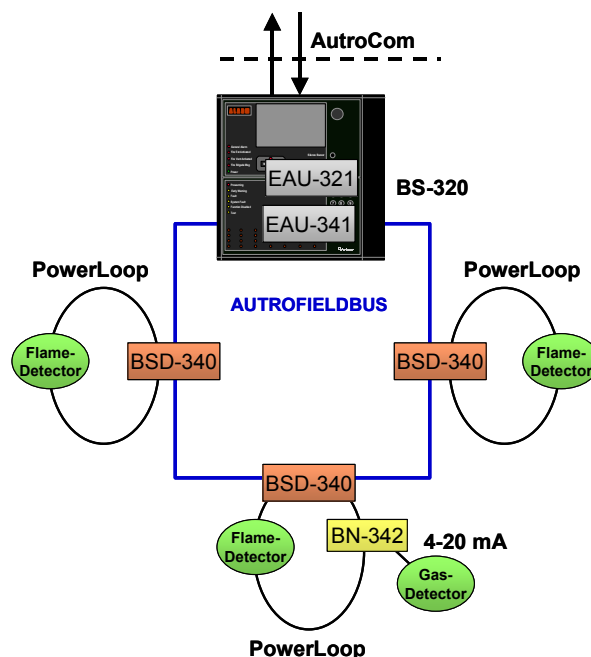

4.3.3 Connections

Note

AutoFieldBus is not polarity-dependent.
PowerLoop is polarity-dependent.

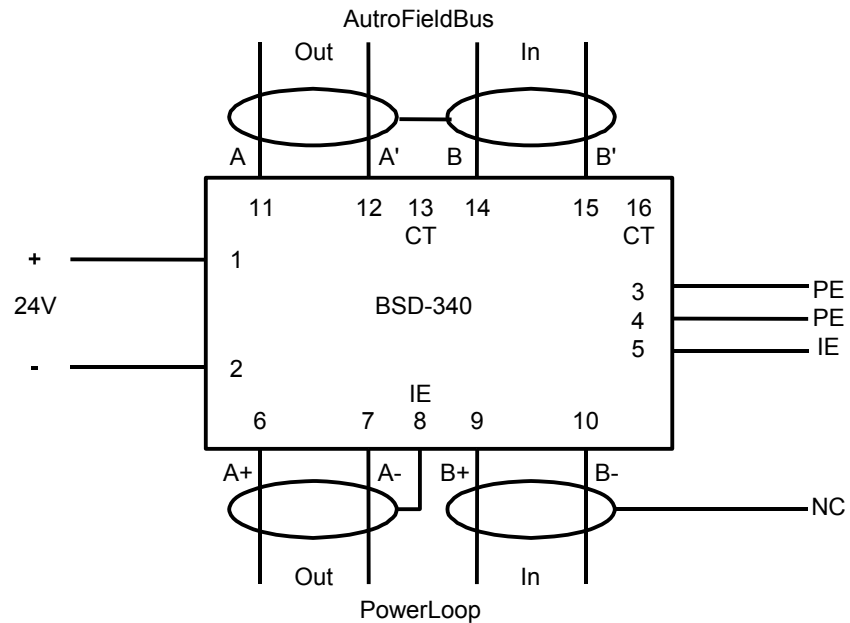

Note: "CT" is used as a reference in case segments of the AFB is left floating when Boosters or Fibre modems are used. This termination is normally left open. See "System Shielding and Earthing" chapter 5.6, for further directions.

4.3.4 Earthing and shielding

If shielded cable is used for the AutoFieldBus, the shielding should be continued around the BSD-340. It could be connected to CT both in and out, see System Shielding and Earthing for reference.

Shielded cable is required for the PowerLoop, and the shielding should be connected to the instrument earth (IE) at one end of the loop. Any armoring should be connected to the protective earth (PE) at multiple points.

4.3.5 Capacity / Limitations

Each PowerLoop must be verified using the PowerLoop Calculator (ConfigTool). Generally, the following applies:

- Maximum 15 detectors can be connected to each PowerLoop.
- May require forced cooling, dissipates up to 30W when fully loaded.
- No branches allowed on PowerLoop or AutoFieldBus.

The total power consumption to PowerLoop units, detectors and cable loss must be verified by the PowerLoop Calculator (part of the AutoSafe Configuration Tool).

- See also datasheet for BSD-340.

4.4 PowerLoop 4-20 mA Input Unit BN-342

4.4.1 Description

The *PowerLoop 4-20mA Input Unit BN-342* is a general purpose PowerLoop interface designed for third party detectors connected to the AutoSafe Integrated Fire and Gas System.

The PowerLoop is a two-wire power and signalling bus connected in ring topology and is galvanically isolated from the rest of the system.

The unit communicates with AutoSafe using the PowerLoop protocol. The unit has a 4-20mA input galvanically isolated from the PowerLoop.

For further information, refer to data sheets.

4.4.2 Versions

- BN-342/EX*: EEx me version including 9,5W DC/DC for external detector power supply
- BN-342/1: 19" 3U rack version, bare PCB with 19" rack front panel, no DC output
- BN-342/2*: DIN rail version, bare PCB in a open DIN rail box, no DC output

* See next chapter.

4.4.3 Options selected in AutoSafe Configuration Tool

The configuration of the options is described in detail in the Help file integrated into the AutoSafe Configuration Tool.

- Simrad GD-10P Interface
- Sieger Excel OPGD*
- Sieger Excel Duct*
- Dräger XP Tox
- General purpose 4-20 mA unit (configured in AutoSafe Configuration Tool)

* Sensor-power must be supplied from an external source.

- See also datasheet for BN-342.

4.4.4 Overview

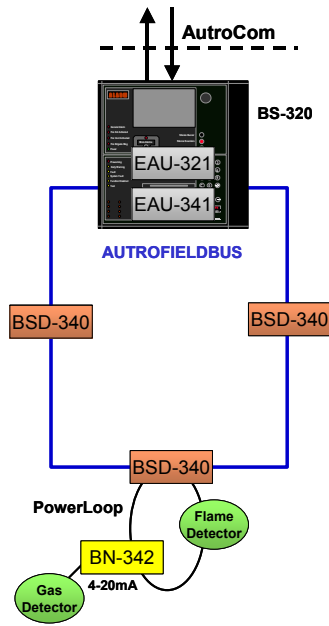

4.4.5 Connections

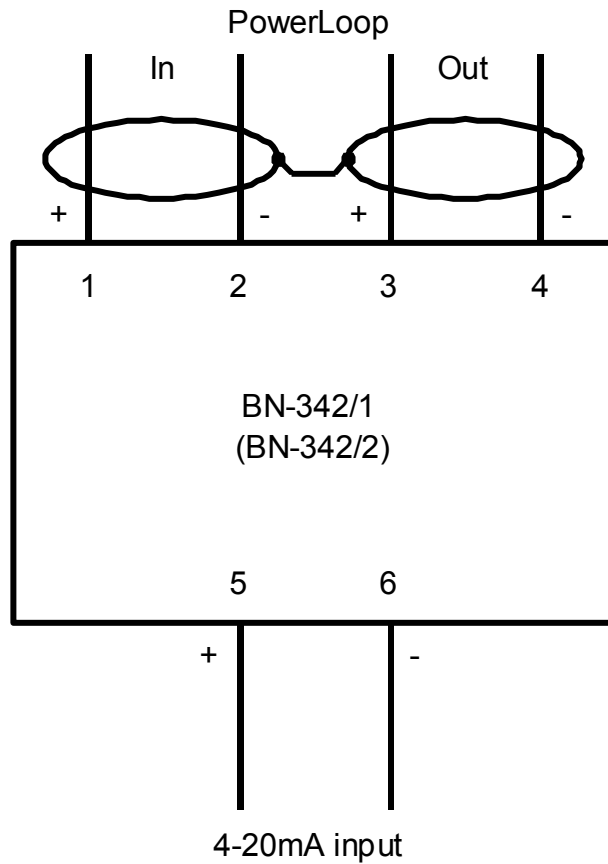

If shielded cable is used for the PowerLoop, the shield should be continued.

4.4.6 Connection – current source

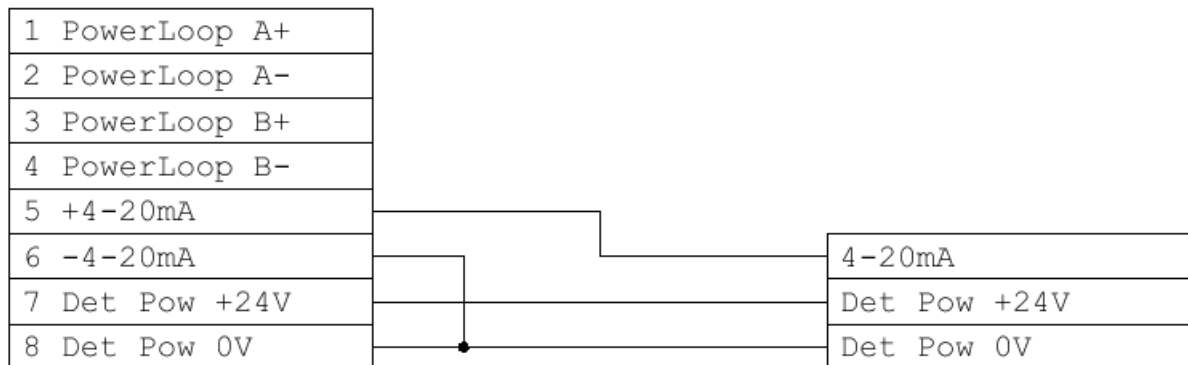

4.4.7 Connection – current sink

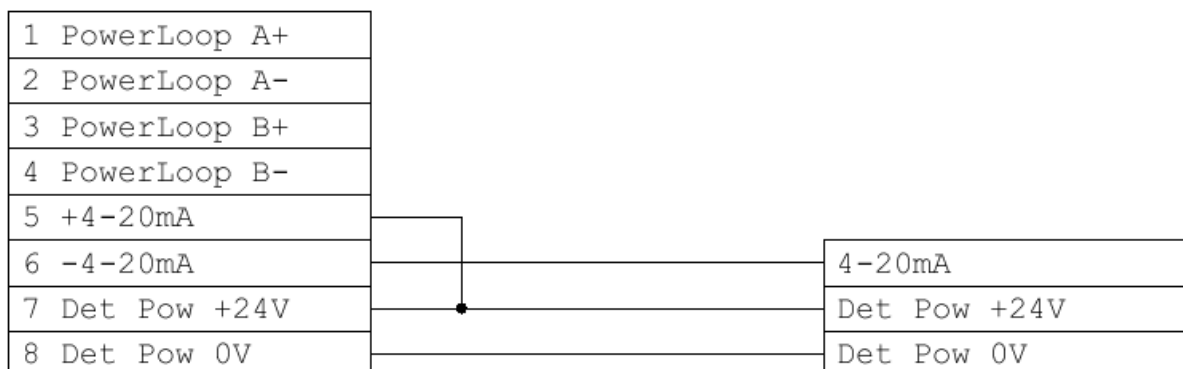

4.5 PowerLoop 4-20 mA Input Unit BN-342/EX

4.5.1 Description

The *PowerLoop 4-20mA Input Unit BN-342/EX* is a general purpose PowerLoop interface designed for third party detectors connected to the AutoSafe Interactive Fire Alarm System.

The PowerLoop is a two-wire bus capable of delivering 30VDC/100W connected in ring topology and is galvanically isolated from the rest of the system.

The unit communicates with AutoSafe using the PowerLoop protocol from BSD-340 Loop Driver.

The unit has a 24VDC/9,5W output providing power to the connected detectors, plus a 4-20mA input galvanically isolated from the PowerLoop.

4.5.2 Versions

- BN-342/EX*: EEx me version including 9,5W DC/DC for external detector power supply
- BN-342/1: 19" 3U rack version, bare PCB with 19" rack front panel, no DC output
- BN-342/2*: DIN rail version, bare PCB in a open DIN rail box, no DC output

4.5.3 Overview

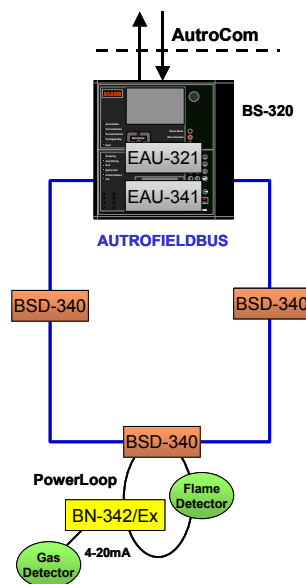

4.5.4 Connections

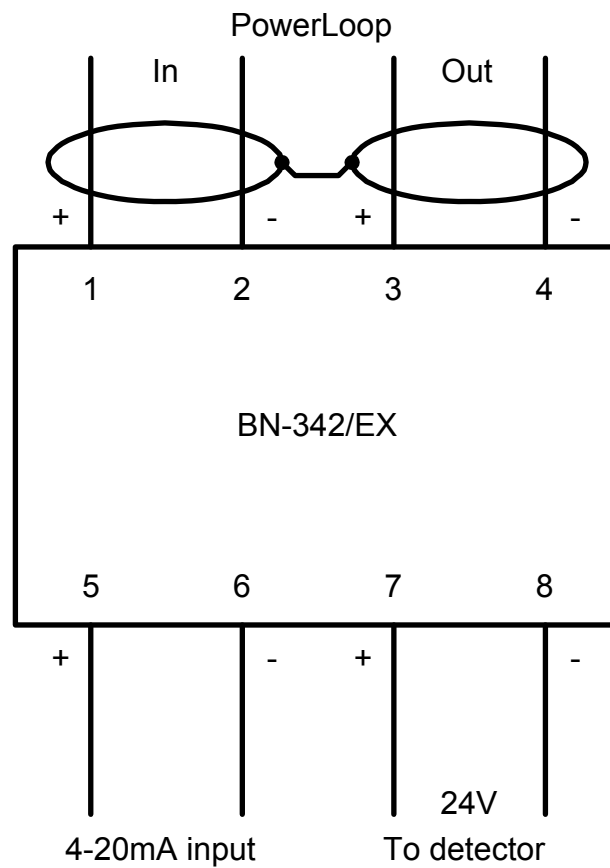

4.5.5 Earthing

If shielded cable is used on the PowerLoop, the shield should be continued. Separate terminals are available.

- See also datasheet for BN-342/EX.

4.6 AutoFlame Multispectrum Flame Detector X33/1 PL

4.6.1 Description



The *AutoFlame Multispectrum Flame Detector X33/1 PL* utilises advanced signal processing algorithms, supported by an embedded 32-bit microprocessor, to provide continuous protection in the presence of false alarm sources and environments with infrared radiation present.

The detector has built-in PowerLoop technology which makes the detector capable of being powered and communicating with AutoSafe Integrated Fire and Gas panels (IFG) on the same pair of wire, saving cable cost and weight. Each detector has a built-in short circuit isolator, hence no detectors will be lost because of a single break or short circuit in the PowerLoop lines.

All alarms and faults, like dirty optics and temperature out of range, will be signalled via PowerLoop.

The PowerLoop is a two-wire power and signalling bus connected in ring topology and is galvanically isolated from the rest of the system.

The detector does not require any local power supply.

The detector has a detection range to gasoline of over 60m, and a solid cone of vision for methane.

For further information, refer to data sheet.

4.6.2 Applications

The detector is suitable for applications that are at the extremes, and where background infrared radiation is a normal condition (Offshore production platforms, Offshore production ships, Refineries, Production facilities, Loading racks, Compressor stations, Turbine enclosures).

4.6.3 Connections

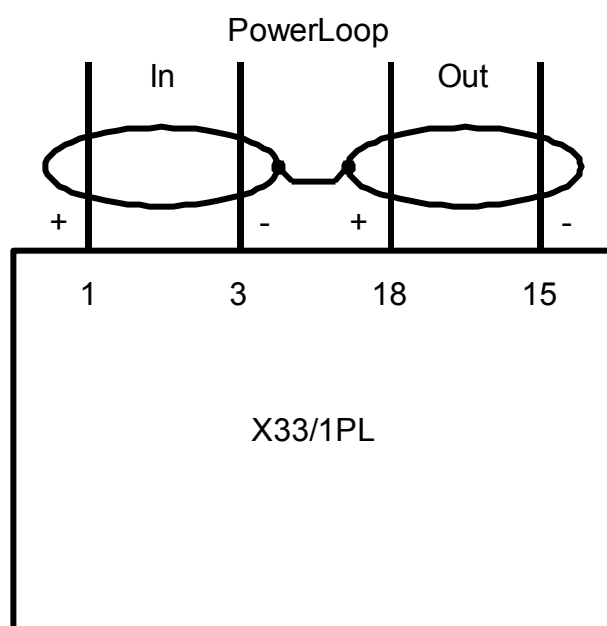

Shielded cable is required for the PowerLoop, the shielding should be continued.

4.7 AutoPoint Gas Detector HC300 PL

The AutoPoint HC300 PL is a diffusion-based, infrared combustible gas detector that provides continuous, fixed monitoring of flammable hydrocarbon gases in concentrations from 0 to 100% Lower Explosive Limit (LEL).

Ideally suited for protection of challenging on/offshore oil and gas facilities and other downstream hydrocarbon applications, the AutoPoint HC300 PL is certified for use in hazardous areas Zone 1 and Zone 2. In addition, the stainless steel construction, sapphire optics, and modular design all combine to deliver industrial grade hardness along with easy installation and the lowest cost of ownership available.

The AutoPoint HC300 PL is capable of detecting hundreds of flammable hydrocarbon vapours. Field-selectable algorithms are provided for methane (default), ethane, propane, butane, ethylene, and propylene. Numerous additional operating parameters are programmable via an optional hand-held communicator.

The detector has a built-in PowerLoop technology which allows the detector to be powered and communicate with AutoSafe Integrated Fire and Gas panels (IFG) on the same pair wire, saving cable cost and weight. Each detector has a built-in short-circuit isolator, hence no detectors will be lost because of a single break or short-circuit in the PowerLoop lines.

All alarms and faults, like dirty optics and temperature out of range, will be signalled via the PowerLoop.

The PowerLoop is a two-wire power and signalling bus connected in a ring topology and galvanically isolated from the rest of the system.

The detector does not require any local power supply.

- See handbook for detector HC300 PL regarding calibration and additional information.

4.7.1 Connections

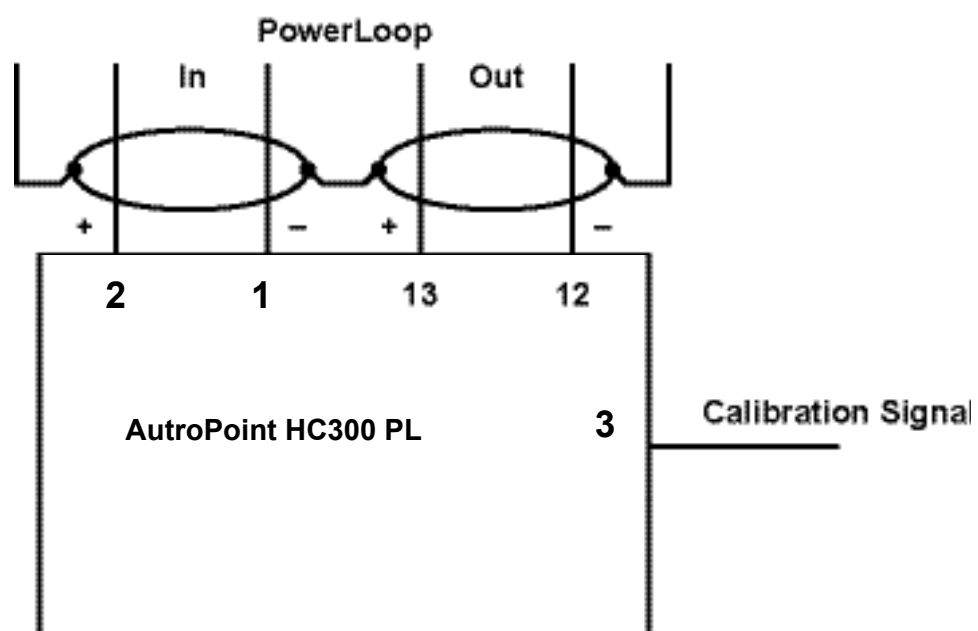

Shielded cable is required for the PowerLoop, the shielding should be continued.

4.8 AutoFieldBus Protocol Converter BSD-321

4.8.1 Description

BSD-321 functions as a protocol converter between AutoFieldBus and various detectors communicating on RS-485.

It consists of a serial interface for detector communication and an AutoFieldBus interface to an AutoFieldBus driver (EAU-341).

BSD-321 provides a service port, MTA-style, used for service and maintenance.

The AutoFieldBus address and desired protocol are set using rotary switches. The AutoFieldBus is normally made up of Category 5 copper cable.

BSD-321 is produced to mount on a DIN TS-35 rail.

For further information, refer to datasheet for BSD-321.

4.8.2 Overview

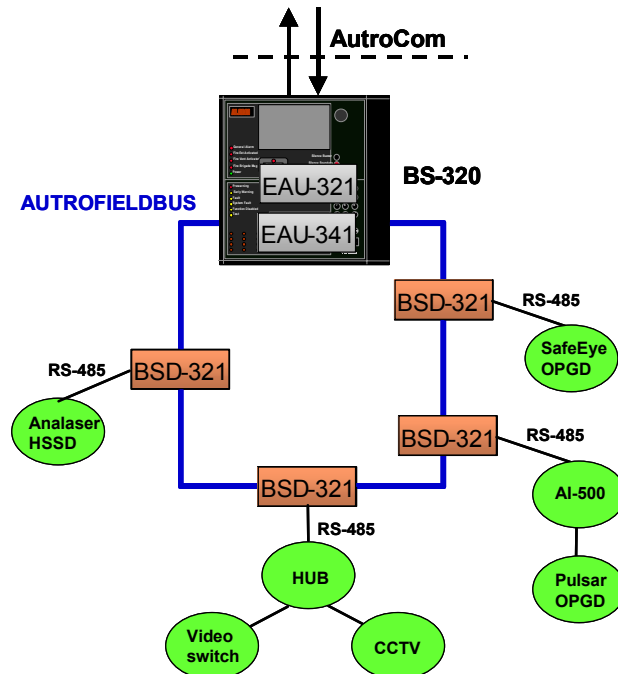

4.8.3 Connections

All connections are made to plug-in screw terminals numbered 1-32.

Terminal	Function
1	AutroFieldBus A
2	AutroFieldBus A'
3	AutroFieldBus CT A
4	AutroFieldBus Earth Fault Sense
5	RX RS422_A+ Port 1
6	RX RS422_B- Port 1
7	TX RS422_X+ Port 1
8	TX RS422_Z- Port 1
9	AutroFieldBus B
10	AutroFieldBus B'
11	AutroFieldBus CT B
12	AutroFieldBus Earth Fault Sense
13	TX RS232 Port 1
14	RX RS232 Port 1
15	Signal Reference Port 1
16	Instrument Earth Port 1
17	RX RS422_A+ Port 0
18	RX RS422_B- Port 0
19	TX RS422_X+ Port 0
20	TX RS422_Z- Port 0
21	TX RS232 Service port
22	RX RS232 Service port
23	RS232 Service port Signal Reference
24	No connection
25	TX RS232 Port 0
26	RX RS232 Port 0
27	Signal Reference Port 0
28	Instrument Earth Port 0
29	+24V Input
30	0V Input
31	Instrument Earth Common
32	Protective Earth Common

AFB cable with continuous shield

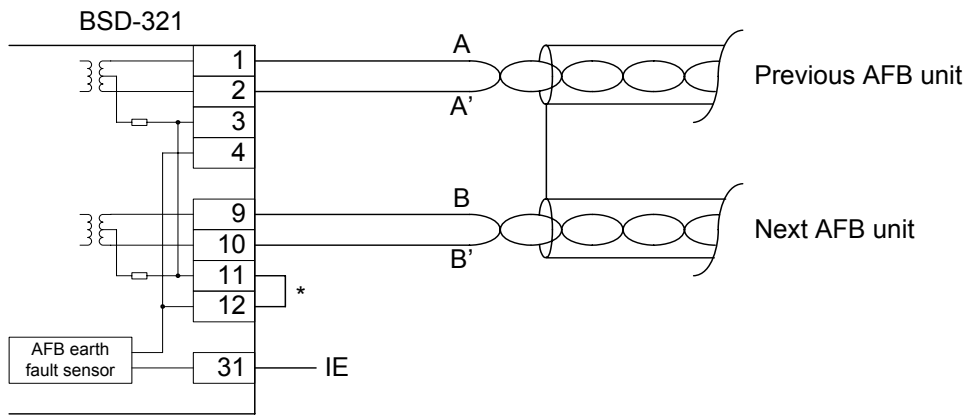

AFB cable with discontinuous shield

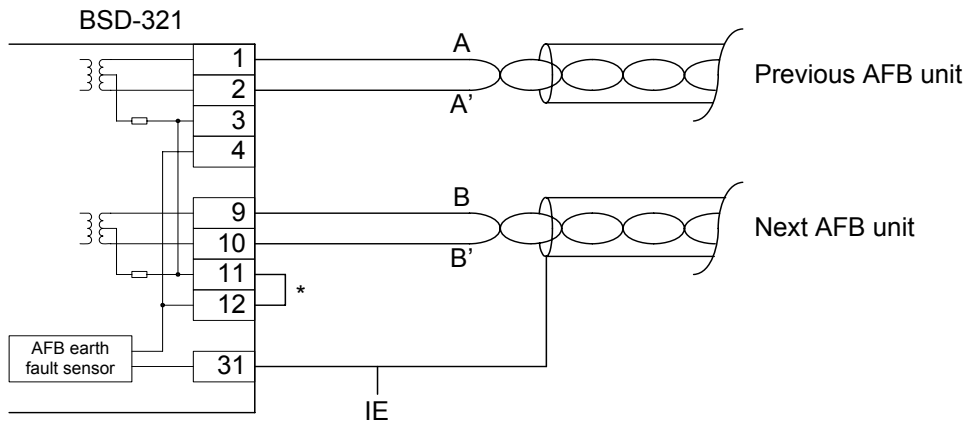

AFB cable without shield

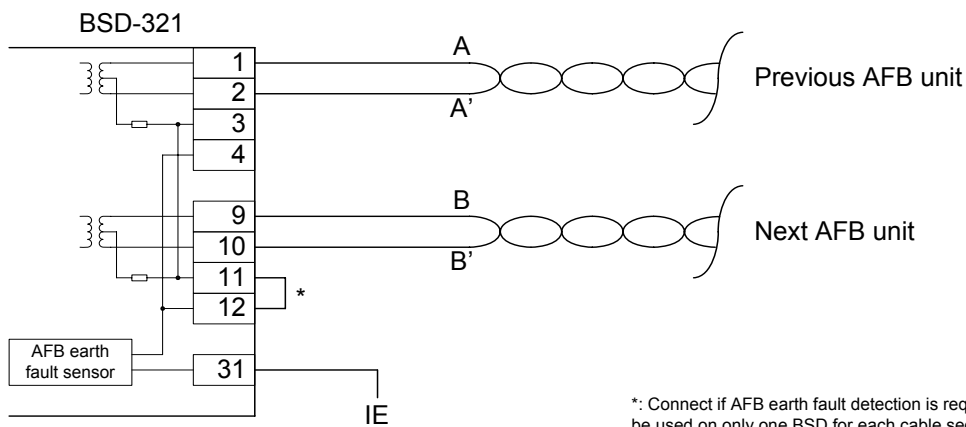

*: Connect if AFB earth fault detection is required. This feature should be used on only one BSD for each cable segment. Detection will be done towards the IE terminal (31)

4.8.3.1 Power supply connections

The BSD-321 is intended for use with 24VDC power supplies. It may be used in single or dual earth systems.

BSD-321 power,
Single earth system

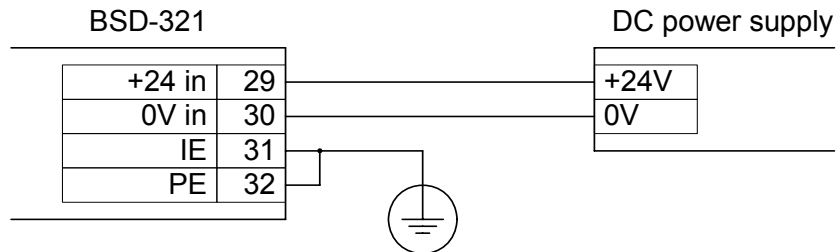

BSD-321 power,
Dual earth system

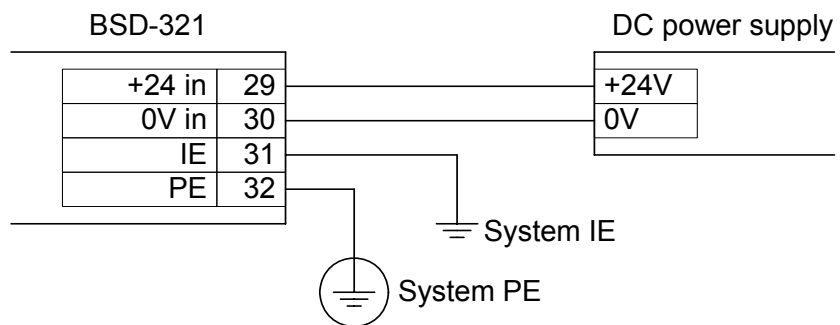

4.8.3.2 Obtaining RS-485 using the BSD-321 RS-422 connections

RS-485 is obtained by connecting the BSD-321 RS-422 ports in RS-485 mode. This is done by connecting the A and the X signal together, and the B and the Y signal. The resulting RS-485 signal names will be A and B.

4.8.3.3 RS-485 Detector interface

RS-485 branch connection (local loop-back):

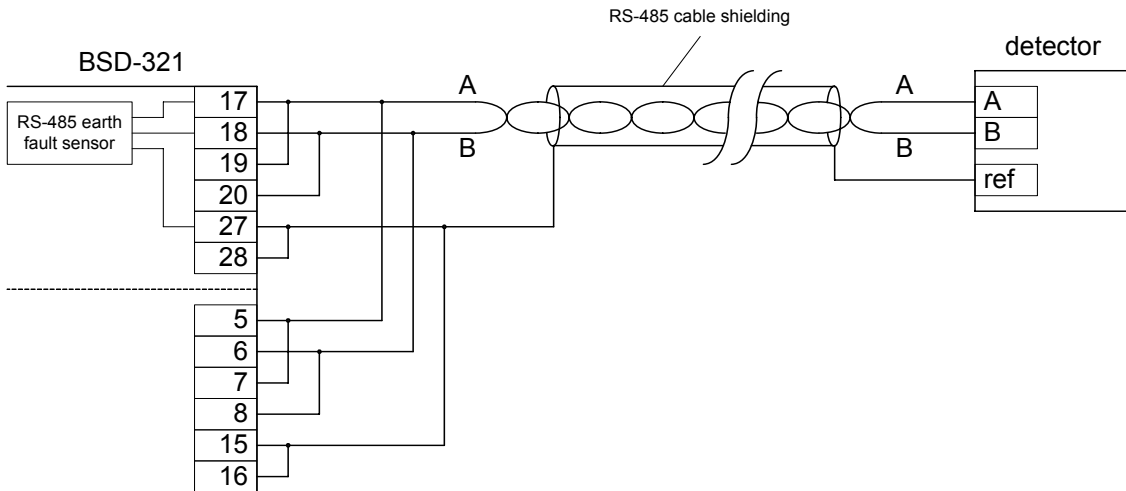

RS-485 loop connection (remote loop-back):

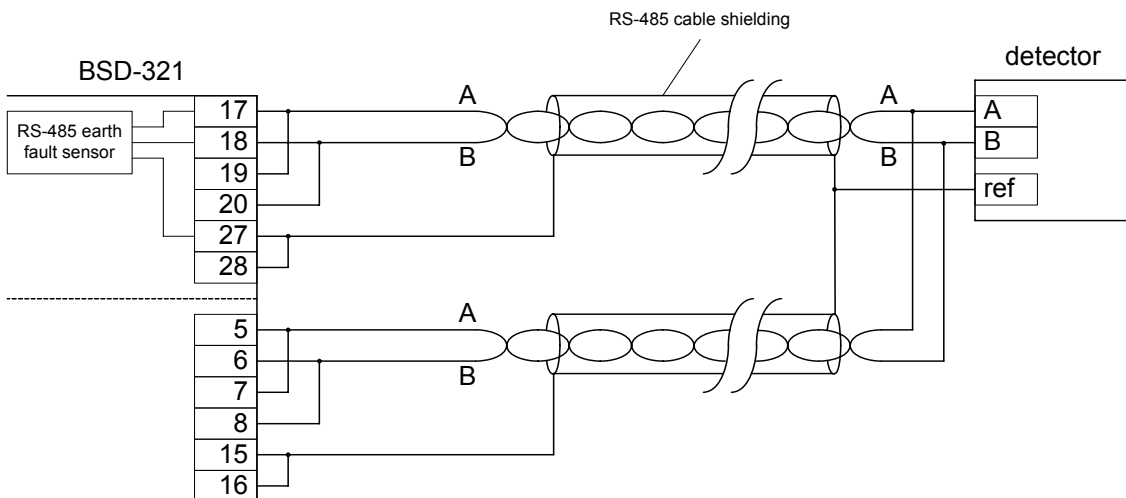

4.8.3.4 The "ref" signal on the detector:

The ref signal on the detector is the detectors "common" signal for the RS-485.

This signal may be connected to IE (or earth in single earth systems), to the detectors power supply 0V or it may be isolated (floating). All detectors on the same RS-485 bus must have the same reference. It is essential the connection to the RS-485 shield is done only in one point in the system if the detectors are not 100% isolated from each other (individual isolated detector power supplies and no earth reference).

Also refer chapter 4.8.4 and 4.8.5 for more details.

4.8.3.5 Why loop-back?

The BSD-321 requires a RS-485 loop-back connection. Loop-back is used to give increased system safety. While one channel on the BSD-321 is transmitting, the other is receiving making it possible to verify that the internal operation of the BSD-321 is correct. By using RS-485 loop connection dual communication paths to the detectors are obtained in addition.

Loop-back

Loop-back of RS-485 can be done either locally on BSD-321 or remotely with loop to/from detector. Switches S1 and S2 must be set accordingly for correct termination.

Local loop-back:

- Set S2-6 OFF (Disable EOL resistor for port 1)
- The detector at the other end of the RS-485 bus must enable its EOL resistor

Remote loop-back:

- Set S2-6 ON (Enable EOL resistor for port 1). None of the detectors must have EOL resistors

4.8.4 Earthing

If shielded cable is used for the AutoFieldBus, the shield should be connected to the CT terminals (both in and out, terminals 3 and 11).

Shielded cable is required used for the RS485 cable, the shielding should be connected to the instrument earth (IE) for serial 0 or serial 1, respectively.

Any armouring should be connected to protective earth (PE).

See "System shielding and earthing" for further information.

4.8.5 Typical applications using different signal references

Application 1

The schematic drawing below shows an application where the reference is tied to the local earth. The cable shield is terminated at the BSD-321 end only.

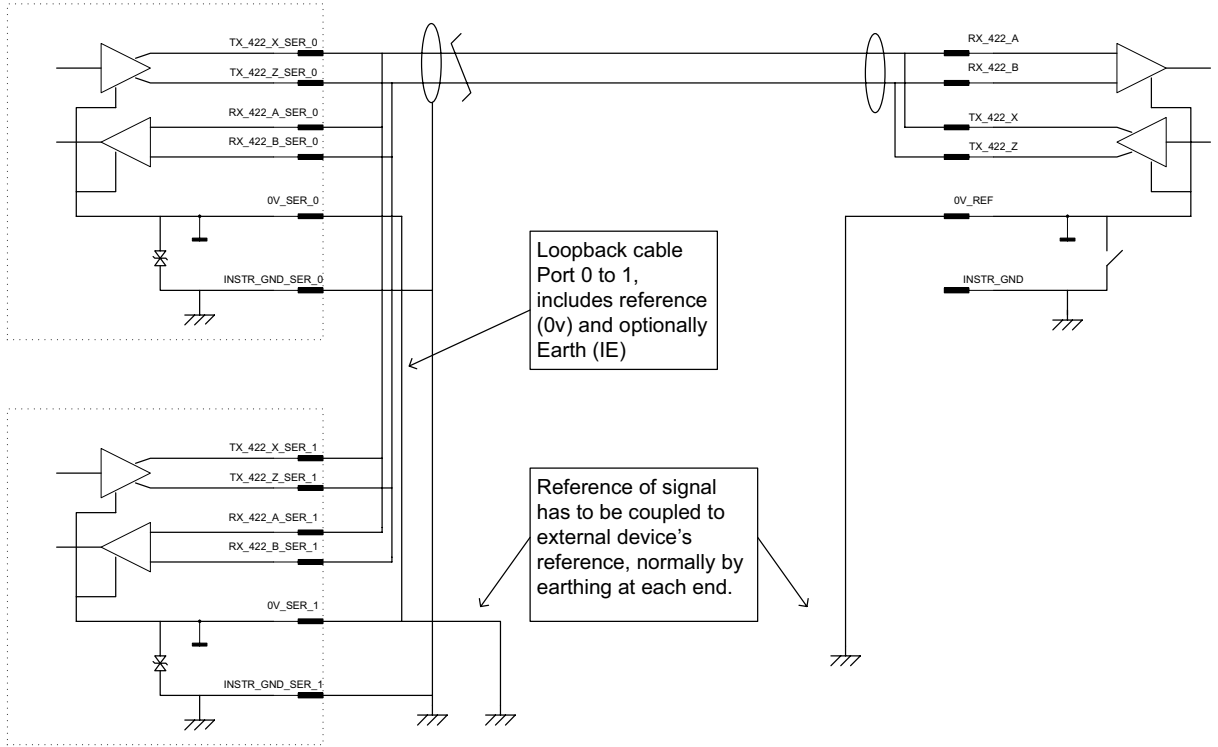

Application 2

The schematic drawing below shows an application where the reference is coupled to the detector's reference. The RS-485 connection is floating at the BSD-321 side. The cable shield is terminated at the BSD-321 end only.

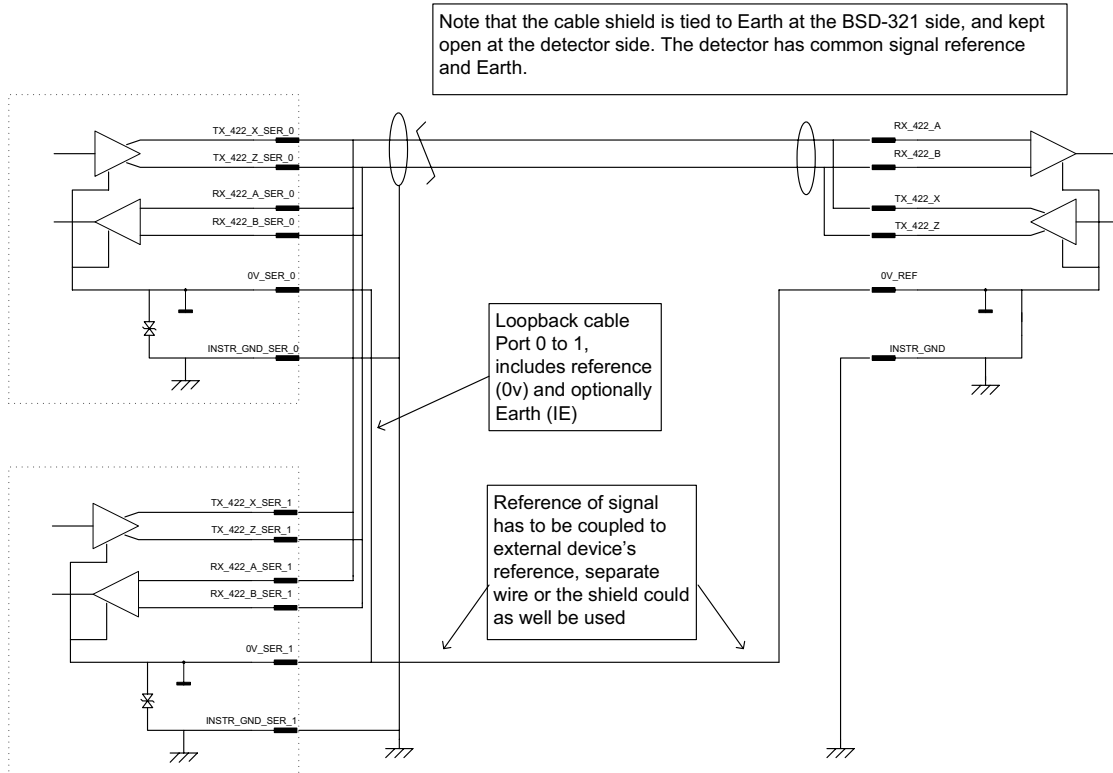

Application 3

The schematic drawing below shows an application where the detector has common signal reference and Earth. The shield and signal reference is tied together at the same location by the detector only (the IE point at the ports are floating).

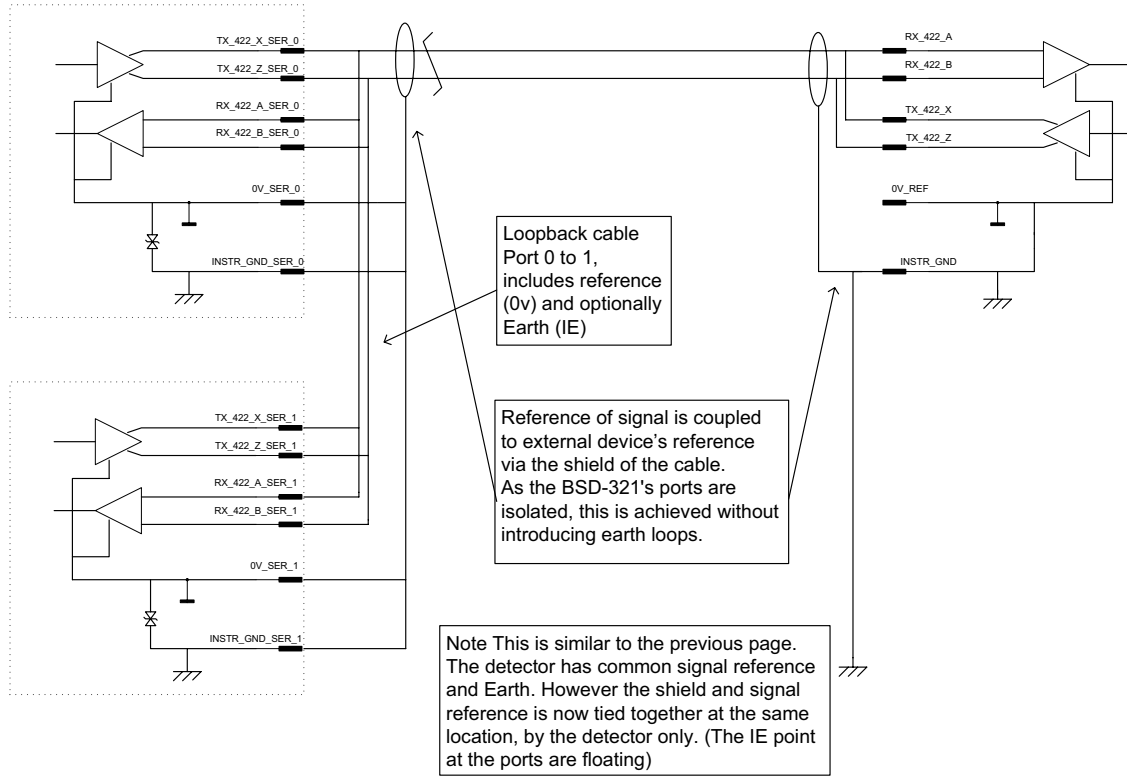

4.8.6 Port Isolation on RS-422 ports

The schematic drawings show the RS-422 ports on the BSD-321.

Each port is isolated from the rest of the electronics on the BSD-321 and has separate Instrument Earth per port.

The signal reference of the driver / receiver is separated from Earth.

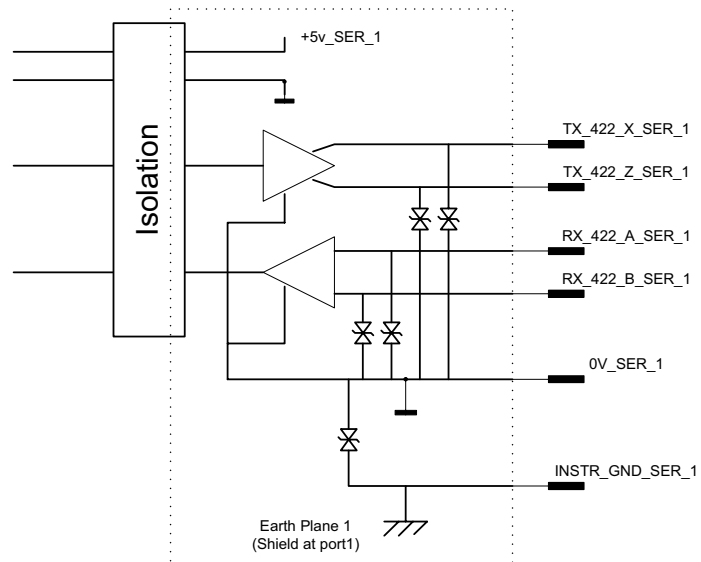
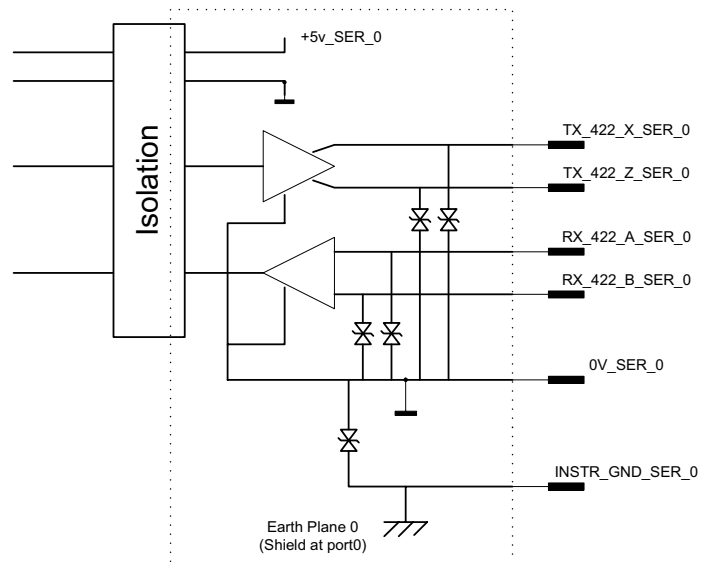

5. Projecting Guidelines

5.1 General Recommendations / Planning

- Bear in mind future expansions when choosing cable dimensions, especially with regard to the PowerLoop. See *Cable data* on the next page and *Cable Specifications* in the System Specification Handbook, 116-P-ASAFE/XE.
- Make sure that the PowerLoop is disabled during installation, service and maintenance.
- No branches are allowed on the PowerLoop or AutoFieldBus.
- Make sure that the detectors are evenly distributed on the available loop drivers. This provides the best possible load sharing and allows sufficient headroom for future expansion.
- Always use the PowerLoop Calculator to verify the installation before commissioning.

5.2 Technical Overview

5.2.1 Limitations - Panels and Loop Units

Maximum number of Panels	A maximum of 32 panels can be networked.
Maximum distance between panels	1000; 2800m with booster (BSL-325); 3000m between each panel with fibre-optic link.
Maximum number of AI_Com detection per panel	6 (EX as individual offshoot of normal loop).
Maximum number of Loop Units	A maximum of 512 detectors can be connected to each panel. This includes all types of detectors; gas detectors, flame detectors, heat detectors, smoke detectors, manual callpoints etc.
Maximum number of AutoFieldBus Drivers per panel	1 (EAU-341)

5.2.2 Loop data

Loop driver types	BSD-310: Standard detection loops for AutoSafe addressable loop units (EX support with Zener Barrier BZ-500)
	BSD-311: High-power version of BSD-310, for loops consuming more than 140mA
	EAU-341 AutoFieldBus driver
	BSD-321: AutoFieldBus loops (RS-485 interface)
	BSD-340: PowerLoop
Maximum number of loop units per AI_Com detection loop	127 (of which 99 can be detectors)
Maximum number of loop units per AutoFieldBus	Up to 31 PowerLoop drivers or Protocol Converters (or a combination of these)
Maximum number of loop units per PowerLoop	Up to 15 addressable gas or flame detectors, or 4-20mA interface units.

5.2.3 Cable data

Standard loops	Recommended cable: Screened cable; maximum loop resistance 50Ω, CSA 1.0mm ² .		
PowerLoop	Recommended cable: Screened cable; maximum loop resistance depends on load; CSA 1.5-2,5mm ² . Larger installations may require up to 10mm ² . The maximum cable length is 1000m.		
Communications	Recommended cable: CAT5		
Loops - Maximum length	Maximum resistance / capacitance	Cable dimensions	Length
	50Ω / 0,5μF	2 x 0,75 18	1000m
		2 x 1,5 15	2000m
		2 x 2,5 13	3300m
N. B. The maximum resistance on the total cable length (+ and – conductors) is 50Ω.			

AUTROLON

The recommended cable type on the AUTROLON is Category 4 or 5 cable, for example, ABB art. no 10892 30 "CAT.5 UTP 4x2/0.5mm² DATAKAB.

AutroFieldBus

The AutroFieldBus cable is normally 2-wire twisted pair category 5 copper cable, however, fibre optic cable is possible by use of separate signal converters. The AutroFieldBus uses the same guidelines as AUTROLON, in terms of cable lengths, fibre modem and boosters.

PowerLoop

Must be shielded. Max length 1000m. Each powerLoop needs to be shielded separately. Parallell paths of powerloop cables may introduce crosstalk between different loops. Avoid this by separating possible parallel paths. Dual shielding or shielding barriers should be used in this case to minimise crosstalk.

5.2.4 Connectivity

AutoCOM	AutoCOM-compliant devices; AutoSafe devices.
Modbus	Provides connectivity with programmable logic systems for ventilation, process-control and distributed control systems.
ProfiBus/ProfiSafe	Provides SIL2-approved connectivity with programmable logic systems for ventilation, process-control and distributed control systems.

5.2.5 Power Supply data

Power supply (AutoSafe loop units)	Via detection loop
Power supply (PowerLoop loop units)	Via PowerLoop
Power supply (AutoFieldBus & 4-20mA)	External power supply, from localized sources, or on independent loop following loop.

5.3 Typical System Configurations - Examples

Modular design allows AutoSafe to be adapted to different applications and systems. The tables below are examples with a number of panels and various detectors for typical system configurations, including:

- Floating production, storage and offloading system
- Offshore platform systems
- Land-based petrochemical system

5.3.1 Floating production, storage and offloading system

Panels	2
Smoke detectors	235 45 EX
Heat detectors	30
Manual call-points	40
Flame detectors	80 10 CCTV
Point gas-detectors	60
Open-path gas-detectors	40

5.3.2 Offshore platform systems

Panels	4
Smoke detectors	390 168 EX
Heat detectors	28
Manual call-points	117
Flame detectors	106
Point gas-detectors	155
Open-path gas-detectors	67
Toxic-gas (H ₂ S) detector	24

5.3.3 Land-based petrochemical system

Panels	4
Smoke detectors	390 168 EX
Heat detectors	28
Manual call-points	117
Flame detectors	106
Point gas-detectors	155
Open-path gas-detectors	67

5.4 Mounting

For detailed information on the mounting of drivers, units and detectors for IFG, please refer to the chapter System Hardware in this handbook or the available data sheets.

The data sheets also include information on dimensions, connections/screw terminals, switch settings and LED-information.

5.5 Configuration

The configuration of all functionality related to AutoSafe Integrated Fire & Gas is described in the HTML Help System. The HTML Help System is an integrated part of the AutoSafe Configuration Tool.

5.6 System Shielding and Earthing

5.6.1 Introduction

The AutoSafe Integrated Fire and Gas System (IFG) has been designed to supply power and communications to advanced flame and gas detectors. The system is able to deliver up to 100W of power and uses a digital communications system, which modulates the PowerLoop at approximately 130kHz.

The PowerLoop system also allows hundreds of metres of cable to be used between the loop driver and the field equipment.

The PowerLoop concept provides the user with a potentially powerful radio transmitter and an excellent antenna. It is therefore vitally important that adequate precautions are taken to screen the signals from such an arrangement to avoid crosstalk between similar PowerLoops and also to keep the system operating within the prescribed Electromagnetic Compatibility (EMC) limits.

This chapter deals with rules and limitations for PowerLoop installations.

5.6.2 Definitions

Local Frame Earth The electrical connection to the framework at the described physical position, such as the frame or chassis of a cabinet, the power cable outlet etc.

Shield Conductive structure encapsulating the wire in a harness or cable, normally in the form of a mesh or foil forming a Faraday cage.

Armour Mechanical protection to avoid physically damaging electrical cables or circuits.

Instrument Earth (IE) An earth reference that is normally used to reference measurements of electrical signals. It may be the same as the Protective Earth (single earthed systems).

Protective Earth (PE) An earth reference that is normally used as a coupling path for unwanted electrical signals, like transients and over-voltage. The chassis or framework of the installation is normally considered to be the local Protective Earth. As the name implies, it is intended to provide a safe electrical potential for human safety.

Ground Synonym for Earth, in this handbook Earth is used.

5.6.3 Single Earth Systems – Power Loop

Firstly, consider a Single Earth system for simplicity.

- 1) All PowerLoop cabling must be shielded

Every segment of the PowerLoop cable has to be protected by a shield that effectively attenuates the radiated field from the cable.

The shielding is required to avoid radiated emissions and hence crosstalk from one PowerLoop to any other. Armouring is normally not considered to be a sufficient shield.

- 2) Shield must be terminated at one end only

The shield must be terminated close to the BSD-340 PowerLoop Driver. As the cable forms a full loop, the return path of the cable shield must not be terminated. No electrical connection to earth must be made anywhere in the system, i.e. the units must be installed and galvanically isolated from the chassis.

The termination of the shield will be defined by the site installation, to a earth terminal in the cabinet or similar.

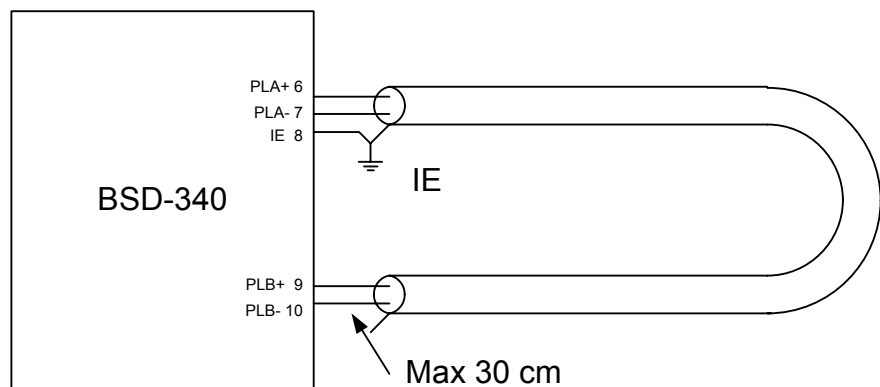

- 3) Maximum permissible non-shielded length of cable - 30 cm

This implies that the internal cabling in a rack or enclosure where the BSD-340 and / or the Loop Units are installed also needs to be fully shielded. The requirement includes termination / junction boxes and all field wiring as well.

4) Shield must be continuous

The PowerLoop cable will be split in two segments, separated by field equipment including junction boxes or Loop Units. The shield must be continued through these separations. There must be no electrical connection to the local frame earth.

In the following figure the junction boxes includes a strap / jumper to continue the shield between the cable segments (these straps / jumpers should be made of a suitable low-impedance cable).

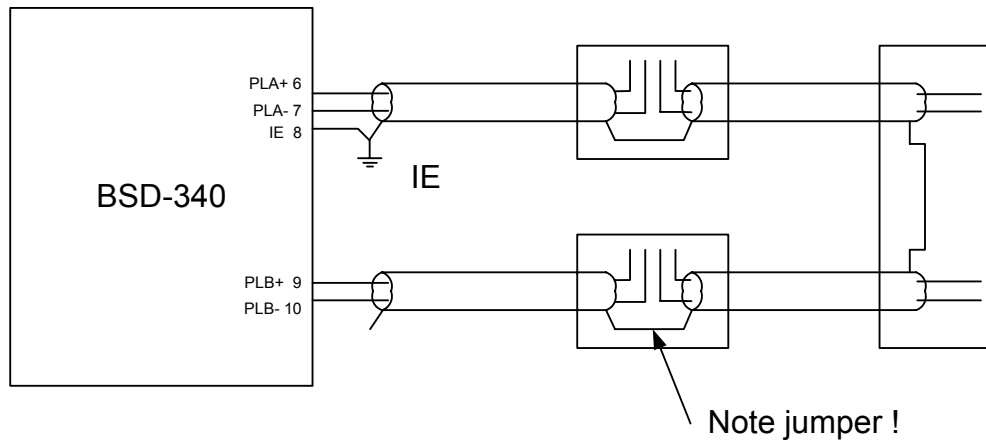

If there are break-outs from the main loop (to make local small loops that return to the same break-out box), care must be taken to avoid local closed loops. See the figure below.

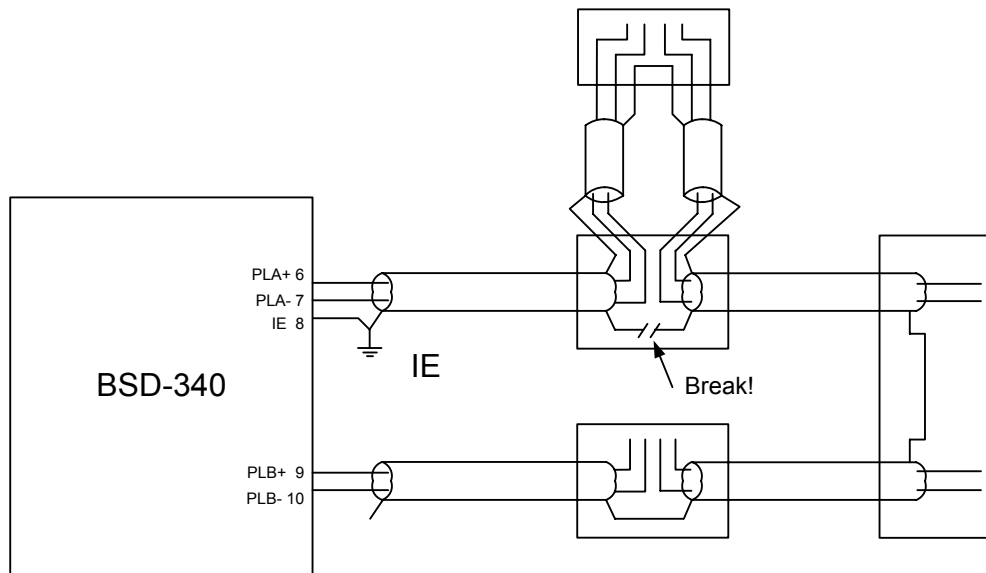

5) Maximum cable length

The PowerLoop Calculator will define the maximum length of each cable segment, this tool however determines length only from the power loss of the specified cable. The cable or wire capacitance will not affect the cable length as much as the resistive loss will restrict the power, not the communication.

5.6.4 Dual Earth Systems – Power Loop

Some installations use both Instrument Earth (IE) and Protective Earth (PE) as two separate earthing paths. In this case, the shield (inner layer of cable) must be continuous and earthed at one end only. The outer braid, shield or armour, is then connected to the Protective Earth connection. This will normally be the local connection point to the PE, the chassis of the cabinet or a chassis connection close to the field equipment. The two earth systems must be isolated.

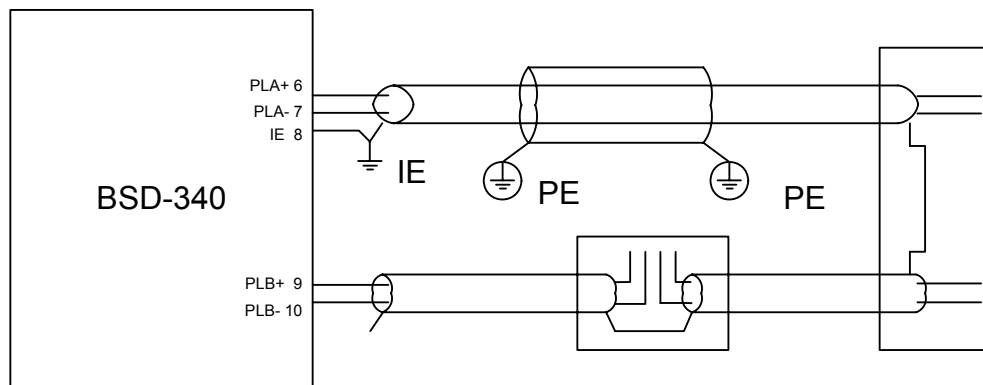

PE will make earth loops as they are terminated at multiple points, however the loop area will be narrow or closed as the armour will be close to the frame or earth. It is essential that the armour is kept on the same equipotential around to avoid EMC problems or large current flow in the PE. PE may be connected through glands to the junction boxes to form a continued protective armour or shield. Still the internal shield and IE must be kept isolated from the PE.

5.6.5 Shielding & Earthing AutoFieldBus

Each unit that may be connected to AutoFieldBus has described the local earthing requirements in their datasheet.

In the total system overview, some key issues needs to be taken care of:

- There are no absolute requirements for shielding, however if severe electromagnetic interference is expected, shielding should be applied.
- If shielded cable is used, it should be continuous. Care should be taken to avoid earth/shield loops. As a guideline, connect the shield to the B-side of the EAU-341 and not to the A-side (as shown in the figure, chapter 4.2.4)
- If segments of the AutoFieldbus cable is isolated, as it will be when including BSL-325 Booster, BSL-321 Multimode Fiber or BSL-322 Single Mode Fiber, local earthing of the isolated segments is required. See figure for example. We follow the cabling counter-clockwise:

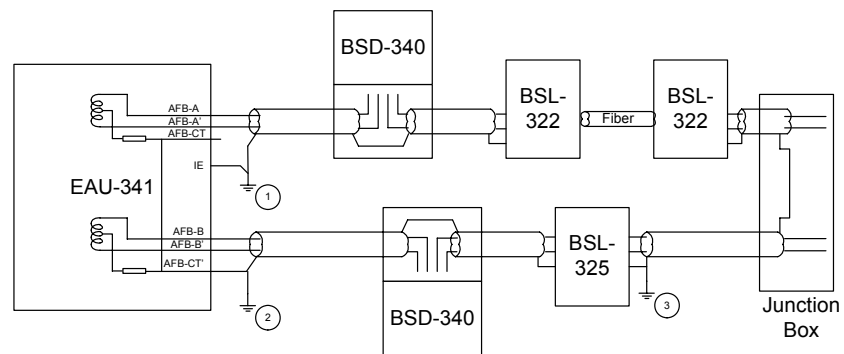

The cable shield is referenced to earth at Earthpoint 2 according to the guidelines above. Through the BSD-340 the shield is continued. There's a galvanic isolation in the Booster (BSL-325) that makes the cable (on the right side) floating. To avoid this, the Center Tap of the transformer of the AutoFieldBus (internal in the BSL-325) is terminated to the local Earth at Earthpoint 3.

An alternative is to rather bring the reference from the other side of the Booster across it, to continue the shield in that way. Note that the bus needs to be referenced by connecting the CenterTap (pin 3 or 6) to Earth. On the left side, this is ensured by the AFB-CT to Earth at the EAU-341, while the BSL-325 right side needs to be tied to Earth or to the reference of it's left side, by for instance connecting pin 3 to 6.

Further on, the BSL-322 to BSL-322 also isolates. If there had been several fiber jumps, each individual cable segment between the fiber segments would have to be earthed. In this case, the segment following passes through a BSD-340, the shield is kept continuous and it is referenced to earth at Earthpoint 1, close to the EAU-341. An alternative to this would be to terminate at the other end of this segment, at the BSL-322.

The main rule is: Ensure that all segment's shield are terminated at one end and one end only.

Dual Earth systems acts similar to the description of the PowerLoop, as long as the inner Instrumental Earth shield is kept according to the above rules, the outer protective shield may be terminated at multiple locations.

5.6.6 Earth Fault Detection AutoFieldBus

The enabling of the Earth Fault detection mechanism has been described earlier. It monitors the cable segment that is electrically connected to the EAU-341 loop driver. However, if the cable is interrupted electrically by a BSL-325 Booster or a Fibre modem, these segments may need additional Earth Fault Monitoring. This may be achieved by including a BSD-321 into this segment, and enable the Earth Fault Monitoring at this device.

Care must be taken to avoid two units monitoring the same segment, as they may interfere with each other on this feature.

6. PowerLoop Calculator Tool

6.1 Introduction

The PowerLoop Calculator Tool is an integrated part of the AutoSafe Configuration Tool. The tool allows you to define and edit a Power Loop with a number of Loop Units.

Based on the power consumption and the cable loss, the tool presents a go/no-go test to the user. The defined Power Loop can be saved for possible changes at a later stage.

The tool can be used with loose relation to the actual configuration, based on the fact that the cabling itself is analysed. The similar mechanism is used for the Loop Calculator.

The upper part (white list box) shows the calculation assuming a break after the *last* point. The lower part (white list box) shows the calculation assuming a break before the *first* point.

Each segment of the PowerLoop is described by one line in the calculation sheet. The total cable segment loss is determined as a sum of cable resistance, junction loss in terminals/connectors and the internal switches in the units. The voltage calculated at each unit is actually the internal voltage after the PowerLoop isolation switches, i.e. some internal loss adds to the external cable loss.

The loss of the first cable segment includes this internal loss of the loop driver.

The calculator iterates the loop, and verifies that the total power consumption and voltage available at each loop unit is within specifications.

6.2 Operating The PowerLoop Calculator Tool

6.2.1 Loop driver type

Select first the PowerLoopDriver type (BSD-340 or BSD-340Ex)

6.2.2 Add Button

- Enter the cable length and cable dimension (the dimension is for your information only).
- Enter the specified resistive loss of the cable to be used.
- Select the detector type X33/1, BN-342 or Junction Box.
- If BN-342/EX is selected, also enter the actual load to the external equipment/detector (supplied by BN-342/EX).

Note that if illegal float values are typed or the float value is zero, a fault warning will popup.

- Press the *Add* button and a new row will be added to the list box above.

No	Cable L. [m]	Cabletype/[mm ²]	Cable [ohm/km]	Det. Type	Ext. P. [W]	Add	Load Config
0	0		0	BN-342	0	Insert Row	
End of cable back to BSD-340						Update Row	Delete
Cable Length: <input type="text" value="0"/> [m]		Cabletype/[mm ²]: <input type="text"/>				Calculate	Advanced
Cable Res: <input type="text" value="0"/> [ohm/km]							
No	Cable L [m]	Cabletype/[mm ²]	Cable [Ohm/km]	Cable [Ohm]	Det. Type	D	

The calculation is for break after last loop unit. Each row in the table shows the cable segment and the following detector. To close the loop (last detector to loop drive), the "End of cable back to BSD-340" field is used.



The tool calculates the current flow and voltage drop per segment into the table. Regressive calculation is used to approximate a result displayed in the list box.

No	Cable L [m]	Cabletype/[mm ²]	Cable [Ohm/km]	Cable [Ohm]	Det. Type	Det. Power [w]	Ext. Power [w]	Cable Cur [A]	Det. Volt [V]	Det Cur [A]
1	1.00		1.00	0.2020	BN-342	1.9500	1.0000	0.2613	29.89	0.0652
2	1.00		1.00	0.0020	BN-342	1.9500	1.0000	0.1961	29.86	0.0653
3	1.00		1.00	0.0020	BN-342	1.9500	1.0000	0.1308	29.83	0.0654
4	1.00		1.00	0.0020	BN-342	1.9500	1.0000	0.0654	29.82	0.0654
Sum:	4.00m			1.01ohm		7.80w				

The Power In, Power Out and Cable Loss are calculated.

Power In	Voltage In	Power Dissipation	Power Out	Cable Loss
4.28 W	24 V	0.64 W	3.64 W	0.76 W

Power In: Power supplied to the BSD-340, i. e. the total power consumption.

Power Dissipation: To find out the total power/heat budget, the dissipated power from the BSD-340 inside the rack can be calculated. Simply calculate the power dissipation by Power In minus Power Out. Then add a comment in the Help about this field, to inform of the intention.

Power Out: Power delivered to the loop from the BSD-340.

Cable Loss: Power lost in the cable. It should be observed in order to ensure efficiency in the system, this is wasted power.

6.2.3 Insert Row Button

- Select a row in the list box above to insert the new row by clicking the leftmost field.
- Enter the cable length, cable resistance (in Ohm per km), plus external power for BN-342/EX unit if necessary.
- Enter a textual description of the cable type and square area (or diameter) for information in the "cable dim/type" box.
- Select the detector type, then press the *Insert Row Button*. When pressing the *Insert Row Button*, the tool automatically performs a new calculation and verification.

6.2.4 Update Row Button

- Select a row in the list box above to update a row.
- Change the cable length, cable resistance (in Ohm per km), plus external power if necessary and/or detector type.
- Press the *Update Row Button*. When pressing the *Update Row Button*, the tool automatically performs a new calculation and verification.

6.2.5 Delete Row Button

- Select a row in the list box above to delete a row, then press *Delete Row Button*.

When pressing the *Delete Row Button*, the tool automatically performs a new calculation and verification.

6.2.6 Load Config Button

The Power Loop Calculator dialogue is modeless, thus it is possible to do configuration while the dialogue is open. In this way, the loop data (detectors in sequence) which is entered in the System View can be loaded.

- To load a configured power loop into the Power Loop Calculator, select a Power Loop (BSD-340) in the Tree View (System View).
- Press the *Load Config Button* in the Power Loop Calculator.

The gas detectors added to the selected power loop will appear in the list box in the Power Loop Calculator with default cable length (10 m) and cable dimension (1 mm²). The tool automatically performs a new calculation and verification.

6.2.7 Calculate Button

To describe the end of the loop, a unit “End segment” is entered – this consists of the cable segment back to the loop driver only.

- Enter the cable length and cable resistance (in Ohm per km). If illegal float values are typed or the float value is zero, a fault warning will popup.

End of cable back to BSD-340

Cable Length: [m] Cabletype/[mm²]:

Cable Res: [ohm/km]

When pressing the *Calculate Button*, the tool automatically enters values in the list box below and performs a new calculation and verification. The calculation is for break after last loop unit.

6.2.8 Graphical Button

This view shows only the loop units and the cable segments. If a (or several) Junction Box is included, this will not be shown in the graphical view.

The cable segment will show only the closest cable information, causing this cable characteristics and resistance (to be observed in the view) not to be perfect. However the current flow and voltages at each loop unit will be calculated correct.

Note that it is assumed an internal resistance in the loop unit itself caused by connections and the internal electronic switches, so that the calculated voltage at the loop unit (internally) will be slightly different from what is observed at the actual external connection points.

- Press the *Graphical Button* to view a graphical presentation of the Power Loop. Two types of calculations are possible, “Break after last loop unit” and “Break before first loop unit”.
- To view the calculation in the first list box, in the Break Point area, select “Break after last loop unit” or “Break before first loop unit”.
- To update the calculation in the Detector area and Cable area for “Break after last loop unit”, press each button in the graphical view.
- To update the calculation in the Detector area and Cable area for “Break before first loop unit”, press each button in the graphical view.

Power Loop BSD-340

Break Point

Break after last loopunit.
 Break before first loopunit.

Detector

Detector No. (LSI):

Detector Power:

External Power:

Detector Volt:

Detector Current:

Update Close

Power Loop BSD-340

Break Point

Break after last loopunit.
 Break before first loopunit.

Detector

Detector No. (LSI):

Detector Power:

External Power:

Detector Volt:

Detector Current:

Update Close

6.2.9 Ambient Temperature

A maximum ambient temperature of the BSD-340 Loop Driver must be entered.

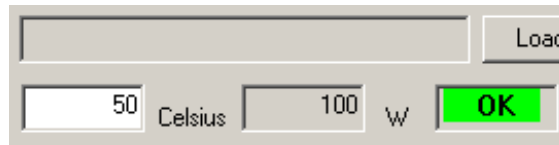

The screenshot shows a graphical user interface for entering ambient temperature. It features a large empty text box at the top right with a 'Load' button next to it. Below this, there are two smaller input fields: the first contains the number '50' followed by the text 'Celsius', and the second contains the number '100' followed by the text 'W'. To the right of these fields is a prominent green button labeled 'OK'.

The ambient temperature of the BSD-340 affects the maximum delivered power to the Power Loop.

6.2.10 Save and Load File

The data entered from the user shall be saved to a file at request of the user, and same data may be read at a later stage for editing. All data in the current sheet will be lost if a file is read (make a warning).



The screenshot shows a file management interface. It includes a text box containing the filename 'OilandGasConfig_Loop1.csv'. To the right of the text box are two buttons: 'Load File' and 'Save File'.

6.2.11 American Wire Gauge (AWG)

The conversion table puts into an exact relation the American Wire Gauge (AWG) number with the cross-section measured in mm².

The first column reports the AWG number, the second the corresponding **diameter** of the cable in mm, while the third reports the equivalent **cross-section** area in mm². The table shows some examples of cables available, and their characteristics. To ensure safe margin, specified data for the type to be used must be achieved and entered in the calculation tool.

Wire area	Wire dia	AWG	Type wire	Ω/km
1.0			Solid	17,5
1.5	1.60		Stranded	12-18
1.31	1.29	16	Stranded	13.7
1.76	1.5	16	Stranded	13-14.3
1.63	2.0	14	Solid	8.6
2.5	2.0		Stranded	7.41
3.30	2.05	12	Solid	5.4
4.0	2.26		Solid	4.35
4.0	2.55		Stranded	4.61
4.56	2.41	12	Stranded	5.4
6.0	3.15		Stranded	3.1
6.83	2.95	10	Stranded	3.22
10.0	4.05		Stranded	1.84
10.93	3.73	8	Stranded	2.20
16.0	5.15		Stranded	1.15
17.13	4.67	6	Stranded	1.54
25.0	6.4		Stranded	0.73
27.34	5.90	4	Stranded	0.82
43.12	7.41	2	Stranded	0.49

Note that this table shows one wire of the pair only. This single wire data shall be entered per cable segment in the PowerCalcTool, and the tool takes into account the loss of the pair of cables, plus the unit's internal connection loss and safety margin.

7. Operation

7.1 IFG-specific Menus

The IFG-specific menus are included in the Show Status Menu (Inhibited Points) and Service Menu (Oil and Gas Commands).

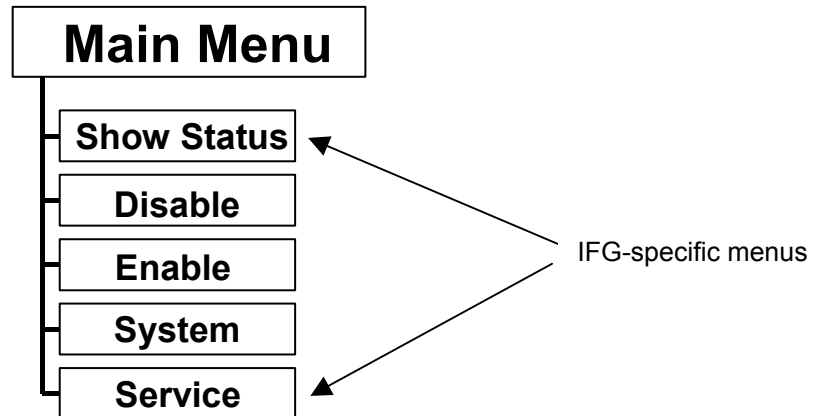

The menu structure on the following page shows the Integrated Fire and Gas Menu Structure for AutoSafe Release 3.5.0.

7.2 Menu Structure – AutoSafe 3.5.0 - IFG

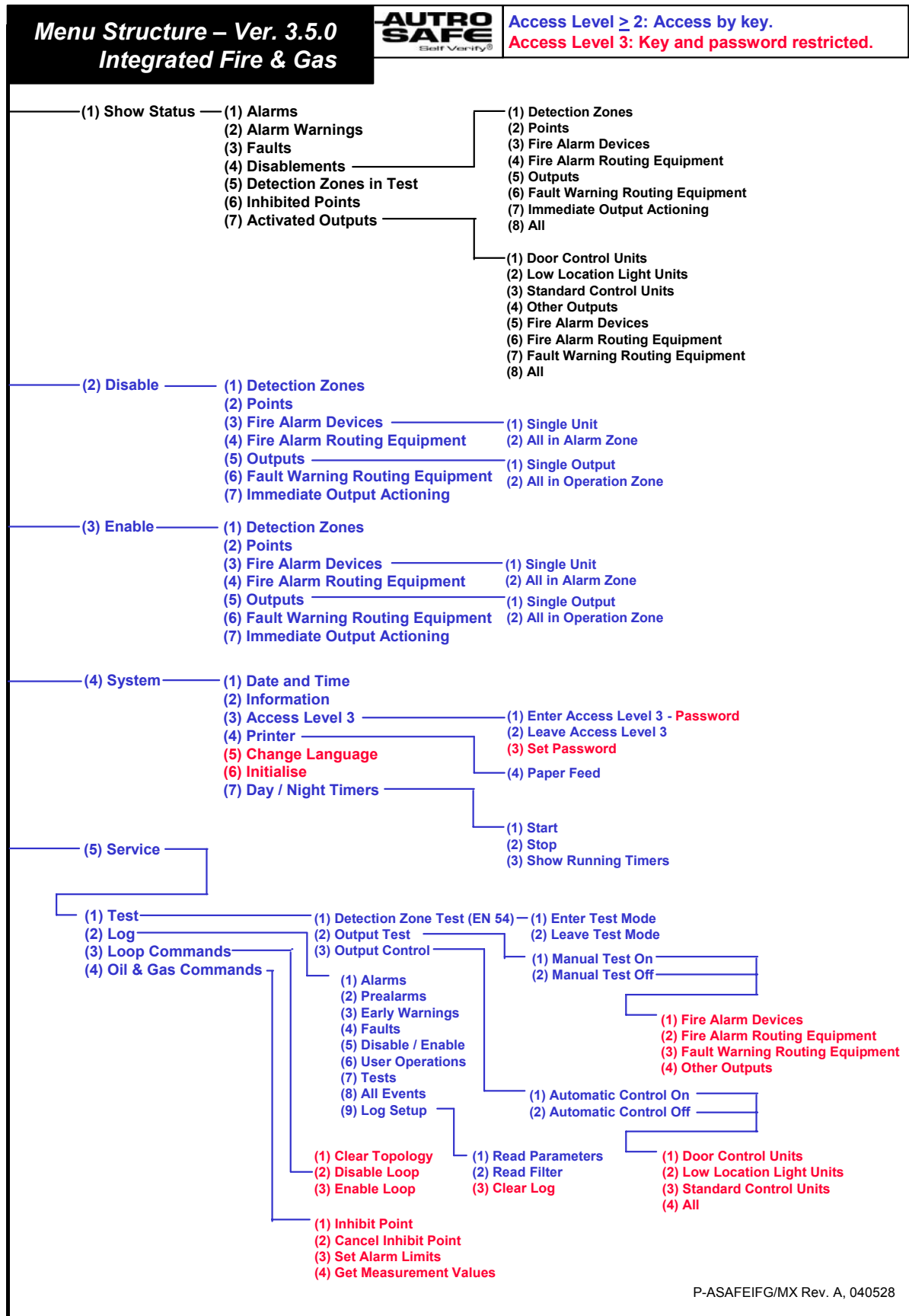

P-ASAFEIFG/MX Rev. A, 040528



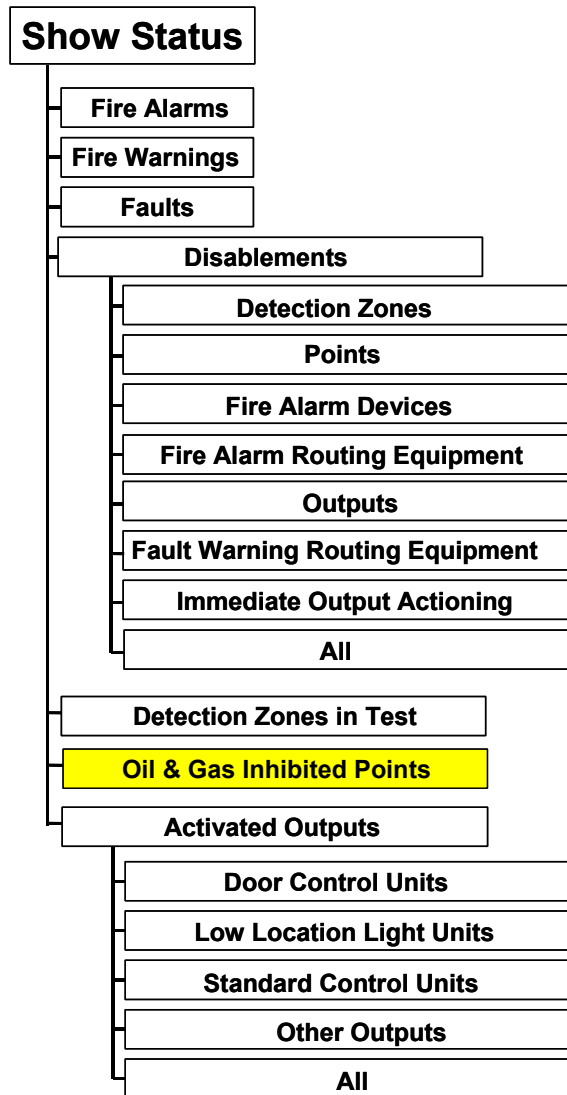

7.3 Show Status Menu / Oil&Gas Inhibited Points

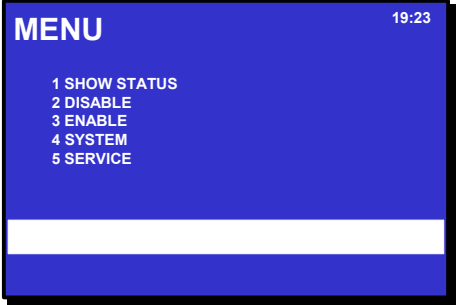
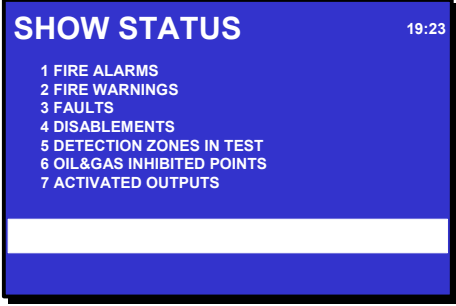

7.3.1 Show Status – Oil & Gas Inhibited Points

This menu gives detailed information on Oil & Gas Inhibited points.

The *example* below describes how to view the current status of Oil and Gas Inhibited Points.

Step	Actions to be taken	Display Indication
1	To enter the Main Menu, press 	
2	To select SHOW STATUS, press 1.	
3	To select OIL&GAS INHIBITED POINTS, press 6.	
4	To move the cursor to the desired selection, scroll with the arrow buttons  or 	
5	To view detailed zonal information for the selected detection zone, press 	
6	To view Inhibited Point(s) for the selected detection zone, press Action Digit 1 (SHOW POINTS).	
7	To return (each step backwards), press 	

7.4 Service Menu / Oil&Gas Commands

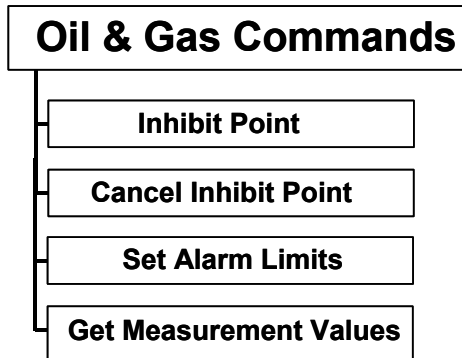







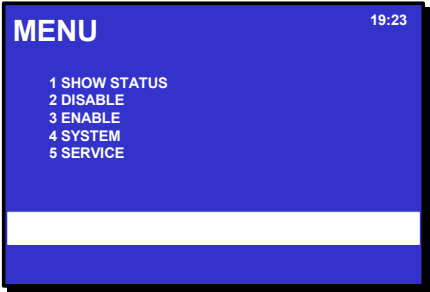
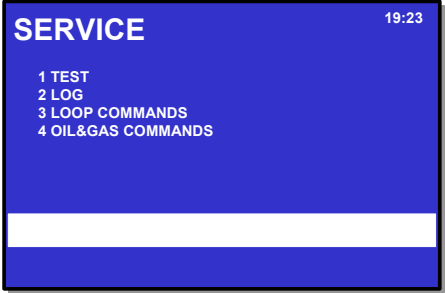

7.4.1 Inhibit Point

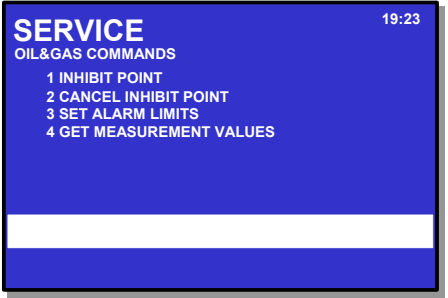
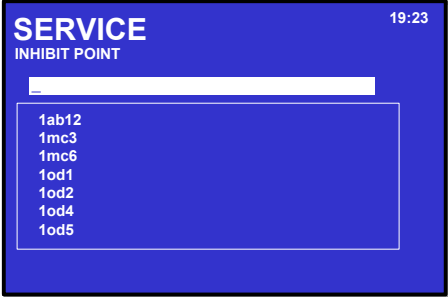
All loop input units can be inhibited. When one or several points are inhibited, the point(s) will not signal alarm to outputs. An inhibited point will however present an alarm, prealarm and early warning on all panels and AutoCom as usual. This includes panel buzzer, panel LEDs and panel LCD display.

It is only possible to inhibit a unit from the panel menu or via AutoCom. An inhibited point will be inhibited until the unit is uninhibited, either by a manual operation or by timeout.

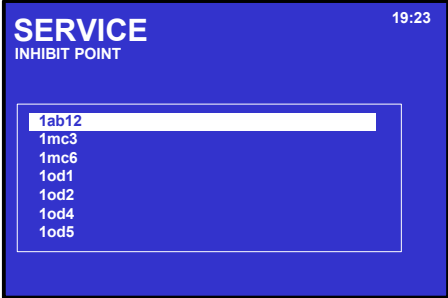
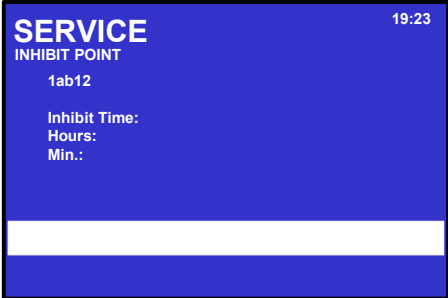
The procedure describes how to inhibit point(s).



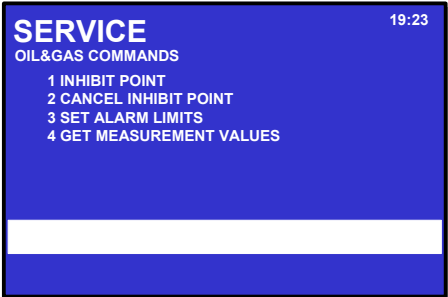

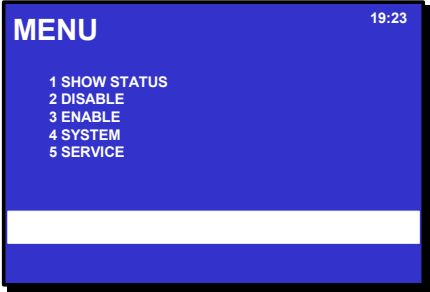
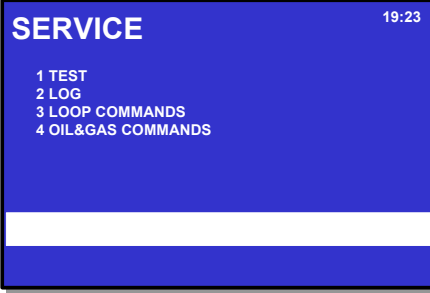
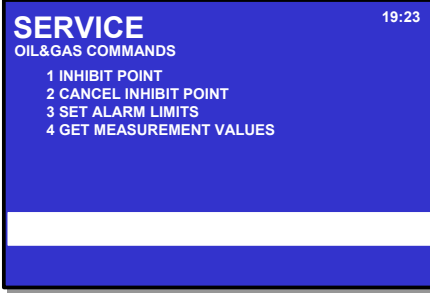
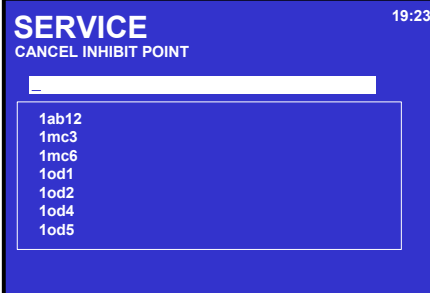

Step	Actions to be taken	Display Indication
1	To enter the Main Menu, press 	
2	To select SERVICE, press 5.	

Step	Actions to be taken	Display Indication
3	To select OIL & GAS COMMANDS, press 4.	 <p>The screenshot shows a blue screen with the title 'SERVICE' and 'OIL&GAS COMMANDS' at the top right. Below the title is a list of four options: 1 INHIBIT POINT, 2 CANCEL INHIBIT POINT, 3 SET ALARM LIMITS, and 4 GET MEASUREMENT VALUES. The time '19:23' is displayed in the top right corner.</p>
4	To select INHIBIT POINT, press 1.	 <p>The screenshot shows a blue screen with the title 'SERVICE' and 'INHIBIT POINT' at the top right. Below the title is a list of six options: 1ab12, 1mc3, 1mc6, 1od1, 1od2, 1od4, and 1od5. The time '19:23' is displayed in the top right corner.</p>
5	<p>Use the keyboard to enter text into the input box -</p> <p>OR ,- as shown in this example:</p> <p>To select a point, press</p>  <p>then scroll downwards by pressing</p>  <p>or move up again by pressing</p> 	 <p>The screenshot shows a blue screen with the title 'SERVICE' and 'INHIBIT POINT' at the top right. Below the title is a list of six options: 1ab12, 1mc3, 1mc6, 1od1, 1od2, 1od4, and 1od5. The time '19:23' is displayed in the top right corner. A white input box is visible at the top of the list, containing the text '1ab12'.</p>
6	To accept the selected point, press	 <p>The screenshot shows a blue screen with the title 'SERVICE' and 'INHIBIT POINT' at the top right. Below the title is a list of six options: 1ab12, 1mc3, 1mc6, 1od1, 1od2, 1od4, and 1od5. The time '19:23' is displayed in the top right corner. A white input box is visible at the top of the list, containing the text '1ab12'. Below the list, the text 'Inhibit Time:' is followed by 'Hours:' and 'Min.:'. A white bar is visible at the bottom of the screen.</p>
7	<p>Enter hours, then press</p>  <p>Enter minutes, then press</p>  <p>To execute the command (accept the inhibit time), press</p>  <p>once more</p>	 <p>The screenshot shows a blue screen with the title 'SERVICE' and 'OIL&GAS COMMANDS' at the top right. Below the title is a list of four options: 1 INHIBIT POINT, 2 CANCEL INHIBIT POINT, 3 SET ALARM LIMITS, and 4 GET MEASUREMENT VALUES. The time '19:23' is displayed in the top right corner. A white bar is visible at the bottom of the screen.</p>

7.4.2 Cancel Inhibit Point

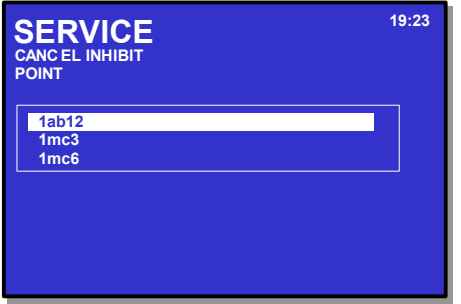
The procedure describes how to cancel the inhibition of point(s).

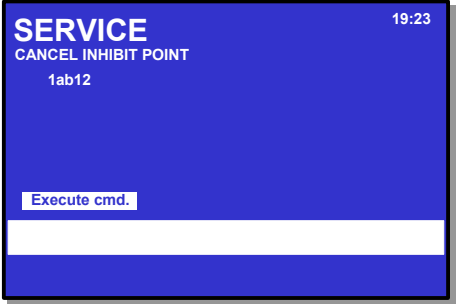

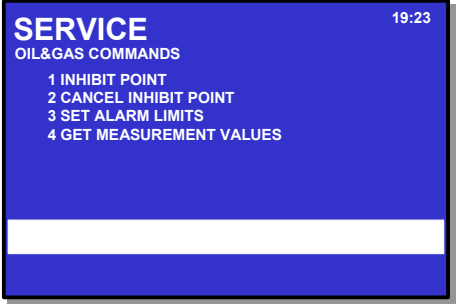





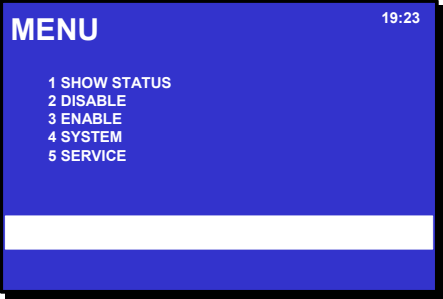
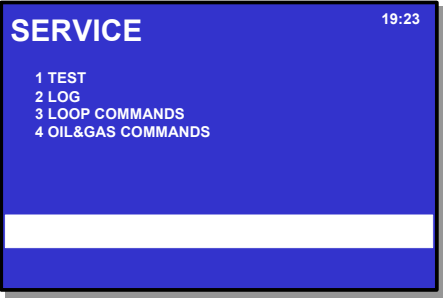
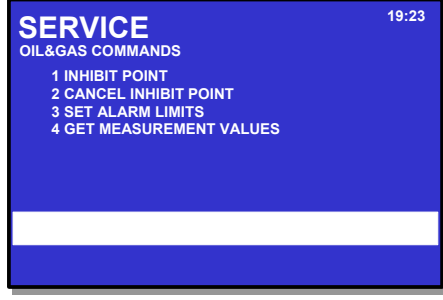
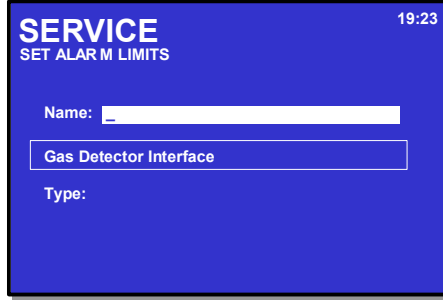

Step	Actions to be taken	Display Indication
1	To enter the Main Menu, press 	
2	To select SERVICE, press 5.	
3	To select OIL & GAS COMMANDS, press 4.	
4	To select CANCEL INHIBIT POINT, press 2.	

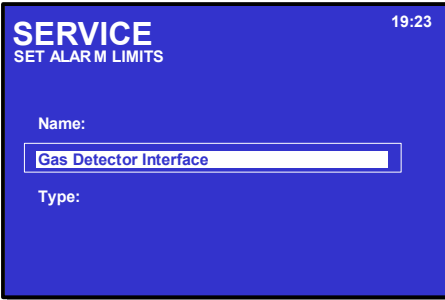
Step	Actions to be taken	Display Indication
5	<p>Use the keyboard to enter text into the input box -</p> <p>OR , - as shown in this example:</p> <p>To select a point, press</p>  <p>then scroll downwards by pressing</p>  <p>or move up again by pressing</p> 	
6	<p>To accept the selected point, press</p> 	
7	<p>To execute the command, press</p> 	

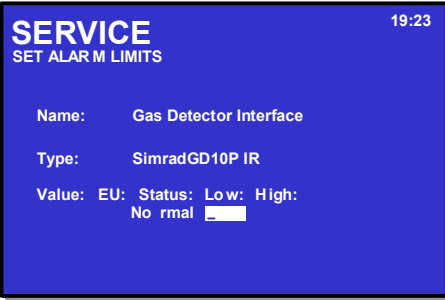
7.4.3 Set Alarm Limits

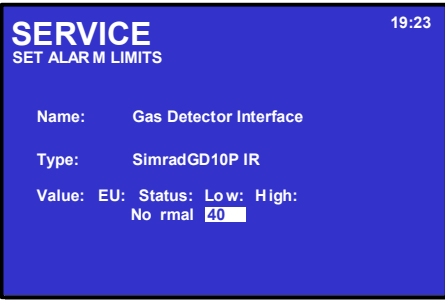

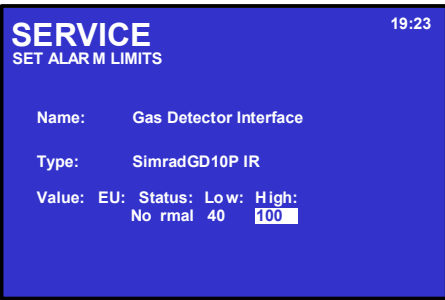

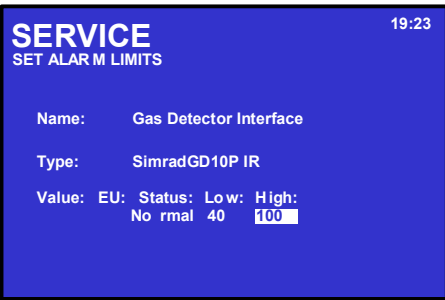

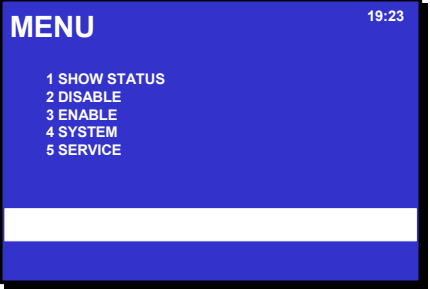
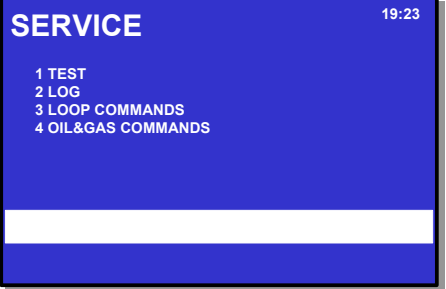
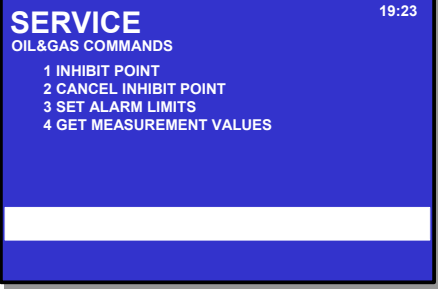
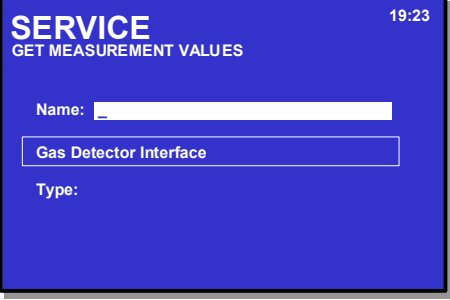

The *Set Alarm Limits* command allows you to change a gas detector's alarm limit for *Low Alarm* and *High Alarm*.

Step	Actions to be taken	Display Indication
<p>1</p>	<p>To enter the Main Menu, press </p>	
<p>2</p>	<p>To select SERVICE, press 5.</p>	
<p>3</p>	<p>To select OIL & GAS COMMANDS, press 4.</p>	
<p>4</p>	<p>To select SET ALARM LIMITS, press 3.</p>	

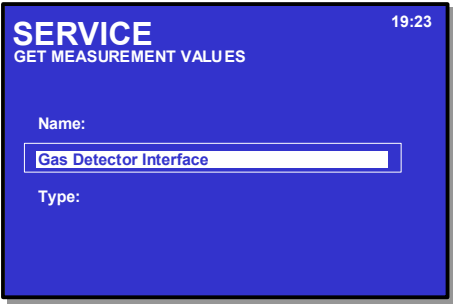
Step	Actions to be taken	Display Indication
<p>5</p>	<p>Use the keyboard to enter text into the input box -</p> <p>OR , – as shown here</p> <p>To select a point, press</p>  <p>then scroll downwards by pressing</p>  <p>or move up again by pressing</p> 	
<p>6</p>	<p>To accept the selected point press, press</p> 	
<p>7</p>	<p>Use keyboard to enter low value, press</p> 	
<p>8</p>	<p>Use keyboard to enter high value, press</p> 	
<p>9</p>	<p>To execute the command (accept the high-low values for the point), press</p> 	

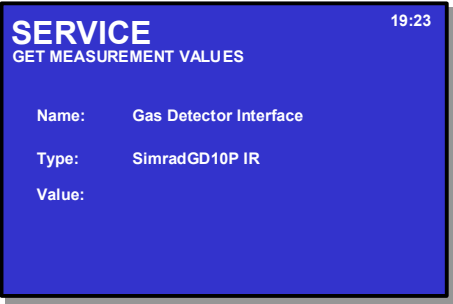
7.4.4 Get Measurement Values

Step	Actions to be taken	Display Indication
<p>1</p>	<p>To enter the Main Menu, press </p>	
<p>2</p>	<p>To select SERVICE, press 5.</p>	
<p>3</p>	<p>To select OIL & GAS COMMANDS, press 4.</p>	
<p>4</p>	<p>To select GET MEASUREMENT VALUES, press 4.</p>	

Step	Actions to be taken	Display Indication
<p>5</p>	<p>Use the keyboard to enter text into the input box -</p> <p>OR , – as shown here</p> <p>To select a point, press</p>  <p>then scroll downwards by pressing</p>  <p>or move up again by pressing</p> 	
<p>6</p>	<p>To accept the selected point press, press</p> 	
<p>7</p>	<p>Use keyboard, press</p> 	
<p>8</p>	<p>Use keyboard, press</p> 	
<p>9</p>	<p>To execute the command (accept the measurements for the point), press</p> 	

7.5 Show All Points

In systems configured for IFG-functionality, the command *Show all points* is shown in the event of an alarm (Action Digit 1). Using this command will give a list of all points in alarm for *all* Detection Zones.

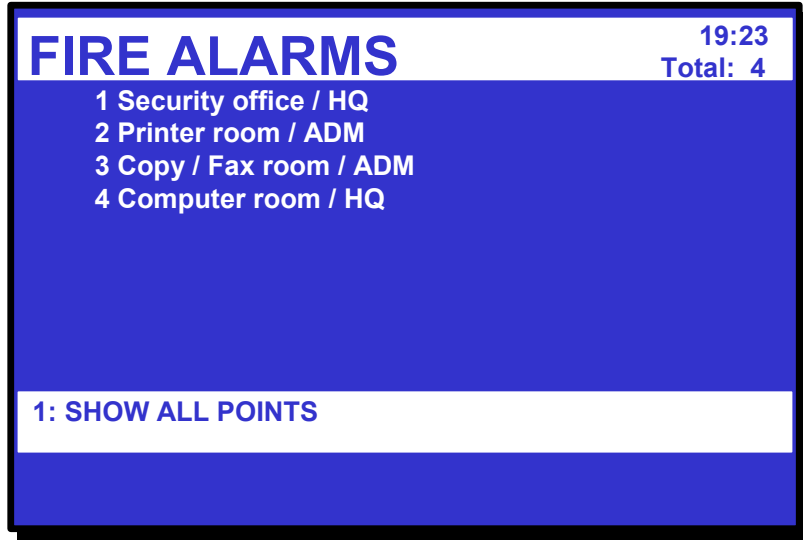

The example above shows a situation where no detection zones are selected.

8. Troubleshooting

8.1.1 BSD-321 / EAU-341

Problem / Situation / Fault message	Possible Cause	Action
Point Not responding.	<ul style="list-style-type: none"> The wrong protocol has been used for a detector. 	
The system is sensitive to external noise / interference when, for example, lights are switched on or thermostats are activated.	<ul style="list-style-type: none"> Missing reference to RS-485 Break on one of the wires The RS-485 cable is too long (exceeds the maximum length). 	
Only short messages are transmitted.	<ul style="list-style-type: none"> During initialisation a great number of messages are transmitted. Faults tend to occur more frequently. During normal operation the system will be more stable. 	
Earth fault of AFB leads to communication faults.	<ul style="list-style-type: none"> Erronous pair connection, somewhere the CT (CT=name?) and on of the pair wires have been swapped. This may work fine, but damages communication in the event of an Earth fault. 	<p>AFB earthing and shielding: In a system that includes several AFB units, there are several options to achieve proper Earthing, and also to include earth fault detection. It is important to keep in mind the various references, sense input etc. For example, a EAU-341 is defined to sense earth faults of AFB. The shield of the AFB is tied to Earth, but the Center tap (CT) is tied to the Earth fault sense input. Out somewhere at the AFB loop a BSD-321 has tied the CT to Shield, which together make an earth fault. Isolated, per product, this is allowed as a proper installation, but not at a system view. See "System Shielding and Earthing" chapter 5.6, for further directions.</p>

8.1.2 Examples of Fault Messages:

AutroFieldBus faults:

Unit removed from AutroFieldBus:

Two or more fault messages

Fault message 1:

```
-----
----
Cabel problem detected on loop
between points
  <Tag name Loopdiver, one side of the missing unit> (LSI)
  <Tag name Loopdiver, other side of the missing unit> (LSI)
Loop and panel
  <EAU-341 Tag> (A)
  <Panel Tag> (Panel switch
setting)
Status
  Not accepted <F>/<L>
-----
----
<A>: Internal data (Loop local ID)
<F>: Internal data
<L>: Internal data
```

Fault message 2:

```
-----
----
FAULT:
  <EAU-341 tag name>
Status
  Not accepted
Type:
  AutroFieldBus -
  Loop unit missing on loop
Data
  <A>, <B>, <C>
Reported by
  <F>, <L>, <M>
-----
----
where:
  <A>: Internal data
  <B>: Internal data (Loop local ID)
  <C>: Missing Loop driver address
  <F>: Internal data
  <L>: Internal data
  <M>: Internal data
```

Additional faults (Point not responding) for points connected to the missing loop driver

To resolve fault:

- 1 -
 - 1.1 - Reconnect missing unit
 - OR
 - 1.2 - Replace unit if broken
- 2 - Reset AutroSafe

Broken loop (open circuit) or Loop short circuit:

Fault message:

```
-----
----
Cabel problem detected on loop
between points:
  <Tag name Loopdiver, one side of the problem> (LSI)
  <Tag name Loopdiver, other side of the problem> (LSI)
Loop and panel
  <Loop driver Tag> (Loop driver
address)
  <Panel Tag> (Panel switch
setting)
-----
----
```

To resolve fault:

- 1 - Fix broken wire
- 2 - Reset AutroSafe

AutroFieldBus ground fault:

Fault message:

```
-----
----
FAULT:
  <Loop driver Tag>
Status
  Not accepted
Type:
  AutoFieldBus -
  Ground Fault detected

Reported by
  <F>,<L>,<M>
-----
```

```
where:
  <F>:   Internal data
  <L>:   Internal data
  <M>:   Internal data
```

To resolve fault:

- 1 - Remove ground fault
- 2 - Reset AutoSafe if fault is still present on panel

```
-----
-----
-----
```

PowerLoop faults:

Unit removed from PowerLoop bus:

Two fault messages
 Fault message 1:

```
-----
----
Loop is open
between points
  <Tag name point, one side of the break> (LSI)
  <Tag name point, other side of the break> (LSI)
Loop and panel
  <Loop driver Tag> (Loop driver
address)
  <Panel Tag> (Panel switch
setting)
-----
----
```

Fault message 2:

```
-----
----
FAULT:
  <Point Tag>
Status
  Not accepted
Type:
  Point -
  Point not responding
Data
  <A>,<B>,<C>,<D>
Reported by
  <F>,<L>,<M>
-----
```

```
where:
  <A>:   Loop driver address
  <B>:   Point C-address
  <C>:   Internal data
  <D>:   Internal data
  <F>:   Internal data
  <L>:   Internal data
  <M>:   Internal data
```

To resolve fault:

- 1 - Disable relevant loop
- 2 -
 - 2.1 - Reconnect missing unit
 - OR
 - 2.2 - Replace unit if broken
- 3 - Enable relevant loop

Broken loop (open circuit):

Fault message:

```
-----  
----  
Loop is open  
between points:  
  <Tag name point, one side of the break> (LSI)  
  <Tag name point, other side of the break> (LSI)  
Loop and panel  
  <Loop driver Tag> (Loop driver  
address)  
  <Panel Tag> (Panel switch  
setting)  
-----  
----
```

To resolve fault:

- 1 - Disable relevant loop
- 2 - Fix broken wire
- 3 - Enable relevant loop

Loop short circuit:

Fault message:

```
-----  
----  
Loop short circuit  
between points:  
  <Tag name point, one side of the break> (LSI)  
  <Tag name point, other side of the break> (LSI)  
Loop and panel  
  <Loop driver Tag> (Loop driver  
address)  
  <Panel Tag> (Panel switch  
setting)  
-----  
----
```

To resolve fault:

- 1 - Disable relevant loop
- 2 - Remove short circuit
- 3 - Enable relevant loop

Loop ground fault:

Fault message:

```
-----  
----  
FAULT:  
  <Loop driver Tag>  
Status  
  Not accepted  
Type:  
  PowerLoop -  
  Ground Fault detected  
Data  
  <A>, <B>, <C>, <D>, <E>  
Reported by  
  <F>, <L>, <M>  
-----  
----
```

where:

```
<A>: Internal data  
<B>: Loop driver address  
<C>: Internal data  
<D>: Internal data  
<E>: 1=Plus wire is grounded  
      2=Minus wire is grounded  
<F>: Internal data  
<L>: Internal data  
<M>: Internal data
```

To resolve fault:

- 1 - Remove ground fault
- 2 - Reset AutoSafe if fault is still present on panel

```
-----  
-----  
-----
```

BN-342 faults:

Simrad GD10 configuration:

**Faulty power wiring or
Detector without power or
4-20mA open circuit or
faulty GD10 detector:**

NB: The GD10 will give 0mA for a 60 second period after powerup

Fault message:

FAULT:
 <Point Tag>
Status
 Not accepted
Type:
 Point -
 Sensor: Failure

Reported by
 <F>, <L>, <M>

where:
 <F>: Internal data
 <L>: Internal data
 <M>: Internal data

To resolve fault:

- 1.1 - Replace faulty detector
 OR
- 1.2 - Repair faulty wiring.
- 2 - Reset AutoSafe if fault is still present on panel

Simrad GD10 early clean optics:

Fault message:

FAULT:
 <Point Tag>
Status
 Not accepted
Type:
 Point -
 Sensor: Early clean optics

Reported by
 <F>, <L>, <M>

where:
 <F>: Internal data
 <L>: Internal data
 <M>: Internal data

To resolve fault:

- 1.1 - Replace detector
 OR
- 1.2 - Clean the detector optical parts according to SimradGD10 manual.
- 2 - Reset AutoSafe if fault is still present on panel

Simrad GD10 dirty optics:

Fault message:

FAULT:
 <Point Tag>
Status
 Not accepted
Type:
 Point -
 Sensor: Dirty optics

Reported by
 <F>, <L>, <M>

where:
 <F>: Internal data
 <L>: Internal data
 <M>: Internal data

To resolve fault:
 1.1 - Replace detector
 OR
 1.2 - Clean the detector optical parts according to SimradGD10
manual.
 2 - Reset AutroSafe if fault is still present on panel

**Sieger Excel OPGD or Sieger Excel OPGD duct
configuration:**

**Faulty power wiring or
4-20mA open circuit or
faulty Sieger Excel OPGD detector:**

Fault message:

FAULT:
 <Point Tag>
Status
 Not accepted
Type:
 Point -
 Sensor: General fault

Reported by
 <F>,<L>,<M>

where:
 <F>: Internal data
 <L>: Internal data
 <M>: Internal data

To resolve fault:
 1.1 - Replace faulty detector
 OR
 1.2 - Repair faulty wiring.
 2 - Reset AutroSafe if fault is still present on panel

Sieger Excel OPGD (duct) dirty optics:

Fault message:

FAULT:
 <Point Tag>
Status
 Not accepted
Type:
 Point -
 Sensor: Dirty optics

Reported by
 <F>,<L>,<M>

where:
 <F>: Internal data
 <L>: Internal data
 <M>: Internal data

To resolve fault:
 1.1 - Replace detector
 OR
 1.2 - Clean the detector optical parts according to Sieger
excel OPGD manual.
 2 - Reset AutroSafe if fault is still present on panel

Sieger Excel OPGD (duct) beam blocked:

Fault message:

```

-----
----
FAULT:
  <Point Tag>
Status
  Not accepted
Type:
  Point -
  Sensor: Beam blocked

Reported by
  <F>, <L>, <M>
-----

```

```

----
where:
  <F>: Internal data
  <L>: Internal data
  <M>: Internal data

To resolve fault:
  1 - Remove items blocking the beam between transmitter and
  receiver
  2 - Reset AutroSafe if fault is still present on panel
-----

```

**Dräger XPTox configuration:
 Faulty power wiring or
 4-20mA open circuit or
 faulty Dräger detector:**

```

Fault message:
-----
----
FAULT:
  <Point Tag>
Status
  Not accepted
Type:
  Point -
  Sensor: General fault

Reported by
  <F>, <L>, <M>
-----

```

```

----
where:
  <F>: Internal data
  <L>: Internal data
  <M>: Internal data

To resolve fault:
  1.1 - Replace faulty detector
  OR
  1.2 - Repair faulty wiring.
  2 - Reset AutroSafe if fault is still present on panel

```

Dräger XPTox maintenance:
 Fault message:

```

-----
----
FAULT:
  <Point Tag>
Status
  Not accepted
Type:
  Point -
  Sensor: Maintenance

Reported by
  <F>, <L>, <M>
-----

```

```

----
where:
  <F>: Internal data
  <L>: Internal data
  <M>: Internal data

```

To resolve fault:

- 1.1 - Replace faulty detector
- OR
- 1.2 - Repair detector according to Dräger XpTox manual.
- 2 - Reset AutroSafe if fault is still present on panel

Dräger XPTox warning:

Fault message:

```
-----  
-----  
FAULT:  
  <Point Tag>  
Status  
  Not accepted  
Type:  
  Point -  
  Sensor: General warning  
  
Reported by  
  <F>, <L>, <M>  
-----  
-----
```

where:
<F>: Internal data
<L>: Internal data
<M>: Internal data

To resolve fault:

- 1.1 - Replace faulty detector
- OR
- 1.2 - Repair detector according to Dräger XpTox manual.
- 2 - Reset AutroSafe if fault is still present on panel

```
-----  
-----  
-----
```

BSD-321 faults:

Any configuration:

Loopback fault:

Fault message:

```
-----  
-----  
FAULT:  
  <Loop driver tag name>  
Status  
  Not accepted  
Type:  
  General protocol converter -  
  Loopback fault detected  
Data  
  <A>, <B>  
Reported by  
  <F>, <L>, <M>  
-----  
-----
```

where:
<A>: Internal data
: Internal data
<F>: Internal data
<L>: Internal data
<M>: Internal data

To resolve fault:

- 1.1 - Repair cable between channel 0 and channel 1 (ref datasheet)
- OR
- 1.2 - Replace broken BSD-321 unit.
- 2 - Reset AutroSafe if fault is still present on panel

Any configuration:

RS-485 ground fault:

Fault message:

```
-----  
-----  
FAULT:
```



```

    <Loop driver tag name>
    Status
    Not accepted
    Type:
    General protocol converter -
    Ground fault detected
    Data
    <A>
    Reported by
    <F>, <L>, <M>
    -----
  
```

 where:

```

    <A>: Internal data
    <F>: Internal data
    <L>: Internal data
    <M>: Internal data
  
```

To resolve fault:

- 1 - Remove RS-485 ground fault.
- 2 - Reset AutoSafe if fault is still present on panel

9. Reader's Comments

Please help us to improve the quality of our documentation by returning your comments on this manual:

Title: *System Description,
AutoSafe Integrated Fire & Gas Detection System,*
Ref. No.: *116-P-ASAFE-IFG/XE Rev. B, 2005-10-27*

Your information on any inaccuracies or omissions (with page reference):

Please turn the page

Suggestions for improvements

Thank you! We will investigate your comments promptly.

Would you like a written reply? Yes No

Name: -----

Title: -----

Company: -----

Address: -----

Telephone: -----

Fax: -----

Date: -----

Please send this form to: Autronica Fire and Security AS
 N-7483 Trondheim
 Norway

Tel: + 47 73 58 25 00

Fax: + 47 73 58 25 01

www.autronicafire.com/

Autronica Fire and Security AS is an international company, based in Trondheim, Norway and has a world-wide sales and service network. For more than 40 years Autronica's monitoring systems have been saving lives and preventing catastrophes on land and at sea. Autronica Fire and Security's most important business area is fire detection & security. Autronica Fire and Security stands for preservation of environment, life and property.

Quality Assurance

Stringent control throughout Autronica Fire and Security assures the excellence of our products and services. Our quality system conforms to the Quality System Standard NS-EN ISO 9001, and is valid for the following product and service ranges: marketing, sales, design, development, manufacturing, installation and servicing of:

- fire alarm and security systems
- petrochemical, oil and gas instrumentation systems for monitoring and control

In the interest of product improvement, Autronica Fire and Security reserves the right to alter specifications according to current rules and regulations.

Autronica Fire and Security AS

Fire and Security, Trondheim, Norway. Phone: + 47 73 58 25 00, fax: + 47 73 58 25 01.

Oil & Gas, Stavanger, Norway. Phone: + 47 51 84 09 00, fax: + 47 51 84 09 99.

Autronica Industrial Ltd., Watford, United Kingdom. Phone: 1923 23 37 68, fax: 1923 22 55 77.

Visit Autronica Fire and Security's Web site: <http://www.autronicafire.com/>