

Features

- Interfaces various types of flame and gas detectors with the AutoSafe Integrated Fire and Gas Detection System
- The AUTROFIELDBUS address and protocol type are easily defined by means of switches
- RS-485 connection to detectors
- Built-in protocol converters
- Trending and maintenance facilities
- Rail mounted
- Approved by FM
- EX version available



Application / Description

The BSD-321 can be configured to interface various types of detectors into the AutoSafe Integrated Fire and Gas Detection System.

BSD-321 contains a protocol converter for the specific type of detector to be interfaced. All events such as alarms, prealarms and fault warnings are transmitted to the AutoSafe Integrated Fire and Gas Detection System.

Depending on the specific detector, analogue readings of gas concentration, for example, are also transmitted for trending and maintenance purposes.

The built-in short-circuit isolator of AUTROFIELDBUS will, together with the ring topology, ensure that neither a single short-circuit nor a wire break will cause loss of functionality.

Furthermore, the BSD-321 provides optional AUTROFIELDBUS earth fault detection.

The BSD-321 basic model has RS485 communication ports for interfacing field equipment.

There can be a maximum of 31 BSD-321 units on each AUTROFIELDBUS ring.

Overview Protocol Type and Interface Switches Settings

The AUTROFIELDBUS address and type of protocol/detector are defined by on-board rotary switches.

Type of interface	Switch setting 1)	Max no of units/ BSD-321
AutoPath Pulsar, Open Path Gas Detector	70	16
SafeEye series 200/300, Open Path Gas Detector	71	16
AutoFlame CCTV Flame Detector and Video Switches	72	27 camera 2 video switches
Kidde Fenwal AnaLaser II HSSD	73	16

- 1) To select protocol type: Set address switches according to table, then press reset button. After choosing protocol set the address switches to the actual address in the range of 1-31.

Technical Specifications

Dimensions (mm)	114,5 x 120 x 45
Weight (g)	250 g
Housing material	Polyamide 6.6.
Mounting	DIN TS-35 rail
Power supply	18-32VDC
Current consumption	Typically 150-200 mA at 24VDC
Temperature range	-10 to +60 °C
Humidity	10% - 95% RH (non-condensing)
Degree of protection	IP 20
Approvals	FM Approval
Interface to detectors	Two-wire multidrop RS485
Communication loop	AUTROFIELDBUS
Cable terminals	Phoenix Combicon style Maximum 2.5 mm ² wires
Cable AUTROFIELDBUS	Refer to specification for AutoSafe
Cable RS485	Twisted pair, shielded cable Maximum 100Ω resistive loss Maximum total length 1200m Maximum cable capacitance 150 nF
Debug and download connector	MTA-style, cable XJA-029

Overview – Typical Installation

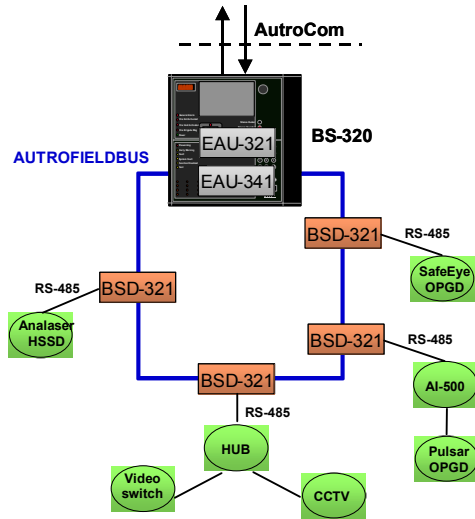

Layout / Dimensions

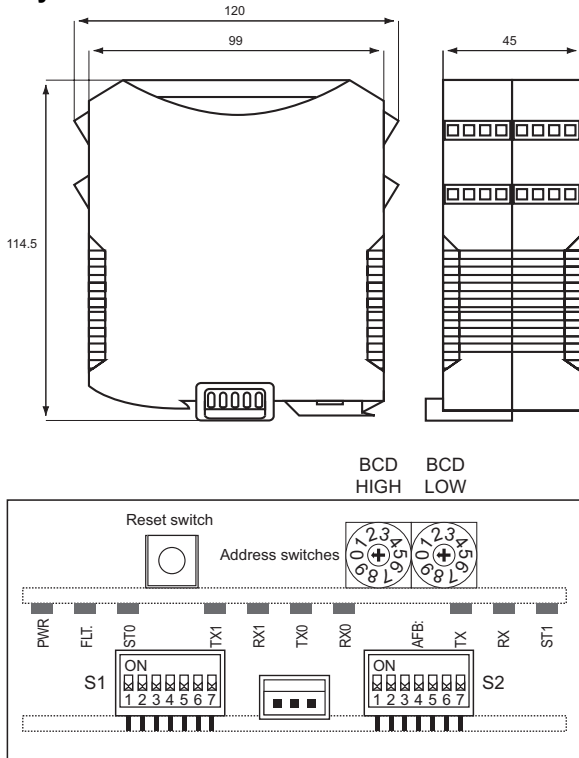

Connectors

All connections are made to plug-in screw terminals numbered 1-32.

Terminal	Function
1	AutroFieldBus A
2	AutroFieldBus A'
3	AutroFieldBus CT A
4	AutroFieldBus Earth Fault Sense
5	RX RS422_A+ Port 1
6	RX RS422_B- Port 1
7	TX RS422_X+ Port 1
8	TX RS422_Z- Port 1
9	AutroFieldBus B
10	AutroFieldBus B'
11	AutroFieldBus CT B
12	AutroFieldBus Earth Fault Sense
13	TX RS232 Port 1
14	RX RS232 Port 1
15	Signal Reference Port 1
16	Instrument Earth Port 1
17	RX RS422_A+ Port 0
18	RX RS422_B- Port 0
19	TX RS422_X+ Port 0
20	TX RS422_Z- Port 0
21	TX RS232 Service port
22	RX RS232 Service port
23	RS232 Service port Signal Reference
24	No connection
25	TX RS232 Port 0
26	RX RS232 Port 0
27	Signal Reference Port 0
28	Instrument Earth Port 0
29	+24V Input
30	0V Input
31	Instrument Earth Common
32	Protective Earth Common

Order Numbers

Order number	Description
116-BSD-321	AUTROFIELDBUS Protocol Converter

Autronica Fire and Security AS

Fire and Security, Trondheim, Norway. Phone: + 47 73 58 25 00, fax: + 47 73 58 25 01

Oil & Gas, Stavanger, Norway. Phone: + 47 51 84 09 00, fax: + 47 51 84 09 99

Maritime Sales, Spikkestad, Norway. Phone: + 47 31 29 55 00, fax: + 47 31 29 55 01

Visit Autronica Fire and Security's website: www.autronicafire.com

Obtaining RS-485 using the BSD-321 RS-422 connections

RS-485 is obtained by connecting the BSD-321 RS-422 ports in RS-485 mode. This is done by connecting the A+ and the X+ signal together, and the B- and the Y- signal. The resulting RS-485 signal names will be A+ and B-.

LED Indicators

PWR	green	Power & Heartbeat
FLT	red	BSD-321 Fault
ST0	yellow	AFB Message processed
TX1	green	Port 1 Transmits
RX1	red	Port 1 Receives
TX0	green	Port 0 Transmits
RX0	red	Port 0 Receives
TX	green	AFB Transmits
RX	red	AFB bus traffic
ST1	yellow	AFB Message received

General DIPswitch settings for all applications:

S1:

- 1 ON DC bias of RS422 RX Port 0
- 2 (*) Enable RS422 RX Earth Fault sensor Port 0
- 3 ON Enable RS-422 RX Port 0
- 4 OFF Enable RS-232 RX Port 0
- 5 ON Enable RS-485 Port 0
- 6 ON 120Ω EOL resistor of RS-422 RX Port 0
- 7 OFF 120Ω EOL resistor of RS-422 TX Port 0

S2:

- 1 OFF DC bias of RS422 TX Port 0
- 2 (*) Enable RS422 TX Earth Fault sensor Port 0
- 3 ON Enable RS-422 RX Port 1
- 4 OFF Enable RS-232 RX Port 1
- 5 ON Enable RS-485 Port 1
- 6 (*) 120Ω EOL resistor of RS-422 RX Port 1
- 7 OFF 120Ω EOL resistor of RS-422 TX Port 1

(*): Refer to text for switch position

The BSD-321 is intended for use with 24VDC power supplies. It may be used in single or dual earth systems.

BSD-321 power,
Single earth system

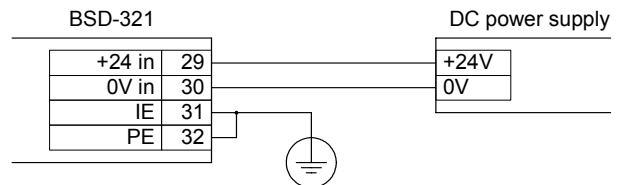

BSD-321 power,
Dual earth system

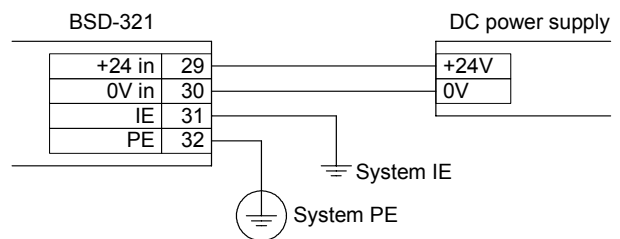

For further earth & shielding information reference to the System Description AutoSafe IFG.
Order number: 116-P-ASAFE-IFG/XE.

Autronica Fire and Security AS

Fire and Security, Trondheim, Norway. Phone: + 47 73 58 25 00, fax: + 47 73 58 25 01

Oil & Gas, Stavanger, Norway. Phone: + 47 51 84 09 00, fax: + 47 51 84 09 99

Maritime Sales, Spikkestad, Norway. Phone: + 47 31 29 55 00, fax: + 47 31 29 55 01

Visit Autronica Fire and Security's website: www.autronicafire.com

RS-485 Detector interface with loop-back

RS-485 branch connection (local loop-back):

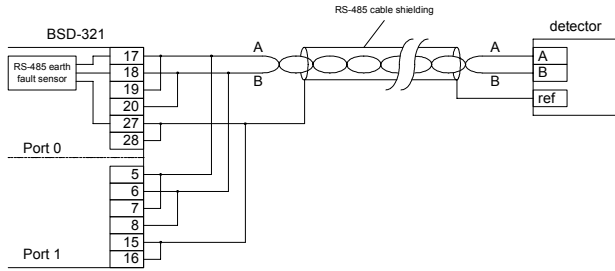

RS-485 loop connection (remote loop-back):

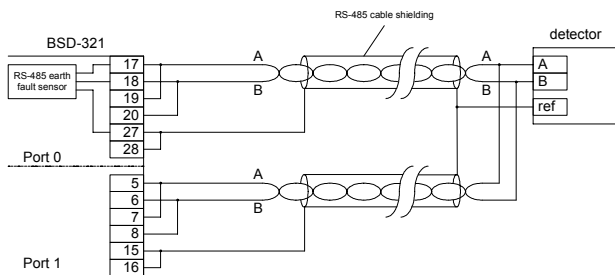

Loop-back of RS-485 can be done either locally on BSD-321 or remotely with loop to/from detector.

The BSD-321 requires a RS-485 loop-back connection. Loop-back is used to give increased system safety. The extra port verifies the communication path. This also opens the option to using RS-485 loop connection for dual communication paths to the detectors.

Loop-back for optimum safety is required for SIL2 applications (To be approved).

Switches S1 and S2 must be set accordingly for correct termination.

Local loop-back:

- Set S2-6 OFF (Disable EOL resistor for port 1)
- The detector at the other end of the RS-485 bus must enable its EOL resistor
- Remote loop-back:
- Set S2-6 ON (Enable EOL resistor for port 1)
- None of the detectors must have EOL resistors

Earth fault detection on the RS-485 bus

Earth fault detection is enabled on the RS-485 link by when S2-2 is ON. The monitoring circuit monitors unintended connection between the A+ wire (connector 17) and the port 0 ref wire (connector 28), or between the B- wire (connector 18) and the port 0 ref wire (connector 28).

The "ref" signal on the detector

The ref signal on the detector is the detectors "common" signal for the RS-485. This signal may be connected to IE (or earth in single earth systems), to the detectors power supply 0V or it may be isolated (floating).

All detectors on the same RS-485 bus must have the same reference, and this reference shall be the connections to BSD-321's reference. Both RS-485 ports are isolated to allow a floating reference.

It is essential that the connection to the RS-485 shield be done only in one point in the system if the detectors are not 100% isolated from each other (individual isolated detector power supplies and no earth reference).

Schematic of port equivalent:

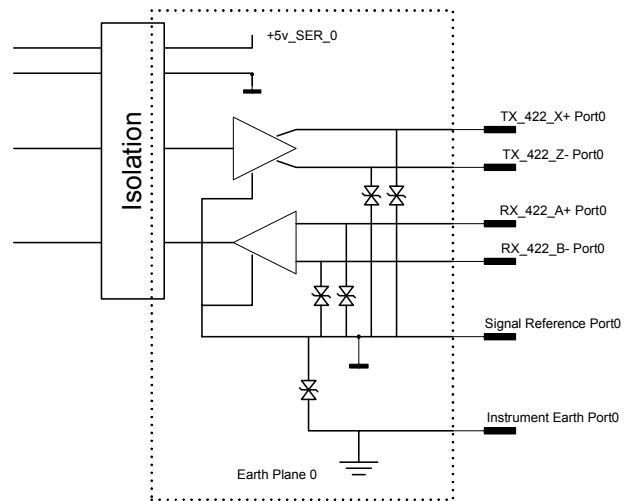

Autronica Fire and Security AS

Fire and Security, Trondheim, Norway. Phone: + 47 73 58 25 00, fax: + 47 73 58 25 01
 Oil & Gas, Stavanger, Norway. Phone: + 47 51 84 09 00, fax: + 47 51 84 09 99
 Maritime Sales, Spikkestad, Norway. Phone: + 47 31 29 55 00, fax: + 47 31 29 55 01

Earth fault detection on AUTROFIELDBUS

Earth fault detection is enabled on the AUTROFIELDBUS (AFB) interface. Note that Earth fault detection can only be enabled on one unit on each cable segment on AFB. Cable segments are isolated by using fibre modems (BSL-321/322) or boosters (BSL-325).

In systems with only one cable segment the AFB earth fault detection shall be done by the EAU-341 unit. Earth fault detection requires a connection between connector 11 and 12, and at the same time the IE connector is connected to the same earth system that an optional cable shielding is connected to.

AFB cable with continuous shield

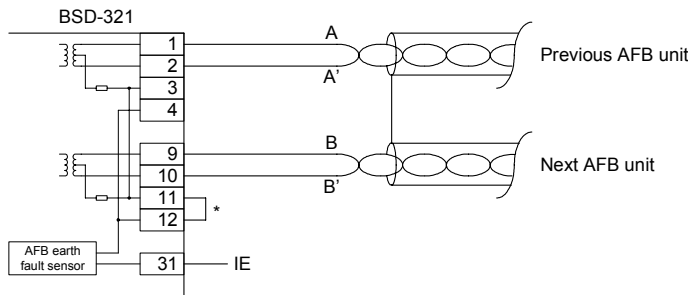

AFB cable with discontinuous shield

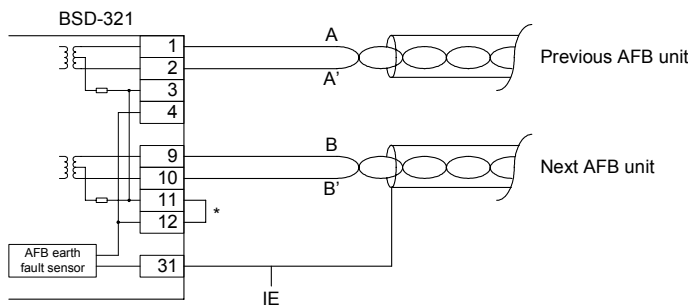

AFB cable without shield

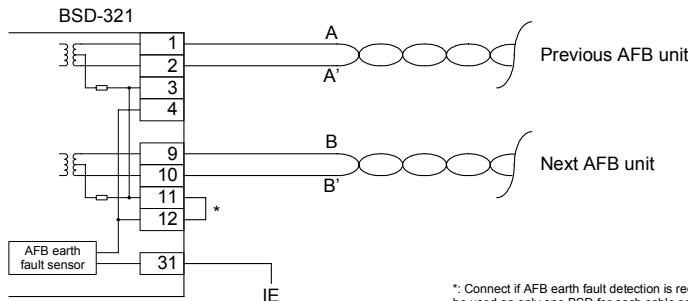

*: Connect if AFB earth fault detection is required. This feature should be used on only one BSD for each cable segment. Detection will be done towards the IE terminal (31)

Autronica Fire and Security AS

Fire and Security, Trondheim, Norway. Phone: + 47 73 58 25 00, fax: + 47 73 58 25 01

Oil & Gas, Stavanger, Norway. Phone: + 47 51 84 09 00, fax: + 47 51 84 09 99

Maritime Sales, Spikkestad, Norway. Phone: + 47 31 29 55 00, fax: + 47 31 29 55 01