



# Instructions

## Infrared Hydrocarbon Gas Detector AutroPath HC600



COPYRIGHT ©

This publication, or parts thereof, may not be reproduced in any form, by any method, for any purpose.

Autronica Fire and Security AS and its subsidiaries assume no responsibility for any errors that may appear in the publication, or for damages arising from the information in it. No information in this publication should be regarded as a warranty made by Autronica Fire and Security. The information in this publication may be updated without notice.

Product names mentioned in this publication may be trademarks. They are used only for identification.



APPLICATION .....	1	CALIBRATION .....	23
OPERATION OVERVIEW .....	2	Calibration Overview .....	23
Theory of Operation .....	2	Important Calibration Notes .....	23
Detectable Gases .....	2	Calibration Initiation .....	23
Standard Output .....	2	Detailed Calibration Procedure using	
Optional Relays .....	2	Magnetic Switch .....	23
Communication .....	3	MAINTENANCE .....	23
Recording Capability .....	3	Routine Inspection .....	23
Detection Range .....	3	Optics Cleaning .....	24
OPERATION .....	3	Protective Caps and Covers .....	24
Module Identification .....	3	TROUBLESHOOTING .....	24
Operating Modes .....	4	REPLACING HC600 TRANSMITTER/ RECEIVER ELECTRONICS MODULE .....	25
4-20 mA Current Loop Output .....	4	Module Replacement Procedure .....	25
Fault Indication .....	5	DEVICE REPAIR AND RETURN .....	26
Transmitter Lamp Operation .....	5	ORDERING INFORMATION .....	27
SPECIFICATIONS .....	6	Alignment Equipment .....	27
IMPORTANT SAFETY NOTES .....	9	Accessories .....	27
INSTALLATION .....	9	Spare Parts .....	27
Identification of Vapor(s) to be Detected .....	9	Assistance .....	27
System Location Considerations .....	9	APPENDIX A - ATEX APPROVAL DESCRIPTION .....	A-1
Module Mounting Recommendations .....	11	APPENDIX B - IECEx APPROVAL DESCRIPTION .....	B-1
24 VDC Power Supply Requirements .....	12	APPENDIX C - OTHER APPROVALS .....	C-1
Wiring Cable Requirements .....	12	APPENDIX D - HART COMMUNICATION .....	D-1
Power Wiring Size and Maximum Length .....	13		
Optional Relays .....	13		
Wiring Procedure .....	14		
STARTUP .....	17		
ALIGNMENT .....	17		
Overview .....	17		
Basic Alignment Procedure .....	17		
Aperture Kit for Short Range Applications .....	20		
Recommendations for using the HART Field Communicator .....	20		
Fine Alignment Adjustment using Partial Beam Block Tool .....	20		
Gain Level Check .....	22		





## INSTRUCTIONS

### Infrared Hydrocarbon Gas Detector AutroPath HC600

#### **IMPORTANT**

*Be sure to read and understand the entire instruction manual before installing or operating the gas detection system. This product is intended to provide early warning of the presence of a flammable or explosive gas mixture. Proper device installation, operation, and maintenance is required to ensure safe and effective operation.*

#### **APPLICATION**

The AutroPath HC600 is an open path infrared gas detection system that provides continuous monitoring of combustible hydrocarbon gas concentrations in the range of 0 to 5 LFL-meters, over a distance of 5 to 120 meters. Standard system outputs include an electrically isolated/non-isolated 4-20 mA dc current output, with HART communication and RS-485 MODBUS communication. Alarm and fault relays are available as an option.

The system consists of two stainless steel modules — a transmitter and a receiver, along with mounting fixture hardware. Both modules are powered from an external 24 volt DC supply. The receiver provides the measurement signal outputs, and is furnished with an onboard "status indication" LED and an internal magnetic calibration switch. The transmitter houses dual xenon flashlamps. Both modules are installed at approximately the same elevation and must be aligned to point directly at one another. No direct electrical interconnection between the two modules is required.

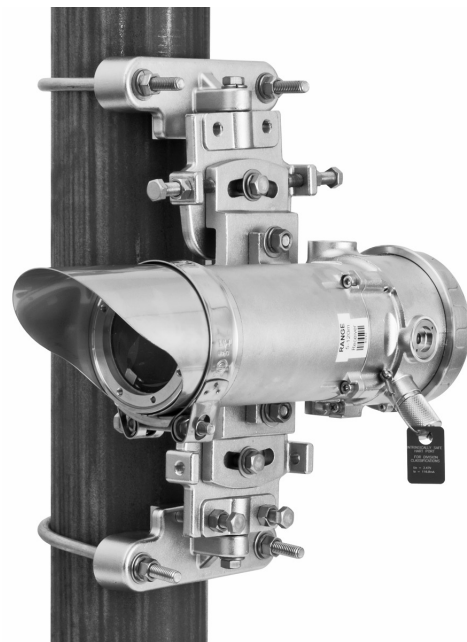

The AutroPath is ideal for use in harsh outdoor environments and is certified explosion-proof for use in Class I, Division 1 and Division 2 hazardous areas. It can be used as a stand-alone detector, or as part of a larger facility protection system using other Autronica equipment such as AutoSafe Integrated Fire and Gas system.

# OPERATION OVERVIEW

## THEORY OF OPERATION

The HC600 transmitter module illuminates a direct linear path ending at the HC600 receiver module. As flammable hydrocarbon gases intersect the light beam between the two modules, certain IR wavelengths are absorbed by the gas, while other IR wavelengths are not. The amount of IR absorption is determined by the concentration of the hydrocarbon gas. A pair of optical detectors and associated electronics located in the receiver module measure the absorption. The change in intensity of the absorbed light (active signal) is measured relative to the intensity of light at a non-absorbed wavelength (reference signal). The microprocessor computes the gas concentration and converts the value into a 4 to 20 milliampere current output signal, which is then communicated to external control and annunciation systems. No filter wheel motors or other moving parts are utilized in either module.

The output signal is a 4-20 mA signal, which corresponds to 0-5 LFL-meters. To better understand the concept of LFL-meters, refer to Figure 1, which shows how three gas clouds of different size and concentration would produce the same output of 1 LFL-meter by the HC600 gas detection system.

### NOTE

*The system must be configured for less than 60% of the full scale measuring range, with consideration to the accepted gas cloud size and concentration.*

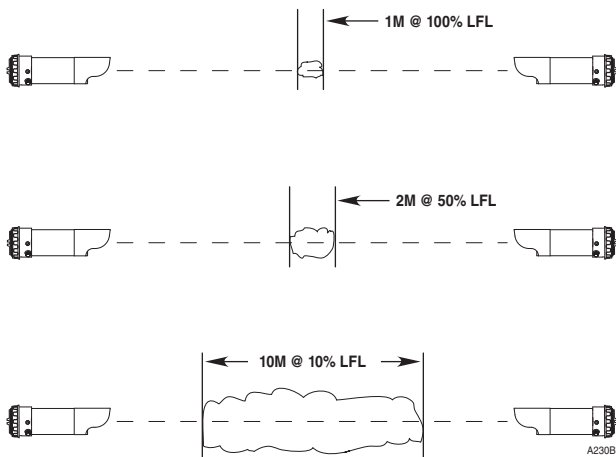

HC600 OUTPUT EQUALS 1 LFL-M IN ALL THREE SCENARIOS

Figure 1—Detector Response to Three Gas Clouds of Different Size and Concentration

## DETECTABLE GASES

HC600 is capable of detecting most hydrocarbon gases and vapors including methane, ethane, propane, butane, and propylene. Gas type and other operational parameters are selected via digital communications. The factory calibrated setting is methane.

## STANDARD OUTPUT

A 4 to 20 mA current loop corresponding to 0 to 5 LFL-meters is provided for connection to analog input devices such as gas controllers, logic controllers, or distributed control systems (DCS). To convert the mA reading to LFL-meters, use the following formula:

$$\frac{\text{mA Reading} - 4}{16} \times 5 = \text{LFL-meters}$$

## OPTIONAL RELAYS

The HC600 can be furnished with a factory installed relay output board that provides two programmable alarm relay outputs and one fault relay output. All relays are sealed and provide form C (NO/NC) contacts. The high and low alarm relays are programmable and can be set for latching or non-latching operation. **When the high alarm relay is configured for non-latching operation, the detector must be connected to an auxiliary system that provides the latching function.** The low alarm cannot be set above the high alarm threshold. Alarm configuration can be done with the HART or MODBUS interface. The onboard multi-color LED indicates a LOW alarm condition via a flashing red color, and a HIGH alarm condition via a steady red color. The HC600 internal magnetic switch or HART Field Communicator can be used to reset latched alarms. A short-duration magnetic switch activation of 1 second will reset latched alarms. Holding the magnetic switch closed for 2 seconds will start the calibration sequence. The external calibration line will not reset latched alarm relays.

When the optional relay output board is installed, the HC600 receiver is certified for EEx d operation.

### NOTE

*Refer to "Alarm Relays" in the Specifications section of this manual for important information regarding alarm relays.*

## COMMUNICATION

The standard HC600 system provides an analog 4-20 mA signal output, with HART and RS-485 MODBUS serial communication from the receiver module.

## RECORDING CAPABILITY

Non-volatile memory is provided to save the 10 most recent calibrations, alarm/fault events, and minimum/maximum operating temperature history. A real time clock is provided to record operating service time and to time stamp events. This information is accessible using HART and MODBUS communication.

## DETECTION RANGE

The standard HC600 system can cover a range of 5 to 120 meters.

## OPERATION

### MODULE IDENTIFICATION

While the HC600 transmitter and receiver modules appear physically identical, each module is labeled as “transmitter” or “receiver” on the enclosure. The physical mounting requirements for both modules are generally identical. However, there are functional and electrical characteristic differences as identified in Table 1.

Table 1—Functional and Electrical Comparison of Transmitter and Receiver

Characteristic	Transmitter (Tx)	Receiver (Rx)
Functional Description	Contains primary and backup xenon flashlamps, and generates optical energy to enable hydrocarbon detection.	Contains opto-electronics, signal processing and output drivers, and diagnostic electronics.
Power Consumption	5.0 watts nominal @ 24 Vdc. 5.8 watts peak @ 24 Vdc.	6.0 watts nominal @ 24 Vdc (without relays). 6.4 watts nominal @ 24 Vdc (with relays).
Electrical Connections	2 power connections only. (+24 Vdc and -24 Vdc).	From 3-7 connections depending upon specific configuration (separate power and signal cables recommended).
Onboard HART Communication Port	N/A	Connection to handheld HART communicator for system setup, commissioning, and diagnostics.
Onboard LED Indicator	Indicates normal, fault, and backup lamp operation status. Green indicates normal operation. Yellow indicates operation in “back-up lamp” mode or other fault condition.	Indicates normal, alarm, fault, and calibration status. Green indicates normal operation. Blinking red indicates low gas alarm condition. Steady red indicates high gas alarm condition. Yellow indicates operation in “back-up lamp” mode or system fault. Calibration status is indicated by a steady red indication after Calibration command. LED operation for fault status is non-latching. LED operation for gas alarms is configurable for latching/non-latching.
Magnetic Calibration Switch (See Figure 2 for switch location.)	Momentary activation overrides back-up lamp fault flash coding sequence, permitting normal receiver operation with back-up lamp.	Momentary activation provides reset function for latched alarm outputs. Activation for longer than 2 seconds will initiate zero calibration.
Factory Default Settings	No programmable options	Factory calibrated for methane, 0-5 LFL-meters full scale. See Table 2 for receiver factory default settings. HART communication is required to change the factory default settings.

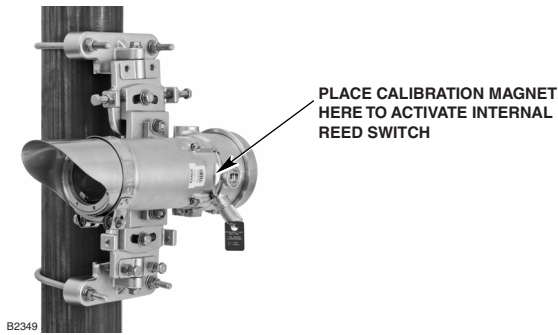

Figure 2—Location of Receiver's Internal Magnetic Switch

## OPERATING MODES

The HC600 has four operating modes: warm-up, normal, alignment and calibrate.

### Warm-up

Warm-up mode is entered upon application of 24 Vdc operating power. During warm-up, the 4-20 mA current loop output will indicate warm-up, the indicating LED is yellow, and the alarm outputs are disabled. The warm-up mode lasts nominally two minutes after power-up.

### Normal

After warm-up mode is completed, the device automatically enters the Normal mode, and all analog and alarm outputs are enabled.

### Alignment

The HC600 modules must be properly aligned before normal operation is attained. There are two alignment procedures:

1. Basic Alignment requires the HC600 Alignment Kit.
2. Fine Alignment requires the HC600 Alignment Kit and a handheld HART Communicator.

Table 2—Factory Default Settings

	Default	Configurable Options
Gas Type	Methane	Ethane, Propane Butane, Propylene Special
Measurement Range (LFL-M)	0-5	0-2, 0-5
Low Alarm Threshold (LFL-M)	1	0.25 to 3
High Alarm Threshold (LFL-M)	2	1 to 3
Beam Block Delay	60 Seconds	3600 Seconds
Fault Mode	OPGD-Rx	PIR9400, User Defined

### Calibrate

After alignment is completed, zero calibration is required. Span calibration of the HC600 is normally not required; however, the user has the option to verify proper calibration or to perform calibration procedures if necessary. It is recommended that the zero calibration procedure be performed annually. Refer to the "Calibration" section in this manual for details.

### 4-20 MA CURRENT LOOP OUTPUT

HC600 provides a linear current loop output that is proportional to the detected gas level. Fault and calibration status are also indicated by this output.

The factory default for full-scale 5 LFL-meters output is 20 mA. MODBUS interfaces also have the ability to calibrate the 4 mA and 20 mA levels.



## FAULT INDICATION

Faults and status conditions are indicated using the 4-20 mA analog signal output. Refer to Table 3. Signaling modes include two predefined and one user defined mode. OPGD-Rx mode (default) is available as well as a user defined mode for third party compatibility.

Table 3—Detector Status Conditions Indicated by Current Level

Status	4-20 mA Level ( $\pm 0.1$ )	
	OPGD-Rx (Default)	PIR9400
Normal Gas: -0.5 to 5 LFL-M	2.4 to 20.0	2.4 to 20.0
Warmup	1.0	1.0
Zero Calibration	1.0	2.2
Calibration Fault	1.0	1.6
Beam Block	2.0	1.0
Tx Lamp Fault*	3.0	2.4
Calibrate Active at Startup	1.0	0.6
EE Error	1.0	1.2
Ref. ADC Saturated	1.0	0.2
Active ADC Saturated	1.0	0.4
24 VDC Fault	1.0	0.8
Zero Drift	1.0	2.4
Flash CRC Error	1.0	1.2
RAM Error	1.0	1.2
Over Range	20.4	20.4

\*Device is still functional. Gas overrides this indication.

## TRANSMITTER LAMP OPERATION

Dual xenon lamps illuminate the linear detection path from the transmitter to the receiver. Should excessive degradation of the light intensity occur, the transmitter automatically increases the light output of the bulbs. The receiver recognizes this condition by the change in flash pulse coding and responds by initiating a "Tx Lamp Fault" warning signal. Total system operation is maintained, with no loss of sensitivity or detection performance.

In this mode of operation, the following occur:

1. The indicator LED turns yellow on both the transmitter and the receiver.
2. HART and MODBUS communication warn of a "Tx Lamp Fault" condition.
3. The 4-20 mA signal drops from a normal 4 mA to 3.0 mA in OPGD-Rx mode (default) or 2.4 mA in PIR9400 mode. The analog output value is overridden if the gas level exceeds 0.5 LFL-meters. All gas alarm signals will occur as normal.

Service should be arranged as soon as possible. A new transmitter module should be installed.

### NOTE

*The "Tx Lamp Fault" condition indicated by the 4-20 mA output can be acknowledged by applying a magnet to the transmitter module for at least 5 seconds. The coded flash sequence will then return to normal, which causes the 4-20 mA signal at the receiver module to also return to normal. The indicator LED on the receiver will return to green, however, the indicator LED on the transmitter will remain yellow to annunciate the lamp fault condition. This condition will continue until power to the transmitter unit is cycled or the lamps no longer operate.*

## SPECIFICATIONS

### INPUT VOLTAGE (Both Modules)—

24 Vdc nominal. Operating range is 18 to 30 Vdc.  
Ripple cannot exceed 0.5 volts P-P.

### POWER CONSUMPTION (Per Module)—

#### Transmitter

5.0 watts nominal @ 24 Vdc, 6.9 watts @ 30 Vdc.  
5.8 watts peak @ 24 Vdc, 7.5 watts peak @ 30 Vdc.

#### Receiver Without Relays

6.0 watts nominal @ 24 Vdc, 7.6 watts nominal @ 30 Vdc.

#### Receiver With Relays

6.4 watts nominal @ 24 Vdc, 8.0 watts nominal @ 30 Vdc.

### TRANSMITTER LAMPS

Two xenon flashlamps, field-replaceable module.

### WARMUP TIME—

1 minute for transmitter. 30 seconds for receiver from power-up when correctly aligned.

### CURRENT OUTPUT—

Linear 4-20 mA (isolated/non-isolated) rated at 600 ohms maximum loop resistance @ 24 Vdc operating voltage.

### RELAY OUTPUTS (Optional)—

Available on Ex d approved models only.

### ALARM RELAYS—

Low and High

Form C Type (NO/NC). De-Energized during Normal mode, Energized on Alarm.

Contact Rating: 5 amperes at 30 VDC.

Programmable for Latching or Non-Latching Operation.

Low Alarm: 0.25 to 3 LFL-meters  
(default = 1 LFL-meters, Non-latching).

High Alarm: 1 to 3 LFL-meters  
(default = 2 LFL-meters, Non-latching).

Alarm relays are programmable using HART or MODBUS communication.

## CAUTION

*When the HC600 Gas Detector is used in conjunction with an appropriate certified Control Unit and configured for a non-latching high alarm, the control unit must **always** latch and require a deliberate manual action to clear a high gas alarm. When used as a stand alone device, the high alarm must always be programmed for latching operation.*

### FAULT RELAY—

Form C Type (NO/NC). Energized during Normal mode, De-Energized on Fault or loss of power.

Contact Rating: 5 amperes at 30 VDC.

Non-Latching Operation only — not programmable.

### VISUAL STATUS INDICATOR—

Multi-color LED – Transmitter:

Green = Power on / OK

Yellow = Fault / warmup.

Multi-color LED – Receiver:

Red = Low alarm, high alarm, or calibration

Green = Power on / OK

Yellow = Fault / warmup.

### ALARM RELAY SETPOINT RANGE—

Low Alarm: 0.25 to 3 LFL-meters (default = 1)

High Alarm: 1 to 3 LFL-meters (default = 2).

Alarm setpoint is programmable using HART or MODBUS communication.

### DETECTION RANGE—

5 to 120 meters.

### CALIBRATION—

HC600 systems are span calibrated for methane at the factory. Span calibration in the field is not required.

Zero calibration is accomplished in the field by one of the following methods:

- On-board magnetic reed switch
- MODBUS communication
- HART communication

### RESPONSE TIME—

Refer to the appropriate Appendix for details.

**ACCURACY—**

Refer to the appropriate Appendix for details.

**NOTE**

*Misalignment will cause the manufacturer stated Accuracy limits to increase, but remain within the limits of EN 50241-1, -2, EN 60079-29-4, and IEC 60079-29-4.*

**TEMPERATURE RANGE—**

Operating: -55°C to +60°C (-67°F to +140°F)

Storage: -55°C to +85°C (-67°F to +185°F)

Hazardous Locations: Refer to the appropriate Appendix for correct ambient temperature range:

Appendix A - ATEX

Appendix B - IECEx

**HUMIDITY—**

5 to 99% relative humidity; designed for outdoor applications.

**OPERATING PRESSURE—**

91.5 - 105.5 kPa non-compensated.

**MEASUREMENT RANGE—**

0-5 LFL-meters.

**INTERFERENCE RESISTANCE—**

Immune to sun and flare radiation, tested to 800 ±50 W/m<sup>2</sup> ≥ 3° to optical axis and common contaminants.

**SELF-DIAGNOSTIC TEST—**

Fail-Safe operation ensured by performing all critical tests once per second.

**MODULE HOUSING MATERIAL—**

316 stainless steel (CF8M).

**CONDUIT ENTRY OPTIONS—**

Two entries, 3/4 inch NPT or 25 mm.

**HART COMMUNICATION PORT—**

An intrinsically safe port is provided on the receiver for connecting a Rosemount/Emerson HART Communicator.

- Maximum separation distance between receiver and communicator is 610 meters.

**OPTICS PROTECTION—**

Stainless steel brow provides a degree of protection against windblown dirt and rain. Heated optics mitigate against ice and dew formation.

**WIRING—**

Field wiring screw terminals are UL/CSA rated for up to 14 AWG shielded wire, and are DIN/VDE rated for 2.5 mm<sup>2</sup> wire. Screw terminal required torque range is 3.5–4.4 lb.-in. (0.4-0.5 N·m). Receiver can be wired using 3 or 4 wires. Transmitter requires two wires (power only).

**CERTIFICATION—**

For complete approval details, refer to the appropriate Appendix:



Appendix A - ATEX

Appendix B - IECEx

Appendix C - Other Approvals

**DIMENSIONS—**

**Module**

Length: 11.5 inches (29 cm)  
Diameter: 3.5 inches (9 cm) nominal  
4.5 inches (11 cm) maximum

**Mounting Plate**

Height: 14.5 inches (37 cm)  
Width: 6.5 inches (16 cm)  
Designed to attach to a 4 inch nominal diameter pipe.

Refer to Figure 3 for mounted dimensions.

**SHIPPING WEIGHT—**

Transmitter or receiver (replacement):  
30 pounds (14 kg)  
Transmitter and receiver with mounting hardware:  
75 pounds (34 kg)

**WARRANTY—**

2 year limited warranty from date of manufacture.

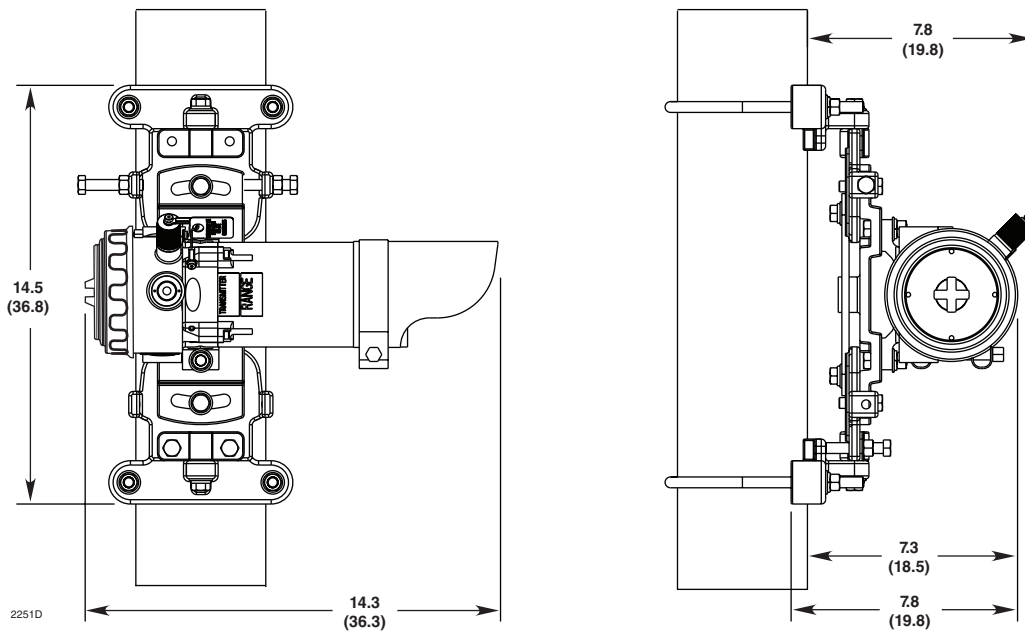

Figure 3—Mounted Dimensions of HC600 in Inches (cm)

## IMPORTANT SAFETY NOTES

### CAUTION

*The wiring procedures in this manual are intended to ensure proper functioning of the system under normal conditions. However, because of the many variations in wiring codes and regulations, total compliance to these ordinances cannot be guaranteed. Be certain that all wiring complies with the NEC as well as all local ordinances. If in doubt, consult the authority having jurisdiction before wiring the system. Installation must be done by a properly trained person.*

### CAUTION

*This product has been tested and approved for use in hazardous areas. However, it must be properly installed and used only under the conditions specified within this manual and the specific approval certificates. Any device modification, improper installation, or use in a faulty or incomplete configuration will render warranty and product certifications invalid.*

### CAUTION

*The system contains no user serviceable internal components. Service or repair should never be attempted by the user. Device repair should be performed only by the manufacturer or trained service personnel.*

### LIABILITIES

*The manufacturer's warranty for this product is void, and all liability for proper function of the system is irrevocably transferred to the owner or operator in the event that the device is serviced or repaired by personnel not employed or authorized by Autronica Fire and Security, or if the system is used in a manner not conforming to its intended use.*

### CAUTION

*Observe precautions for handling electrostatic sensitive devices.*

### NOTE

*The AutoPath HC600 is intended for detection of hydrocarbon vapors only. The device will not detect hydrogen gas.*

### NOTE

*The terminal compartment for HC600 without relays is designed for either an increased safety "e" termination or a flameproof "d" termination of the supply cable. If a flameproof connection is chosen, then an ATEX certified cable entry device must be used. The HC600 with relays requires Ex d cable entry devices only.*

## INSTALLATION

### IDENTIFICATION OF VAPOR(S) TO BE DETECTED

It is necessary to identify the flammable vapor(s) of interest at the job site in order to determine the proper calibration gas setting for HC600. In addition, the physical and fire hazard properties of the vapor, such as vapor density and flashpoint should be identified and used to assist in selecting the optimum detector mounting locations within the area. The detector must be installed by qualified personnel only, following local electrical equipment installation practices.

### SYSTEM LOCATION CONSIDERATIONS

The HC600 system is designed for installation in hazardous industrial areas. Each module is normally installed using a solid vertical steel post or flat surface mounting adapter to support the weight of the module. The modules must be strategically located so that the hydrocarbon vapor(s) to be detected will intersect the light beam generated by the transmitter module. Dispersion characteristics and behavior of the vapor cloud resulting from a gas leak can be difficult to estimate due to the significant number of variables that exist at different applications. Identification of expected gas leakage source(s), leak scenario identification, and onsite leak simulation are the steps generally recommended to provide the most accurate means of identifying optimum system installation locations.

In all cases, the beam path and surrounding area should be kept free of obstructions that could block the infrared beam or hinder the free movement of air within the area. A clear beam path of 20 CM diameter or greater is required. The system is immune to the effects of exposure to both direct and reflected sunlight.

Avoid installation in areas with obstructions such as steam vents and plumes, smoke stacks and chimneys, walkways and personnel areas, splash and sprayed water, parking, loading, cranes, vehicle-related areas such as bus stops, road junctions, and vegetation such as trees, shrubs, grass etc.

Autronica Field Service Engineering group routinely provides job site application surveys and analysis for customers, and their services are highly recommended if guidance on optimum installation locations is required. Additional guidance on the positioning of gas detectors for optimum coverage is contained in BS6959 and other national codes. Consult these codes of practice when determining where detectors are to be located.

Consideration of the following system location guidelines is also recommended:

### **LED Visibility**

Select a mounting orientation where the AutoPath HC600 status indication LED is visible to personnel within the area.

### **Module Separation Distance**

The transmitter and receiver modules must be installed directly facing each other across the area to be protected. Physical obstructions in the direct line of sight between the modules are not permitted. The overall line of sight distance between the modules must not fall outside the specified operating distance range (refer to "Specifications" for details).

### **Multiple System Installations**

If multiple HC600 systems are to be installed, ensure that each receiver can view only the intended transmitter.

### **System Mounting Elevation**

In all cases, the modules should be installed at the same elevation above grade to ensure that alignment capability and foul weather performance are not compromised. For detection of lighter than air vapors such as methane, installation of modules at approximately 2 meters above grade minimizes typical beam block conditions due to human activities, while enabling satisfactory detection capability. For detection of heavier than air vapors, installation of detectors below the expected leakage source is generally recommended unless nuisance beam blocks will occur at an unacceptable rate. In this case, identification and analysis of application specific conditions should be completed to determine the optimum installation elevation.

### **Sources of Heavy Contamination**

Avoid locations where high levels of contaminants will persistently be blown onto the detector windows. Potential sources of heavy contamination include generator / turbine exhausts, flarestacks, drilling equipment, process vents / chimneys, etc. If sources of heavy contamination cannot be avoided, consider fitting extra shielding and/or providing good access for routine cleaning.

### **Snow and Ice in Ambients Below –20°C**

The heated optics on both modules will melt snow or ice on the windows in ambient temperatures down to approximately –20°C. Below this temperature, snow or ice blown onto the window will not be melted until the ambient temperature rises. If long-term outdoor operation in very cold climates is intended, extra shielding / covers are recommended to prevent accumulation of snow and ice on the windows.

### **Deluge and Flooding**

The modules are rated IP66/IP67 and will not be damaged by occasional deluge or flooding. However, during such an event, the unit will completely lose its IR signal and will enter the "Beam-Block / Fault" state. In addition, when the deluge / flooding subsides, there is the possibility that contaminants will be left on the windows. Install the modules away from areas prone to deluge or flooding.

### **Areas Prone to Subsidence and Settling**

Avoid installation of the modules in areas where problems with subsidence, settling or thawing of permafrost can occur or cause significant movement. If such locations cannot be avoided, the foundations of the mounting structure should be engineered to minimize any angular movements between the receiver and transmitter.

### **Areas Prone to Earthquakes**

In the event of an earthquake, there is a chance that the modules will become misaligned with respect to each other. As long as the modules do not suffer from direct mechanical impact damage during an earthquake, they should remain undamaged by such events. After an earthquake, it is recommended that the system alignment be checked. Anti-vibration mounts are unlikely to be of any benefit and are not recommended.

### **Misalignment by Accidental Impact**

Locations where there is a significant likelihood of equipment, personnel or moving objects accidentally knocking the modules out of alignment should be avoided where possible. If such locations cannot be avoided, measures including improved mechanical protection and warning notices should be considered.

## MODULE MOUNTING RECOMMENDATIONS

HC600 modules **must** be affixed to a solid, non-vibrating structure capable of supporting a minimum of 100 lbs (46 kg), located within the system's rated separation distance.

A building wall, a heavy steel I-beam, or nearly any type of masonry typically provides the most rigid mounting surface available. However, avoid the use of wood structures or supports if the possibility of warping exists.

When using a vertical post, the post **must** be absolutely stable and without vibration. Square stock pole is recommended. Mounting height should not exceed 3 meters.

The post can be set into the ground or attached to a secure surface. If a post is set into the ground, the portion below grade should be set in concrete at least 1 meter deep.

## IMPORTANT

*In all cases, consider whether additional bracing or support is needed to ensure the structural integrity of the module installation. See Figure 4. Remember that accurate module alignment is essential for proper performance of an open path gas detection system, and **even a small amount of movement can have a detrimental effect on alignment.** This is especially true for installations with significant module separation distances.*

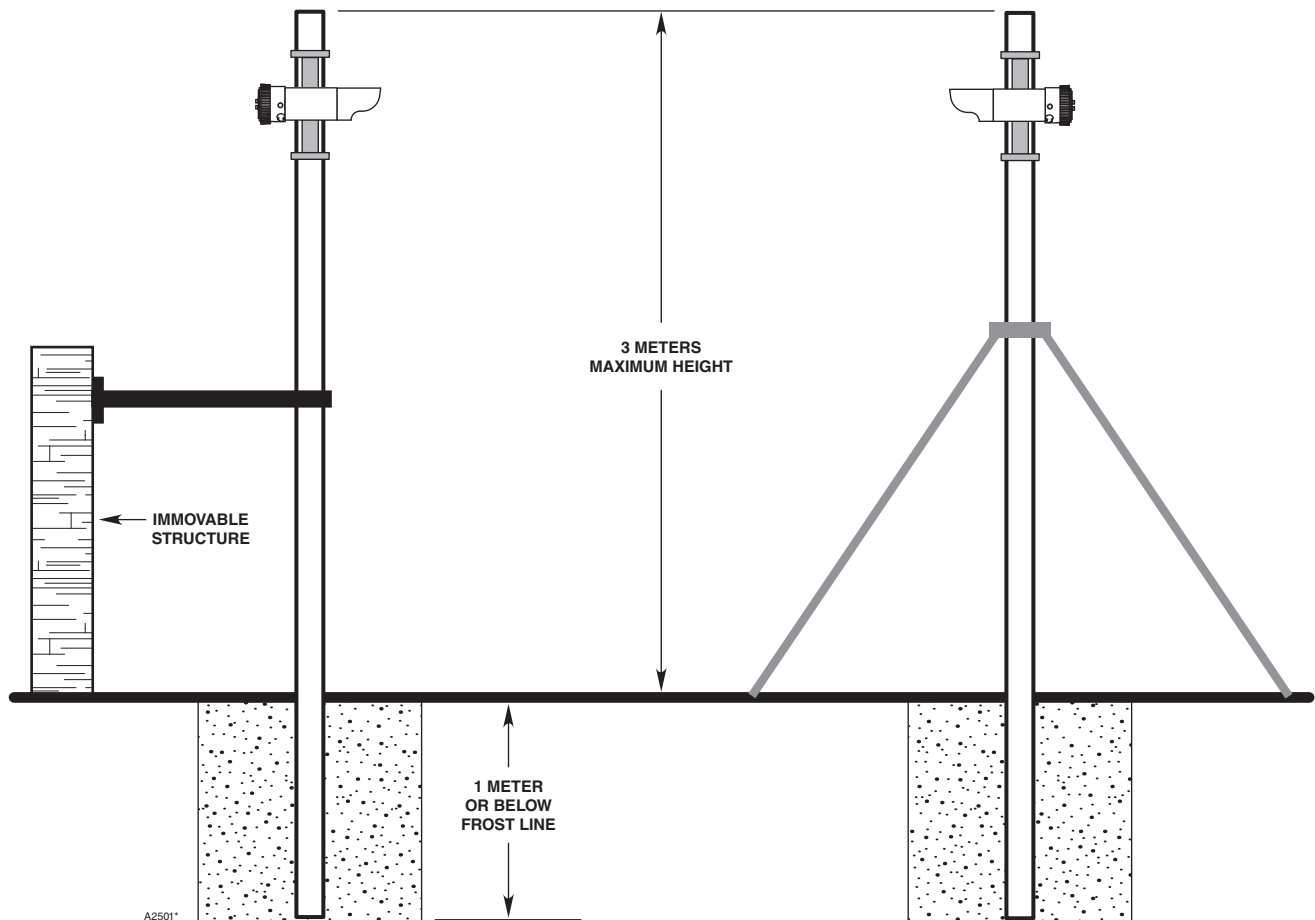

NOTE: INSTALLATIONS NEAR MAXIMUM HEIGHT TYPICALLY REQUIRE BRACING TO ENSURE NO MOVEMENT OF THE HC600 DETECTOR.

Figure 4—Example of Bracing Added to Vertical Mounting Poles for Increased Robustness of HC600 Installation



Module mounting options include:

- A vertical post with a nominal outside diameter of 4.5" (11.43 cm). Acceptable outside diameter range is 4.0 to 5.0 inches. See Figure 5.
- For flat surface mounting, refer to Figure 6.

### Mounting Sequence

1. Attach the HC600 module to the pan-tilt mounting plate and tighten the HC600 mounting bolts to 20 lb.-ft. minimum.
2. Install the lower mounting bracket.
3. Place the pan-tilt mounting plate on the lower bracket and install the upper mounting bracket. Tighten the mounting hardware to 20 lb.-ft. minimum. Tighten the alignment bolts/nuts hand tight only.

#### NOTE

*Anti-seize material (provided) must be applied to the U-bolt threads at the time of installation to prevent galling.*

### 24 VDC POWER SUPPLY REQUIREMENTS

Calculate the total gas detection system power consumption rate in watts from cold start-up. Select a power supply with adequate capability for the calculated load. Ensure that the selected power supply provides regulated and filtered 24 Vdc power for the entire system. If a back-up power system is required,

a float-type battery charging system is recommended. If an existing source of 24 Vdc power is being utilized, verify that system requirements are met.

#### NOTE

*If disconnection of power is required, separate disconnect capability must be provided.*

### WIRING CABLE REQUIREMENTS

Always use proper cabling type and diameter for input power as well as output signal wiring. 14 to 18 AWG shielded stranded copper wire is recommended.

Always install a properly sized master power fuse or breaker on the system power circuit.

#### NOTE

*The use of shielded cable in conduit or shielded armored cable is required for ATEX conformance. In applications where the wiring is installed in conduit, dedicated conduit is recommended. Avoid low frequency, high voltage, and non-signaling conductors to prevent nuisance EMI problems.*

#### CAUTION

*The use of proper conduit installation techniques, breathers, glands, and seals is required to prevent water ingress and/or maintain the explosion-proof rating.*

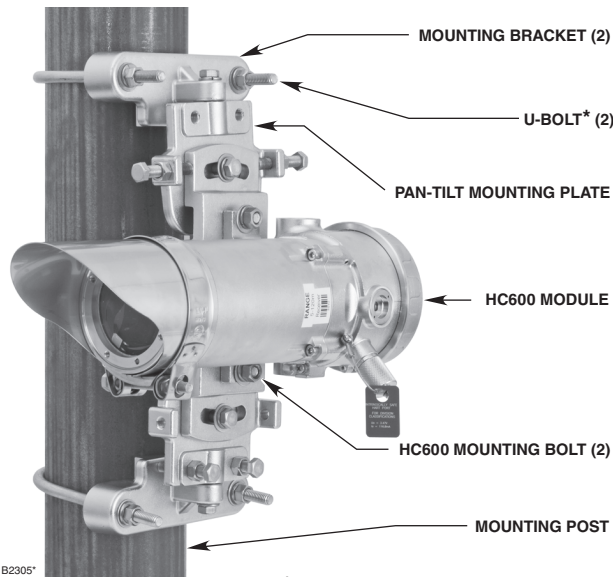

Figure 5—HC600 Gas Detector Mounted to Vertical Post

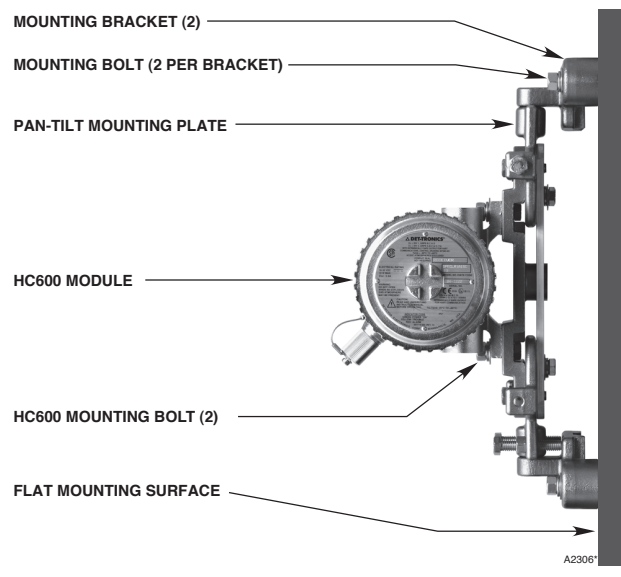

Figure 6—HC600 Gas Detector Mounted to Flat Surface



## POWER WIRING SIZE AND MAXIMUM LENGTH

1. To ensure proper operation, HC600 power terminals (terminals 1 and 2 for Rx and Tx) and 4-20 mA terminals (terminals 6 and 7 for Rx) must receive 18 Vdc minimum. 24 Vdc is recommended. Terminals 1 and 4, and terminals 2 and 5 on the HC600 Rx are internally connected (see wiring diagrams).
2. Always determine voltage drops that will occur to ensure that 24 Vdc is delivered to the HC600.
3. Normally, nothing smaller than 18 AWG (1.0 mm<sup>2</sup>) is recommended by Autronica for HC600 power cabling.

Wire size requirements are dependent upon power supply voltage and wire length.

The maximum distance between the HC600 detector and its power supply is determined by the maximum allowable voltage drop for the power wiring loop. If the voltage drop is exceeded, the device will not operate. To determine the maximum power loop voltage drop, subtract the minimum operating voltage for the device (18 Vdc) from the minimum output voltage of the power supply.

To determine the actual maximum wire length:

1. Divide the maximum allowable voltage drop by the maximum current draw of the HC600 (0.35 A),
2. Divide by the resistance of the wire (ohms/foot value available in wire manufacturer's specification data sheet),
3. Divide by 2.

For example: Consider an installation using 18 AWG wiring with a power supply providing 24 Vdc.

Power supply voltage = 24 Vdc,  
HC600 minimum operating voltage = 18 Vdc

$$24 - 18 = 6 \text{ Vdc}$$

Maximum Voltage Drop = 6  
Maximum Current = 0.35 A  
Wire Resistance in Ohms/Foot = 0.006523

$$6 \div 0.35 \div 0.006523 \div 2 = 1314 \text{ feet}$$

## OPTIONAL RELAYS

Optional relay contacts are “dry”, meaning that the installer must provide the voltage to the common terminal of the relay output.

AC voltage should not be switched directly using the HC600 relays. The use of an external relay is required if AC voltage must be switched by the HC600 relays.

In order to change alarm relay settings from the factory default settings, it is recommended to utilize a HART Field Communicator. Contact the factory for further assistance.

### NOTE

*Refer to “Alarm Relays” in the Specifications section of this manual for important information regarding alarm relays.*

The relay board must temporarily be removed from the HC600 termination compartment to connect the relay output field wiring cables. After the relay wiring is connected, re-install the relay board using the three captive screws. Refer to Figure 7.

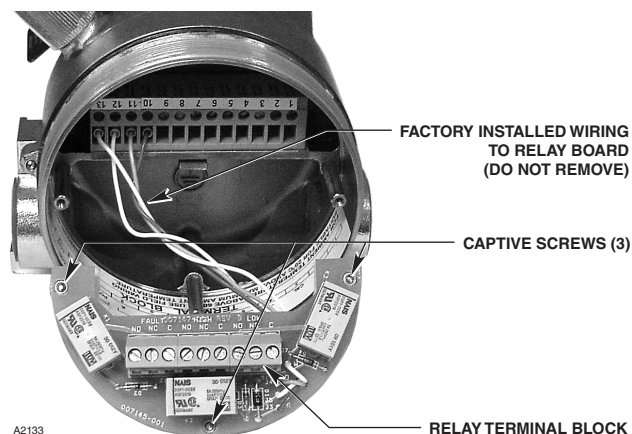

Figure 7—HC600 Wiring Termination Compartment with Optional Relay Board Removed

## WIRING PROCEDURE

For systems using conduit, modules must be wired using a short piece of suitable flexible conduit to allow optical alignment of the modules. Conductor insulation should be stripped off with a bare conductor length of 0.2 inch (5 mm) minimum and 0.7 inch (18 mm) maximum). AutoPath HC600 screw terminal torque range is 3.5–4.4 lb.-in. (0.4–0.5 N·m).

Cable shield, if used, should be properly terminated. If not terminated, clip the shield wire off short and insulate it within the detector housing to prevent the shield wire from accidentally contacting the detector housing or any other wire.

Figure 8 shows the wiring terminal strip located inside the detector's integral junction box.

Figure 9 shows the wiring terminal configuration for the HC600 transmitter. (The transmitter requires only operating power.)

Figure 10 shows the wiring terminal configuration for the HC600 receiver without relays.

Figure 11 shows the wiring terminal configuration for the HC600 receiver with relays.

Figures 12 through 15 show the 4 to 20 mA output of the HC600 receiver in various wiring schemes.

### NOTE

*The HC600 housing must be electrically connected to earth ground. A dedicated earth ground lug is provided for this purpose.*

### NOTE

*For proper HART communication, it is required that an analog signal loop resistance of 250 to 500 ohms be present at the receiver analog output terminals. See Figure 16 for benchtop test wiring. For HC600 systems using HART communication, the maximum wiring distance is 2,000 feet.*

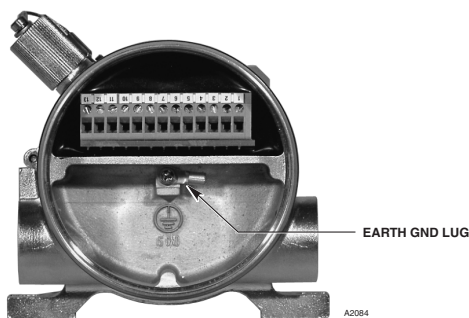

Figure 8—Terminal Strip Located Inside Wiring Compartment

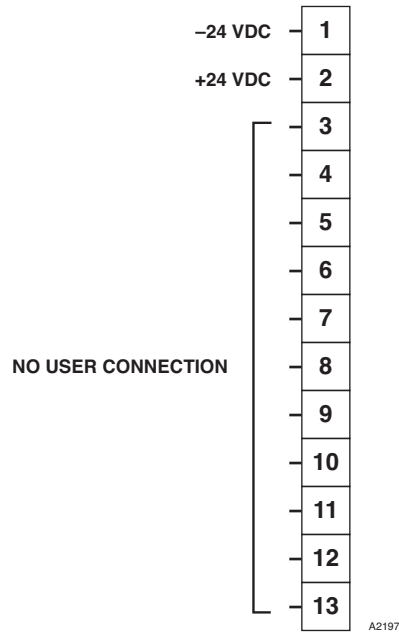

Figure 9—Transmitter Wiring Terminal Identification

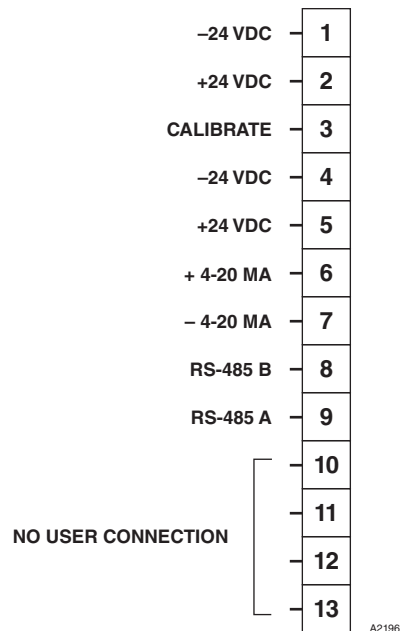

Figure 10—Wiring Terminal Identification for HC600 Receiver without Relays

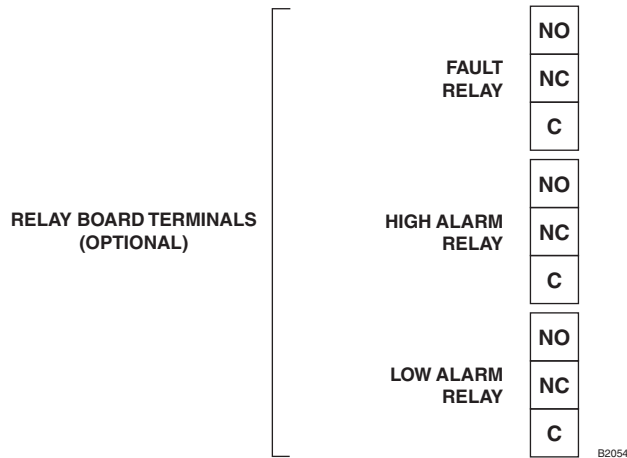
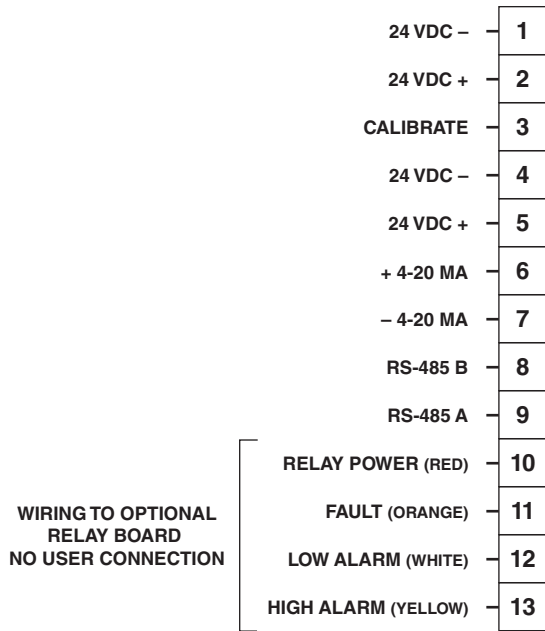
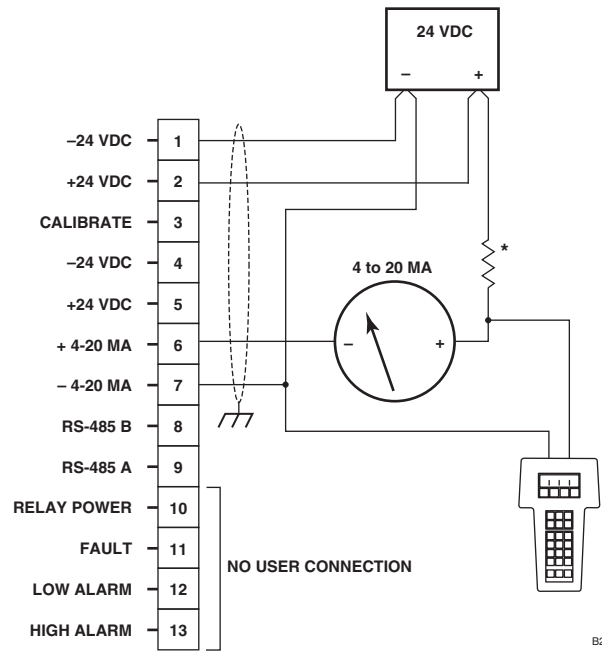

Figure 11—Wiring Terminal Identification for HC600 Receiver with Relays



B2050

\*TOTAL LOOP RESISTANCE = 250 OHMS MINIMUM, 600 OHMS MAXIMUM.

Figure 12—Detector Wired for Non-Isolated 4 to 20 ma Current Output (Sinking)

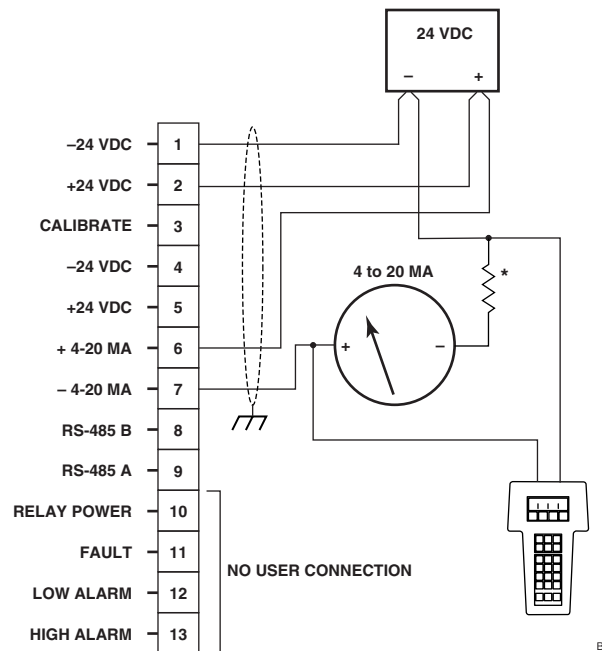

B2051

\*TOTAL LOOP RESISTANCE = 250 OHMS MINIMUM, 600 OHMS MAXIMUM.

Figure 13—Detector Wired for Non-Isolated 4 to 20 ma Current Output (Sourcing)

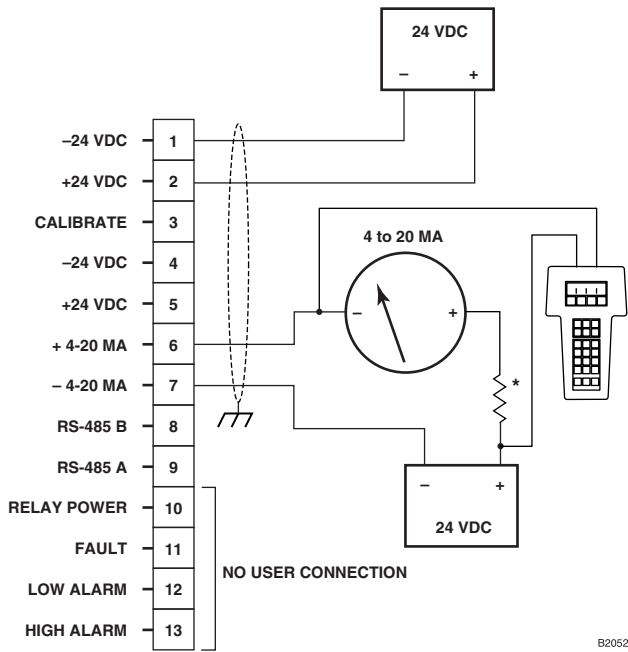

\*TOTAL LOOP RESISTANCE = 250 OHMS MINIMUM, 600 OHMS MAXIMUM.

Figure 14—Detector Wired for Isolated 4 to 20 ma Current Output (Sinking)

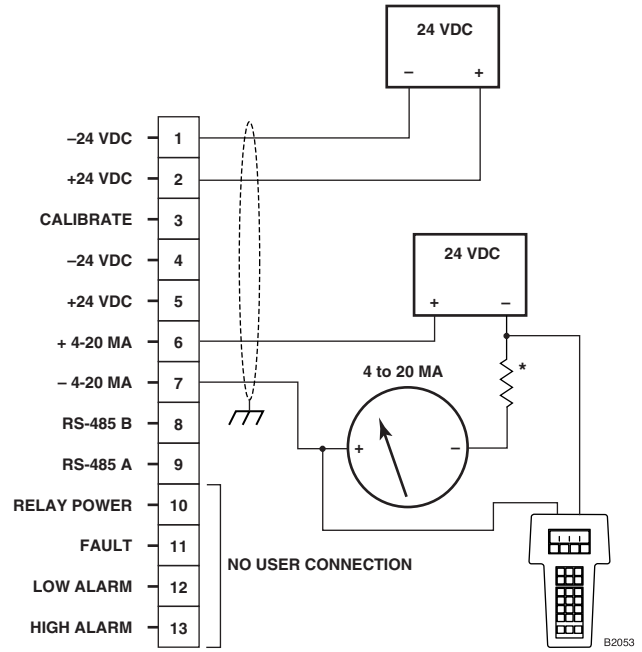

\*TOTAL LOOP RESISTANCE = 250 OHMS MINIMUM, 600 OHMS MAXIMUM.

Figure 15—Detector Wired for Isolated 4 to 20 ma Current Output (Sourcing)

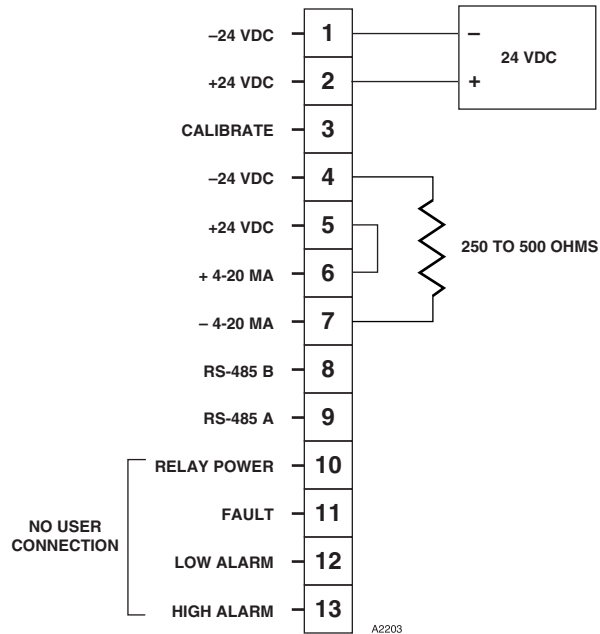

Figure 16—Wiring the HC600 for Benchtop Testing/Programming Using HART Protocol

## STARTUP

When the HC600 is installed and wired as described in the "Installation" section, it is ready for commissioning. If the application requires that specific changes be made to the factory settings, HART communication will be required.

### NOTE

*Ensure that alarm devices are bypassed during commissioning.*

### NOTE

*The safety function (gas input-to-actuation/notification) must always be verified upon completion of installation and/or modification.*

## ALIGNMENT

### OVERVIEW

The HC600 modules must be properly aligned before normal operation will be attained. Alignment consists of a basic alignment stage and a fine alignment stage:

1. **Basic Alignment Procedure.** This procedure requires the Telescope Alignment Kit p/n 116-009104-001. It does not require a handheld HART Field Communicator.
2. **Fine Alignment Procedure.** This procedure requires a handheld HART Field Communicator with the OPECL Device Descriptor (DD) software driver (refer to Appendix D). The fine alignment procedure is required whenever maximum optical signal strength is required.

### NOTE

*Basic Alignment must be successfully completed before attempting Fine Alignment.*

### NOTE

*Refer to the ATEX and IECEx Appendix for information regarding the effect of misalignment on system accuracy.*

### IMPORTANT

*Upon completion of system alignment, ensure that **ALL** bolts on the HC600 mounting bracket are properly tightened, including the two on the back side.*

## BASIC ALIGNMENT PROCEDURE

### Equipment Required

1. Properly installed and powered HC600 system (transmitter and receiver). Easy access to both modules is highly recommended.
2. Telescope Alignment Tool p/n 116-009104-001. The telescope alignment tool is recommended for use in commissioning all HC600 systems. The following instructions cover the use of the Telescope Alignment Tool.
3. Calibration Magnet.
4. For installations with module separation distances between 5 and 30 meters, the range reduction aperture kit (supplied) is required. Refer to "Aperture Kit for Short Range Applications" section in this manual for details.

Remove operating power from the HC600 Transmitter, and then complete the following steps:

1. Ensure that the system modules are located within the specified separation range and securely fixed to the support structures. Bypass all external gas alarm devices that are connected to the receiver outputs.
2. Ensure that the system modules are installed with their windows at approximately the same height above grade. Each module should be roughly aligned to face in the direction of the other module.
3. Loosen the locking nuts on the alignment adjuster bolts so that the bolts can be freely tightened or loosened for alignment purposes. Loosen, then hand-snug the two vertical alignment locking nuts. See Figure 17. At this point, the unit should be easily adjustable in the vertical and horizontal positions with little or no adjustment slop.
4. Hand-tighten all four adjustment bolts until the alignment plate is stabilized.
5. Loosen the brow assembly and slide it toward the rear of the module.

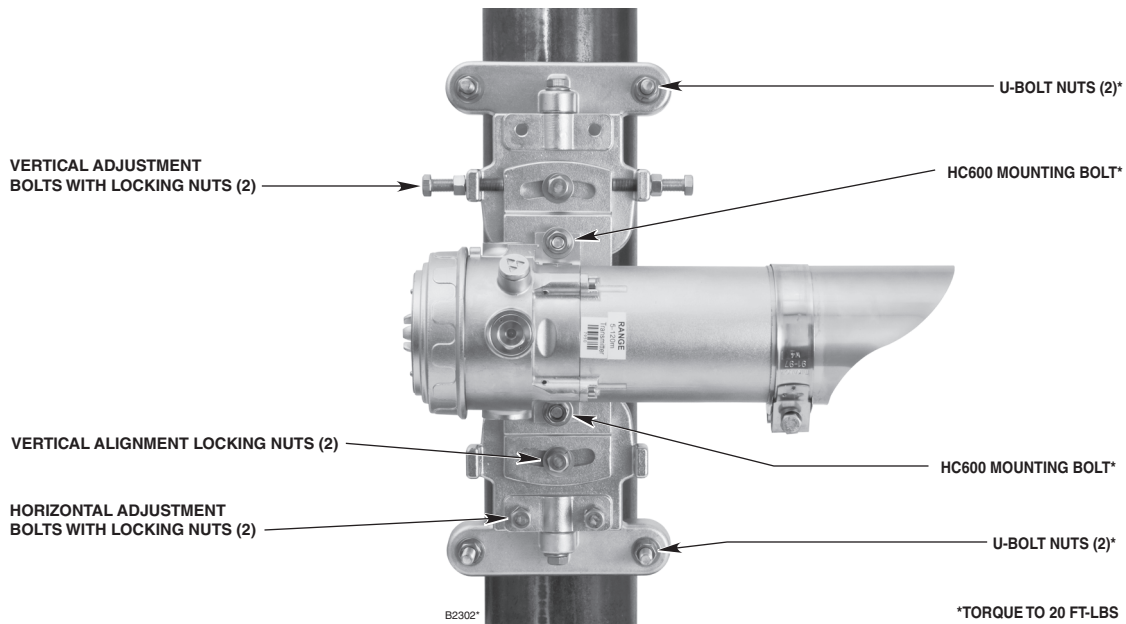

Figure 17—HC600 Mounting and Alignment Hardware (Transmitter Module Shown)

6. Install the Telescope Alignment Tool onto the receiver module by inserting the captive thumbscrews into the threaded holes on the faceplate. See Figure 18. Ensure that the telescope is properly attached, that the eyepiece is accessible, and that the thumbscrews are completely tightened.
7. Slowly adjust the receiver module up/down as required using the vertical adjustment bolts until the telescope cross hairs are centered as close as possible to dead center on the window of the transmitter module. Tighten the vertical alignment locking nuts so that no movement will occur.

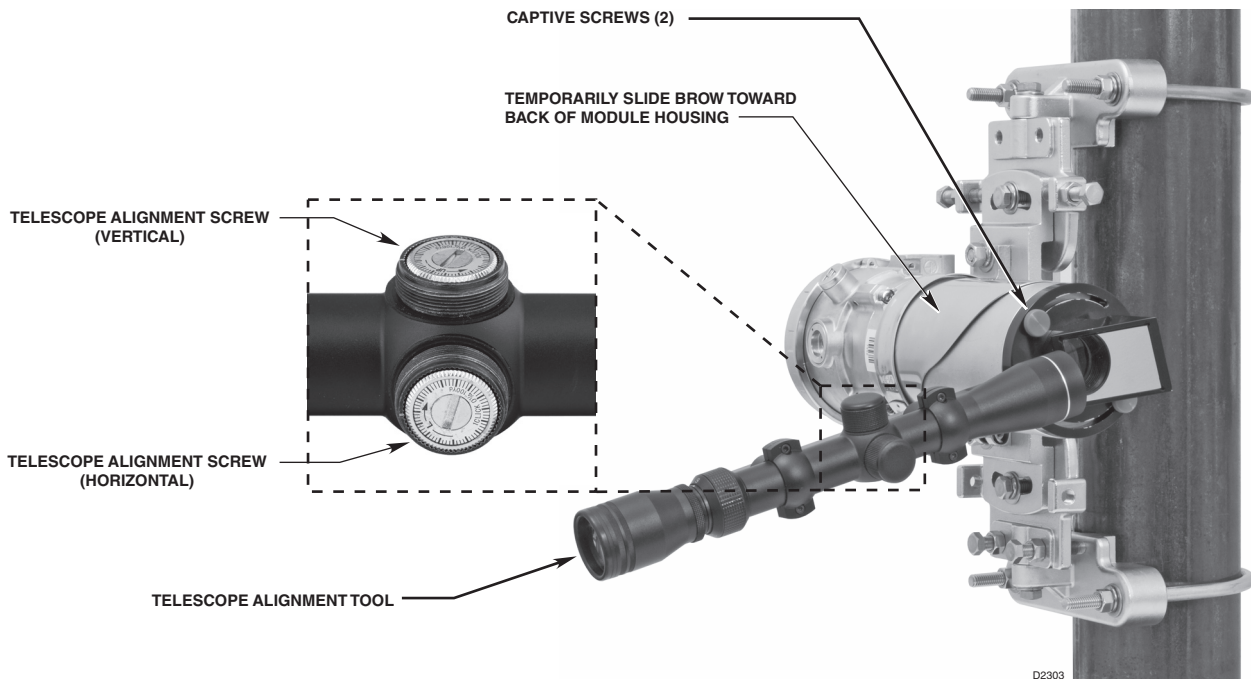

Figure 18— HC600 with Telescope Alignment Tool Installed (Transmitter Module Shown)

STEP 1: CENTER CROSS HAIRS ON TARGET USING ADJUSTMENT BOLTS ON MOUNTING PLATE (POSITION A).

STEP 2: ROTATE SCOPE 180°. ALIGNMENT ERROR CAUSES CROSS HAIRS TO MOVE TO POSITION B.

STEP 3: ADJUST ALIGNMENT SCREWS ON SCOPE TO PLACE CROSS HAIRS AT POSITION C.

STEP 4: ROTATE SCOPE 180° TO ORIGINAL POSITION.

STEP 5: REPEAT STEPS 1 TO 4 UNTIL THE UNIT IS CORRECTLY ALIGNED.

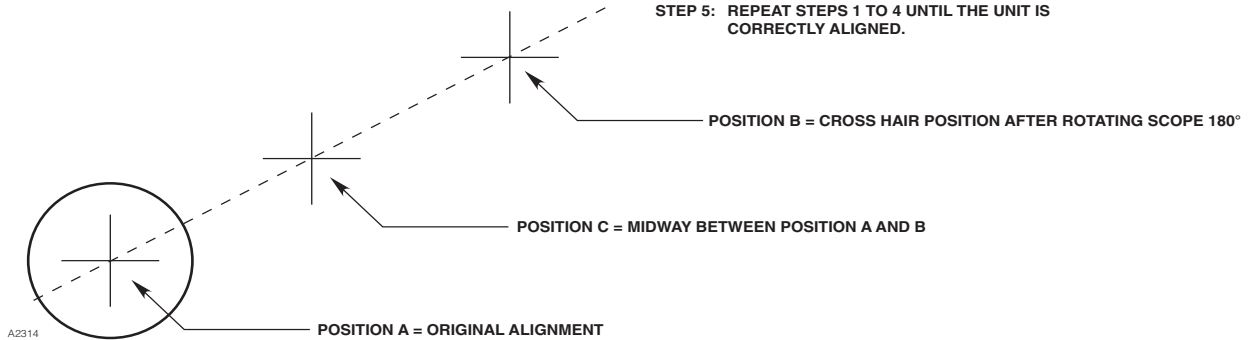

Figure 19—HC600 Alignment using the Telescope Alignment Tool

8. Slowly adjust the receiver module left/right as required using the horizontal adjustment bolts until the telescope cross hairs are centered as close as possible to dead center on the transmitter module window. Tighten the horizontal adjustment bolts and locking nuts so that no movement will occur.
9. Rotate the telescope alignment tool by 180° and verify that the cross hairs are in the same position. If the cross hairs are not in the same position, the telescope alignment screws must be adjusted as follows:
  - A. Adjust the telescope alignment screws until the cross hairs are midway between the original position (center of transmitter window) and the current position (after the scope was rotated 180°). See Figure 19.
  - B. Return the scope to its original position (rotate 180°) and repeat steps 7 through 9 until correct alignment is achieved.
10. Repeat the alignment procedure for the transmitter module (steps 6 to 9).
11. Re-check the receiver for correct alignment (steps 6 to 9) and adjust as needed.
12. Remove the Telescopic Alignment Tool and re-install the brow.
13. Bypass all external gas alarm devices that are connected to the receiver outputs, and then apply 24 Vdc power to the modules.
14. Upon completion of warm-up mode (approximately 2 minutes or less), the receiver may display either a green LED (normal mode) or a red LED (alarm mode). An alarm condition is not abnormal and will be cleared by performing a zero calibration.
15. For installations with module separation distances between 5 and 30 meters, install the appropriate aperture as described in the "Aperture Kit for Short Range Applications" section.
16. Perform a zero calibration. (Refer to "Zero Calibration" in the Calibration section of this manual.) Any faults or alarms that may be present as a result of the alignment process will be cleared.
17. When Basic Alignment and Zero Calibration have been successfully completed, a green LED should be displayed on the Rx module and the analog signal output level should be 4.0 milliamperes.

**NOTE**

*No further adjustments are required when the cross hairs are centered on the window with the scope in both 180° positions.*



## APERTURE KIT FOR SHORT RANGE APPLICATIONS

The Short Range Aperture Kit enables successful application of the HC600 gas detector at distances of approximately 5 to 30 meters. The kit is available in Delrin plastic (included with HC600 receivers) or optional stainless steel.

Two aperture sizes are provided:

- The 0.6" diameter (15 mm dia.) aperture is used for system separation distances of approximately 5 to 15 meters.
- The 1.2" diameter (30 mm dia.) aperture is used for system separation distances of approximately 15 to 30 meters.

### NOTE

*System separation distances greater than 30 meters should not require apertures.*

## Procedure for System Commissioning Using the Apertures

1. Align the HC600 system using the Basic Alignment procedure. At the completion of this alignment, the output signal at the Receiver will indicate a fault condition as a result of signal saturation (1.0 mA in OPGD-Rx mode or 0.2 / 0.4 mA in PIR9400 mode).
2. Attach the aperture to the front of the HC600 **Transmitter** module using the captive screws provided.

### NOTE

*The plastic model uses a one-piece aperture without holder. The stainless steel model uses a holder with interchangeable aperture inserts.*

Use the larger aperture for separation distances from 15 to 30 meters and the smaller aperture for distances from 5 to 15 meters. For distances around 15 meters, start with the larger aperture. An output signal of 2.4 mA or higher indicates proper detector operation (no fault condition). If the signal is still saturated (1.0 mA in OPGD-Rx mode or 0.2 / 0.4 mA in PIR9400 mode), the smaller aperture is required.

### NOTE

*System separation distances of 5 to 15 meters may require the use of both apertures. Place the 0.6" diameter aperture on the transmitter and the 1.2" diameter aperture on the receiver if a saturated signal exists.*

3. Perform a zero calibration. After performing the zero calibration, the Receiver module should display a normal condition (green LED) and a steady 4 mA output.

## RECOMMENDATIONS FOR USING THE HART FIELD COMMUNICATOR

- Ensure that the HART communicator is certified for use in classified areas.
- The HART communication device must include the HC600 (OPECL) device descriptor (DD) software menu. The use of HART communication devices without the proper DDs may establish generic mode HART communication, but will not enable proper operation with HC600. Refer to the HART Appendix for additional information.
- A minimum level of understanding with regard to the operation and navigation of the HART communicator is required. Please refer to the appropriate HART communicator instruction manual for basic operating instructions if required. Additional information on the use of the HART communicator is provided within the HART Appendix in this document.
- For proper HART communication to occur, it is required that a 250-500 ohm resistive load be present in the HC600 analog 4-20 mA signal loop output.

### NOTE

*During alignment adjustment, the HART field communicator may occasionally display a message stating "Non-zero status codes found. Ignore the next 50 occurrences?" When this occurs, enter "Yes", and continue the Fine Alignment procedure.*

## FINE ALIGNMENT ADJUSTMENT USING PARTIAL BEAM BLOCK TOOL

The Partial Beam Block Tool allows fine tuning of HC600 alignment and should be used when the application requires maximum signal strength and low tolerance to potential output drift. Fine tuning the HC600 alignment in this manner ensures that it will operate with maximum immunity from zero drift and false readings.

1. Perform the basic alignment procedure using the Telescope Alignment Tool.
2. Perform a zero calibration on the HC600 receiver. (Zero calibration should be repeated after each alignment adjustment.)
3. Remove the brow from the front of the receiver.
4. Connect the handheld HART communicator to the HC600 receiver module's onboard HART communication port.



**NOTE**

If a HART handheld communicator is not available, the alignment procedure can be performed in a limited way by monitoring the 4-20 mA output. (This method is only partially effective due to the deadband built into the 4-20 mA output.) If the partial beam blocks result in output deflection greater than 4.00 mA +/- 0.1, alignment should be adjusted to eliminate the deflection. The HC600's status LED can also be observed. The LED should remain green with the beam block in any position.

5. Turn on the HART communicator and check for HC600 (OPECL) device recognition. When HART communication is established, the OPGD Rx Root Menu will be displayed on the communicator display.
6. From the Root Menu, select the Status Menu (selection #2).
7. From the Status Menu, select the Sensor Information Menu (selection #3).
8. The Sensor Information Menu will display the following:

1) Active	XXX	
2) Reference	XXX	
3) Ratio	XXX	← Ratio value
4) Gas Gain	X	
5) Absorption	XXX	← Absorption value

(Absorption and Ratio are the readings of interest while performing the alignment procedure.)

**NOTE**

Make alignment adjustments in very small increments. After an adjustment is made, wait for at least 10 seconds for the output level to stabilize. Continue making adjustments, if necessary, until the correct level is achieved.

9. Observe the **Absorption** reading while performing the following steps:
  - A. Perform a series of partial beam blocks to half of the receiver lens using the partial beam block tool (116-009762-002). Block the top, right, bottom, and left halves of the lens individually. Verify that the Absorption level displayed on the HART communicator is as close to zero as possible.
  - B. If an absorption reading greater than +/- 5% is realized, fine adjustment is necessary to achieve optimal alignment. See Figure 20.

**BEAM BLOCK TOP**

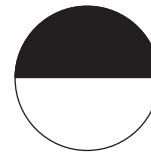

If this block causes Absorption to increase > 5%, move receiver down.

**BEAM BLOCK RIGHT**

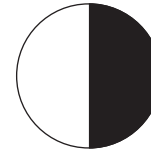

If this block causes Absorption to increase > 5%, move receiver left.

**BEAM BLOCK BOTTOM**

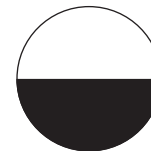

If this block causes Absorption to increase > 5%, move receiver up.

**BEAM BLOCK LEFT**

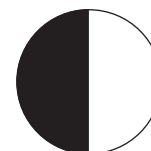

If this block causes Absorption to increase > 5%, move receiver right.

Figure 20—HC600 Beam Block Diagram

C. If adjustments to the receiver were necessary, perform a zero calibration and then repeat the sequence of partial beam blocks. Repeat the adjust, zero calibration, and recheck process until no adjustments to the receiver are necessary, and the partial beam block has little or no effect on the receiver under test.

10. With the beam block tool removed, the **Ratio** reading must be between 0.65 and 0.95. If a reading over 1.0 is indicated, check to make sure that no other transmitters, IR sources, or potential reflections are within view of the receiver. It is possible for multiple transmitters to be viewed by a single receiver. Although each receiver is electronically synchronized to its transmitter, zero drift and/or false gas readings are possible if the rogue IR source continues in the event of a beam block on the primary transmitter. If this situation occurs, a ratio of over 1.0 will be realized. Autronica recommends eliminating any condition that causes a receiver to display a ratio of over 1.0.

11. When correct alignment is achieved, tighten all mounting bolts to 20 lb-ft minimum using care not to disturb the alignment. The telescope can be used during this step to give a visual indication to judge the effects of the tightening process on the alignment. Check the alignment one final time using the beam block tool to verify that the alignment did not change as a result of tightening. If necessary, fine tune the alignment.

12. Upon completion, the HC600 receiver should produce a 4 mA output signal and a green LED indication. If not, ensure that the device has been zero calibrated.

13. Proper operation can be confirmed by bypassing all system alarms, then placing an optical test film (sold separately) into the light beam and checking for the appropriate signal output level on the HART field communicator process menu screen. Test Film p/n 007902-002 should produce an output of 0.75 to 1.5 LFL-Meters. Test Film p/n 116-007902-003 should produce an output of 1.9 to 2.5 LFL-Meters. Alarm conditions, if present, should clear when the test film is removed from the beam.

14. Confirm proper operation by completely blocking the light beam with a solid object such as a piece of cardboard until a beam block fault is generated.

15. Replace the HART port cover and the brow.

16. Restore all system alarms to normal operation.

### GAIN LEVEL CHECK (Optional)

It is necessary to complete the alignment procedure before checking the gain level. A handheld HART communication device is required to check the gain.

#### Procedure

1. Connect the handheld HART communicator to the receiver module's onboard HART communication port.
2. Turn on the HART communicator and check for HC600 (OPECL) device recognition. When HART communication is established, the OPGD Rx Root menu will be displayed on the communicator display.
3. From the Root menu, select the Status Menu (selection #2).
4. From the Status Menu, select the Sensor Information Menu (selection #3).
5. The Sensor Information Menu will display the following screen.
6. Observe the Gas Gain level indicated on the Sensor

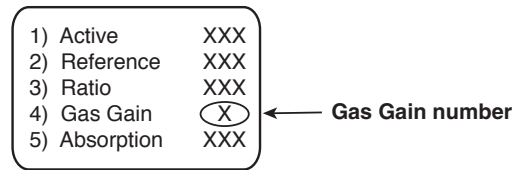

Information Menu screen.

7. Table 4 can be used as a guideline for new installations to assess Gas Gain level with proper alignment.

Table 4— Expected Gas Gain Settings for HC600

Distance (m)	Gain Setting
5	1-3*
20	1*
40	1 - 2
60	2
80	2 - 3
100	3
120	3 - 4

\*Use the Aperture Kit to get desired gain settings.

# CALIBRATION

## CALIBRATION OVERVIEW

Although routine calibration of the HC600 is normally not required, the device supports non-intrusive field zero calibration capability. Span calibration is not required.

### Zero Calibration

Zero Calibration is a one-step process consisting of clean air (zero) condition adjustment only, which is performed automatically by the device. This procedure adjusts the "clean air" signal output only, and is normally used if the 4 milliampere signal level has drifted. The cause of drift is typically due to the presence of background gas during calibration. Ensure that the optical path is clear of hydrocarbons prior to calibration initiation to ensure an accurate zero (clean air) condition.

### IMPORTANT CALIBRATION NOTES

#### NOTE

*Ensure that the detector has been operating for at least two hours before calibrating.*

#### NOTE

*Always ensure that the HC600 optics are totally free of all hydrocarbons before initiating calibration.*

### CALIBRATION INITIATION

Calibration may be initiated by any of the following means:

- The onboard magnetic calibration switch
- Digital communication via MODBUS communication (consult factory for details)
- Remote calibration line.

### Calibration Using Magnetic Switch

The AutoPath HC600 receiver provides an onboard magnetic calibration/reset switch for non-intrusive calibration capability. The magnetic switch is actuated by holding a calibration magnet at the specified location on the device bulkhead. See Figure 2 for switch location. An onboard tri-color LED provides status indication during calibration.

For zero calibration, the magnetic switch must be actuated for 2 seconds to initiate calibration (signaled by a solid red LED). Upon initiation, the HC600 automatically performs the zero calibration adjustment, and then signals with a green LED when this operation is complete.

### Digital Communication Calibration

MODBUS communication may be utilized to initiate HC600 calibration (consult factory).

## DETAILED CALIBRATION PROCEDURE USING MAGNETIC SWITCH

### Zero Calibration

1. Apply magnet for 2 seconds minimum to initiate calibration. (Hold the calibration magnet against the side of the receiver at the location shown in Figure 2.)
  - A. The onboard LED turns to steady red.
  - B. The current output decreases to 1 mA in OPGD-Rx mode or 2.2 mA in PIR9400 mode.
2. When zero calibration is complete:
  - A. The onboard LED changes from steady red to steady green.
  - B. Calibration is complete and current output returns to 4 mA.

## MAINTENANCE

### WARNING

*Do not open cover when an explosive gas atmosphere may be present.*

#### NOTE

*Refer to the OPECL Safety Manual (number 95-8665) for specific requirements and recommendations applicable to the proper installation, operation, and maintenance of all SIL-Certified HC600 IR gas detectors.*

### ROUTINE INSPECTION

The HC600 detector should be inspected periodically to ensure that external obstructions such as plastic bags, mud, snow, or other materials do not block the path and thereby impair the performance of the device.

## OPTICS CLEANING

Cleaning of the HC600 optical surfaces is normally required only if an optical fault is indicated.

Thoroughly douse both window surfaces using a liberal amount of isopropyl alcohol to clear away contaminant particles. Repeat the alcohol flush to remove any remaining contaminants.

### **WARNING**

*Bypass/Inhibit: Volatile organic compounds in cleaning solutions could cause false alarms.*

## PROTECTIVE CAPS AND COVERS

Ensure that the HART Communication Port cover and wiring compartment cover are installed and fully engaged.

## TROUBLESHOOTING

A Fault status is indicated by a yellow LED and also by the 4 to 20 mA output. Refer to Table 5 for assistance in correcting malfunctions with the AutoPath HC600 Detector.

Table 5—Troubleshooting Guide

<b>Fault Condition</b>	<b>Corrective Action</b>
Low 24 volts	24 vdc operating voltage is out of range. Verify proper wiring to the detector and correct voltage output from the power source. Power supply faults are self-clearing when the condition is corrected. If the fault does not clear, consult the factory.
Dirty Optics	Perform cleaning procedure, then recalibrate as required. (Refer to "Maintenance" for details.)
Calibration Fault	If the calibration process is allowed to time-out, the fault is set and can only be reset with a successful calibration.
Negative Signal Output	This fault is indicated when the signal output drops below 0.5 LFL-M. Normally detection capability is not compromised in this condition. The device was probably zero calibrated with background gas present. If the condition persists, purge with clean air and repeat the zero calibration.
Calibration line active at start-up	The only way to clear this fault is to correct the wiring and reapply power. Be sure that the calibration line is not shorted and that the calibration switch is open. If the fault does not clear, consult the factory.
EE Error	If power is interrupted while the unit is updating its internal data logs, an EE Error may occur. Cycling power will correct this fault.
Other Faults	Consult the factory.

## REPLACING HC600 TRANSMITTER/ RECEIVER ELECTRONICS MODULE

### **WARNING**

Do not open when an explosive gas atmosphere may be present.

### **CAUTION**

Only Autronica authorized personnel are allowed to perform this repair.

### **CAUTION**

Replacement of the HC600 transmitter or receiver module requires disassembly of the device housing. Remove power to the device before disassembly.

### **CAUTION**

The HC600 detector contains semiconductor devices that are sensitive to electrostatic discharge (ESD). Use normal precautions for handling ESD sensitive devices. Handle the device by the housing, taking care not to touch electronic components or terminals.

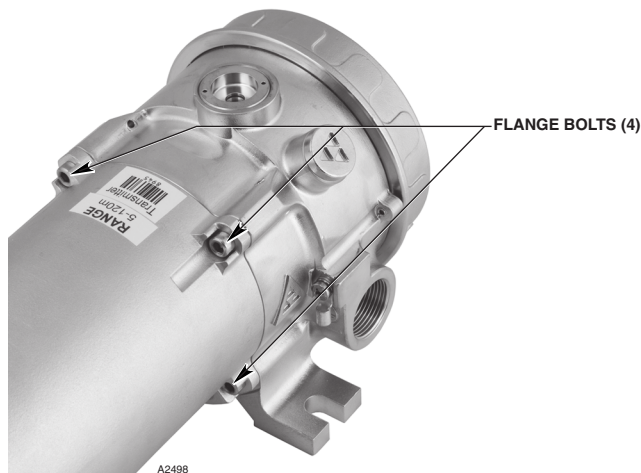

Figure 21— Flange Bolt Location

## MODULE REPLACEMENT PROCEDURE

Tools Required:

- 4 mm hex wrench
- Torque wrench capable of accurately measuring 40 inch-pounds

1. Bypass system alarms as needed, then remove 24 Vdc power from the HC600 detector.
2. Remove the four stainless steel flange bolts using a 4 mm hex wrench. See Figure 21. Take care to properly support the module as the last flange bolt is removed.
3. Carefully remove the old module by extracting it straight out from the bulkhead.

### **CAUTION**

Handle the new module carefully to prevent damage. Since both the lens and circuit board protrude beyond the edge of the housing, the module should only be set down on its side to prevent damage to the lens or circuit board.

4. Ensure that the o-ring on the replacement module is present, undamaged, and correctly seated in the groove on the housing. See Figure 22. This o-ring is required to maintain the watertight integrity of the HC600 housing.

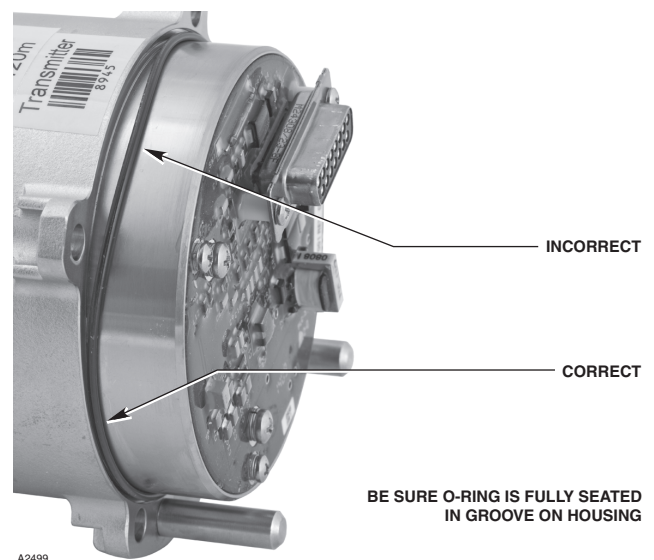

Figure 22—O-Ring on HC600 Module



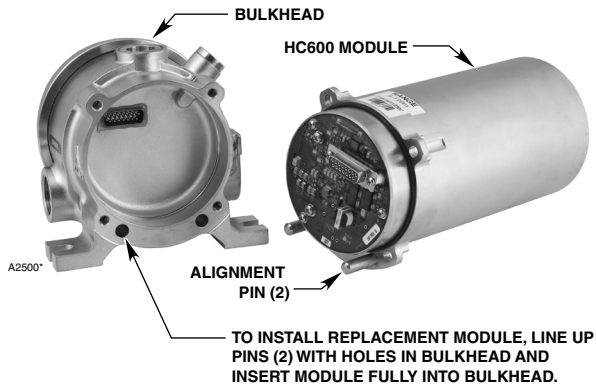

Figure 23—HC600 Module Removed from Bulkhead

5. Line up the two pins on the replacement module with the two holes in the bulkhead and insert the module straight into the bulkhead. See Figure 23.
  6. Insert and tighten the four flange bolts in an opposing consecutive order in two stages — first partially tighten all four bolts equally, and then fully tighten each bolt in an opposing order to 40 inch-pounds (4.5 Nm) of torque. Bolts are M6 per ISO 965 with M5 head, SST with a yield stress of 448 N/mm<sup>2</sup> (65.00 PSI) minimum.
- CAUTION**
- Flange bolts are critical to maintaining the flameproof properties of the HC600. If replacement flange bolts are needed, spare part number 116-007167-001 must be used in order to maintain the integrity of the enclosure. The use of any other bolts will void the Ex d certification of the HC600.*
7. When all equipment has been properly installed, ensure that system alarms are appropriately bypassed and apply power to the system.
  8. Perform the alignment procedure as previously described in this manual.

**IMPORTANT**

*If the HC600 module had an aperture installed, install the aperture before performing the alignment procedure (install apertures on the transmitter, not on the receiver). If the separation distance is between 5 and 30 meters and signal saturation is indicated after completion of the Basic Alignment procedure, an aperture will be required (even if no aperture was originally installed). Refer to the "Aperture Kit for Short Range Applications" section in this manual for complete information regarding apertures.*

9. Perform a zero calibration of the detector.
10. Upon completion of zero calibration, verify proper operation by performing an "optical test film test" and also a "beam block test" as previously described in this manual.

**NOTE**

*Replacement receiver modules are furnished from the factory with default configuration settings. If the HC600 system has had any configuration changes in the field, the new receiver will require changes to configuration parameters using a HART communicator or a FlexVu UD10 display unit.*

11. Restore system alarms (remove bypass).

## DEVICE REPAIR AND RETURN

The AutoPath HC600 IR Hydrocarbon Gas Detector is not designed to be repaired in the field. If a problem should develop, first carefully check for proper wiring, programming and calibration. If it is determined that the problem is caused by an electronic failure, the device must be returned to the factory for repair.

Prior to returning devices, contact the nearest local Autronica office so that a Return Material Identification (RMI) number can be assigned. **A written statement describing the malfunction must accompany the returned device or component to assist and expedite finding the root cause of the failure.**

Pack the unit properly. Always use sufficient packing material. Where applicable, use an antistatic bag as protection from electrostatic discharge.

**NOTE**

*Inadequate packaging that ultimately causes damage to the returned device during shipment will result in a service charge to repair the damage incurred during shipment.*

Return all equipment transportation prepaid to the factory in Trondheim.

## ORDERING INFORMATION

When ordering, please refer to the HC600 Model Matrix:

### ALIGNMENT EQUIPMENT

Part Number	Description
116-009104-001	HC600 Alignment Telescope — Consists of a 32mm sighting device with 3-9x zoom magnifier that is factory assembled with precision holder and reflective mirror, and partial beam block tool.
116-009762-002	Partial Beam Block Tool (included with 116-009104-001)

### ACCESSORIES

Part Number	Description
116-009296-001	Short Range Aperture kit — Delrin plastic (included with receiver)
116-008987-001	Short Range Aperture kit — Stainless Steel (optional)
116-009761-001	Thermal Shield for one module (two shields required per system)
116-007902-002	System Test Film (0.75–1.5 LFL-Meters signal output)
116-007902-003	System Test Film (1.9–2.5 LFL-Meters signal output)
116-103922-001	Model 475 HART handheld communicator*
116-103922-002	Model 475 HART/Foundation Fieldbus handheld communicator*
116-000118-010	Remote HART Port Kit
116-009246-001	Low Range HC600 Gas Test Cell
116-009246-002	High Range HC600 Gas Test Cell *includes HC600 config software

## SPARE PARTS

Part Number	Description
116-102740-002	Calibration Magnet
116-005003-001	Silicone Free Grease
116-107427-040	O-Ring, 3.75" i.d., for wiring compartment cover
116-107427-053	O-Ring, 3.25" i.d., for front flange (internal)
116-007167-001	M6 Flange Bolt
116-009186-001	Spare Pan-Tilt Mounting Kit (for one HC600 module only)
116-008925-002	Spare electronics/lamp module for HC600 transmitter
116-008926-002	Spare electronics module for HC600 receiver (relay/4-20 version)
116-103578-001	Anti-seize Lubricant Packet

## ASSISTANCE

For assistance in ordering a system to meet the needs of a specific application, contact:

Autronica Fire and Security AS  
P.O.Box 5620  
NO-7043 Trondheim  
Operator: (47) 73 58 25 00  
Fax: (47) 73 58 25 01  
Web site: [www.autronicafire.com](http://www.autronicafire.com)  
E-mail: [info@autronicafire.no](mailto:info@autronicafire.no)

**HC600 MODEL MATRIX**

MODEL	DESCRIPTION								
HC600	AutoPath HC600 Infrared Gas Detector								
	<table border="1"> <thead> <tr> <th>TYPE</th> <th>MATERIAL</th> </tr> </thead> <tbody> <tr> <td>S</td> <td>Stainless Steel</td> </tr> </tbody> </table>	TYPE	MATERIAL	S	Stainless Steel				
TYPE	MATERIAL								
S	Stainless Steel								
	<table border="1"> <thead> <tr> <th>TYPE</th> <th>CONDUIT ENTRY THREAD TYPE</th> </tr> </thead> <tbody> <tr> <td>2M</td> <td>2 Port, Metric M25</td> </tr> <tr> <td>2N</td> <td>2 Port, 3/4" NPT</td> </tr> </tbody> </table>	TYPE	CONDUIT ENTRY THREAD TYPE	2M	2 Port, Metric M25	2N	2 Port, 3/4" NPT		
TYPE	CONDUIT ENTRY THREAD TYPE								
2M	2 Port, Metric M25								
2N	2 Port, 3/4" NPT								
	<table border="1"> <thead> <tr> <th>TYPE</th> <th>OUTPUT</th> </tr> </thead> <tbody> <tr> <td>00</td> <td>None (Transmitter only)</td> </tr> <tr> <td>18</td> <td>4-20 mA, RS485, HART (Receiver or Kit)</td> </tr> <tr> <td>25</td> <td>4-20 mA, RS485, HART w/Optional Relay Board (Receiver or Kit) – <b>Ex d only</b></td> </tr> </tbody> </table>	TYPE	OUTPUT	00	None (Transmitter only)	18	4-20 mA, RS485, HART (Receiver or Kit)	25	4-20 mA, RS485, HART w/Optional Relay Board (Receiver or Kit) – <b>Ex d only</b>
TYPE	OUTPUT								
00	None (Transmitter only)								
18	4-20 mA, RS485, HART (Receiver or Kit)								
25	4-20 mA, RS485, HART w/Optional Relay Board (Receiver or Kit) – <b>Ex d only</b>								
	<table border="1"> <thead> <tr> <th>TYPE</th> <th>APPROVALS</th> </tr> </thead> <tbody> <tr> <td>B</td> <td>INMETRO (Brazil)</td> </tr> <tr> <td>E</td> <td>ATEX/CE/IECEX</td> </tr> </tbody> </table>	TYPE	APPROVALS	B	INMETRO (Brazil)	E	ATEX/CE/IECEX		
TYPE	APPROVALS								
B	INMETRO (Brazil)								
E	ATEX/CE/IECEX								
	<table border="1"> <thead> <tr> <th>TYPE</th> <th>CLASSIFICATION</th> </tr> </thead> <tbody> <tr> <td>1</td> <td>Division/Zone Ex d e ([ib] receiver only)</td> </tr> <tr> <td>2</td> <td>Division/Zone Ex d ([ib] receiver only)</td> </tr> </tbody> </table>	TYPE	CLASSIFICATION	1	Division/Zone Ex d e ([ib] receiver only)	2	Division/Zone Ex d ([ib] receiver only)		
TYPE	CLASSIFICATION								
1	Division/Zone Ex d e ([ib] receiver only)								
2	Division/Zone Ex d ([ib] receiver only)								
	<table border="1"> <thead> <tr> <th>TYPE</th> <th>CONFIGURATION</th> </tr> </thead> <tbody> <tr> <td>S</td> <td>Transmitter/Receiver/Mounting Hardware</td> </tr> <tr> <td>T</td> <td>Transmitter Module Only</td> </tr> <tr> <td>R</td> <td>Receiver Module Only</td> </tr> </tbody> </table>	TYPE	CONFIGURATION	S	Transmitter/Receiver/Mounting Hardware	T	Transmitter Module Only	R	Receiver Module Only
TYPE	CONFIGURATION								
S	Transmitter/Receiver/Mounting Hardware								
T	Transmitter Module Only								
R	Receiver Module Only								



# APPENDIX A

## ATEX APPROVAL DESCRIPTION

The following items, functions and options describe the ATEX approval.

### APPROVAL

AutoPath HC600 Infrared Hydrocarbon Gas Detector.

#### Receiver

CE 0539 II 2 G  
DEMKO 06 ATEX 141002X  
Ex d e [ib] IIC T5 Gb  
T5 (Tamb -50°C to +60°C)  
EN 60079-29-4 IP66/IP67.  
IP66/IP67.

(Receiver without relays)

--OR--

Ex d [ib] IIC T5 Gb  
T5 (Tamb -55°C to +60°C)  
EN 60079-29-4  
IP66/IP67.

(Receiver with relays)

Performance verified in accordance with EN 60079-29-4.

HART Communication Port:

Uo = 4.0V Co = 20µF

Io = 100mA Lo = 500µH

#### Transmitter

CE 0539 II 2 G  
DEMKO 06 ATEX 141002X  
Ex d e IIC T5 Gb  
T5 (Tamb -50°C to +60°C)

--OR--

Ex d IIC T5 Gb  
T5 (Tamb -55°C to +60°C)  
IP66/IP67.

### ATEX Special Conditions for Safe Use (general):

- The measuring function of the Infrared Hydrocarbon Gas Detector HC600, as a safety device in accordance to Annex II Clause 1.5.5, 1.5.6 and 1.5.7 of the Directive 94/9/EC, for methane is covered in this certificate.
- The ambient temperature range is limited to -50°C to +60°C for the Ex d e [ib] IIC T5, Ex d e IIC T5 version, and -55°C to +60°C for the Ex d [ib] IIC T5, Ex d IIC T5 version.
- Only suitable certified Ex d or Ex e (as applicable) cable entries and blanking elements are to be used.
- The HC600 assemblies are to be installed in places where there is a low risk of mechanical damage.
- The field wiring terminal connections are certified for a single wire in size from 0.2 to 2.5 mm<sup>2</sup>, (or two conductors with same cross section 0.2 to 0.75 mm<sup>2</sup>). The screws must be tightened down with a torque 0.4 to 0.5 Nm.
- The metal housing of the HC600 Gas Detector must be electrically connected to earth ground.

**ATEX Special Conditions for Safe Use for the [ib] HART communication port only:**

- The intrinsically safe output on the HART Communicator Port is internally connected to frame.
- The HC600 Infrared Hydrocarbon Gas Detector shall be powered from a SELV isolating transformer according to EN 60742 or EN 61588.
- Um is restricted to 250 V, prospective short circuit current < 1500 A.
- The maximum cable distance between the HART communicator and the HC600 Infrared Hydrocarbon Gas Detector is 610 meters.

**WARNING**

*Always ensure that the detector/junction box hazardous (classified) location ratings are applicable for the intended use.*

**Additional Safety Notes:**

- For ambient temperatures below -10°C, use field wiring suitable for the expected conditions, and for ambient temperatures above +60°C, use field wiring suitable for 20°C above the maximum expected conditions.

**ATEX Standards:**

EN 50241-1/A1: 2004

EN 50241-2: 1999

EN 60079-29-4: 2010

Performance Approved for Methane

EN 60079-0: 2009

EN 60079-1: 2007

EN 60079-7: 2007

EN 60079-11: 2007

EN 60529:1991+A1:2000

EN 50270: 2006

EN 50271: 2010

**CE: Conforms to:**

Low Voltage Directive: 2006/95/EC,

EMC Directive: 2004/108/EC,

ATEX Directive: 94/9/EC, WEEE 2002/96/EC.

**ACCURACY** (per EN 60079-29-4)

4-20 mA Model:  $\pm 0.25$  LFL-meters or  $\pm 12.4\%$  of applied gas concentration, whichever is greater, with water vapor @  $\geq 82^{\circ}\text{C}$ .

**RESPONSE TIME**

4-20 mA Model

T50: 1.2 seconds (2.5 LFL-meters applied)

T90: 2.5 seconds (2.5 LFL-meters applied).

**ALIGNMENT**

Misalignment will cause the manufacturer stated accuracy limits to increase, but remain within the limits of EN 50241-1, -2 and EN 60079-29-4.

## APPENDIX B

### IECEX APPROVAL DESCRIPTION

The following items, functions and options describe the IECEx approval.

#### APPROVAL

AutroPath HC600 Infrared Hydrocarbon Gas Detector.

##### Receiver

IECEX ULD 05.0001X  
Ex d [ib] IIC T5 Gb  
T5 (T<sub>amb</sub> -55°C to +60°C)  
--OR--  
Ex d e [ib] IIC T5 Gb.  
T5 (T<sub>amb</sub> -50°C to +60°C)  
IP66/IP67.  
HART Communication Port:  
U<sub>0</sub> = 4.0V C<sub>0</sub> = 20µF  
I<sub>0</sub> = 100mA L<sub>0</sub> = 500µH  
U<sub>m</sub> = 250V

##### Transmitter

IECEX ULD 05.0001X  
Ex d IIC T5 Gb  
T5 (T<sub>amb</sub> -55°C to +60°C)  
--OR--  
Ex d e IIC T5 Gb.  
T5 (T<sub>amb</sub> -50°C to +60°C)  
IP66/IP67.

IEC Standards:

IEC 60079-0: 2007  
IEC 60079-1: 2007  
IEC 60079-7: 2006  
IEC 60079-11: 2006  
IEC 60529, 2.1 ed.+Corr.1:2003+2:2007  
IEC 61000-4-3: 2006

#### IEC Conditions of Certification (general):

- The ambient temperature range is limited to -50°C to +60°C for the Ex d e [ib] IIC T5, Ex d e IIC T5 version, and -55°C to +60°C for the Ex d [ib] IIC T5, Ex d IIC T5 version.
- Only suitable certified Ex d or Ex e (as applicable) cable entries and blanking elements are to be used.
- The HC600 assemblies are to be installed in places where there is a low risk of mechanical damage.
- The field wiring terminal connections are certified for a single wire in size from 0.2 to 2.5 mm<sup>2</sup>, (or two conductors with same cross section 0.2 to 0.75 mm<sup>2</sup>). The screws must be tightened down with a torque 0.4 to 0.5 Nm.
- The metal housing of the HC600 Gas Detector must be electrically connected to earth ground.

**Special Conditions for Safe Use for the [ib] HART communication port only:**

- The intrinsically safe output on the HART Communicator Port is internally connected to frame.
- When connecting to a circuit using up to 1% of Co or Lo, then the C or L is limited to the Co and Lo listed above. If either the C or L is above 1% of Co or Lo, then C or L are each limited to 50% of the Co or Lo listed above.
- Um is restricted to 250 V, prospective short circuit current < 1500 A.

**WARNING**

*Always ensure that the detector/junction box hazardous (classified) location ratings are applicable for the intended use.*

**Additional Safety Notes:**

- For ambient temperatures below  $-10^{\circ}\text{C}$ , use field wiring suitable for the expected conditions, and for ambient temperatures above  $+60^{\circ}\text{C}$ , use field wiring suitable for  $20^{\circ}\text{C}$  above the maximum expected conditions.

**ACCURACY** (per IEC 60079-29-4)

4-20 mA Model:  $\pm 0.25$  LFL-meters or  $\pm 12.4\%$  of applied gas concentration, whichever is greater, with water vapor @  $\geq 82^{\circ}\text{C}$ .

**RESPONSE TIME**

**4-20 mA Model**

T50: 1.2 seconds (2.5 LFL-meters applied)

T90: 2.5 seconds (2.5 LFL-meters applied).

**ALIGNMENT**

Misalignment will cause the manufacturer stated accuracy limits to increase, but remain within the limits of IEC 60079-29-4.

## **APPENDIX C**

### **OTHER APPROVALS**

The following items, functions and options describe various other approvals applicable to the HC600.

#### **INMETRO (Brazil)**

Certificate No. UL-BR 12.0128X

Ex d IIC T5 Gb IP66/67 (Tamb: -55°C to +60°C

- OR -

Ex de IIC T5 Gb IP66/67 (Tamb: -50°C to +60°C

- OR -

Ex d [ib] IIC T5 Gb IP66/67 (Tamb: -55°C to +60°C

- OR -

Ex de [ib] IIC T5 Gb IP66/67 (Tamb: -50°C to +60°C

## APPENDIX D

### HART COMMUNICATION

Digital communication with the AutoPath HC600 is necessary to monitor internal status and to modify the factory settings. This appendix provides guidance on establishing HART communication, and describes the communication menu structure when using the AutoPath HC600 with the HART Handheld Communicator.

#### INTERCONNECTING THE HART COMMUNICATOR WITH THE AUTOPATH HC600

Unscrew the protective cap from the HART communication port on the side of the AutoPath HC600 receiver. Connect the HART Communicator to the two terminals inside the port. Press the "on" key to switch on the HART Communicator. The Online menu is the first menu to appear when the Communicator is properly connected to the AutoPath HC600. This menu is structured to provide important information about the connected device immediately on powering up the Communicator. This menu displays up-to-date device information including primary variable, analog output, lower range value, and upper range value.

#### NOTE

*The HART protocol incorporates a concept called the "Device Description Language" that enables all suppliers of HART instruments to define and document their products in a single consistent format. This format is readable by handheld communicators, PC's and other process interface devices that support DDL. DDL enables full interoperability of devices, regardless of manufacturer, allowing full functionality from any HART device.*

In the event that your Communicator does not establish communications with the AutoPath HC600, you may need to ensure that the appropriate DDLs for the OPECL are included within your Communicator. To review the device descriptions programmed into your HART Communicator:

1. From the Main menu, press to access Offline menu.
2. From the Offline menu, press New Configurations to access the list of device descriptions programmed into your HART Communicator. The Manufacturer menu displays a list of each manufacturer with device descriptions currently installed in your Communicator's Memory Module. The standard 12 MB Memory Module is recommended, as it allows for more device descriptions.
3. Select a manufacturer, and the Model menu displays, containing a list of currently installed device models provided by the selected manufacturer.
4. Review the different manufacturers and models to determine the installed HART-compatible devices in your Communicator.

If you cannot find the OPECL device on your Communicator, the device revision you are looking for is not programmed into the Memory Module. In this instance, you are limited to what is available using the generic interface built into your HART Communicator.

The HART Communication Foundation ([www.ccsi.com/hart](http://www.ccsi.com/hart)) manages a library of Manufacturer Device Descriptions, which are distributed to programming sites for inclusion in master devices. A complete listing of the HCF DD Library is available for download in manufacturer and device type sequence.

#### NOTE

*If a device is found, the HART Communicator displays the Online menu. If no device is found, the Communicator displays the Main menu. If no device is found, check the connections, verify the presence of a minimum of 250 ohms load resistance in series in the loop, and retry by selecting 'Online.' To poll multiple devices in the loop, refer to the HART Communicator manual.*





## CONNECTIONS AND HARDWARE

The HART Communicator can interface with the AutoPath HC600 from the onboard I.S. communication port, from the control room, or from any wiring termination point in the analog output signal loop. To communicate, connect the HART communicator in parallel with the AutoPath HC600 analog signal or load resistor. The connections are non-polarized.

### NOTE

*The HART Communicator needs a minimum of 250 ohms resistance in the loop to function properly. The HART Communicator does not measure loop current directly.*

## ONLINE MENU

When HART communication is established with the receiver, the first menu displayed is the OPGD RX Root menu:

### OPGD RX Root Menu

- 1) Process Menu
- 2) Status Menu
- 3) Setup Menu
- 4) Calibration Menu
- 5) Test Menu

To select any of the 5 menu options shown, highlight the desired option using the up/down arrow key, and then press the "right arrow" key.

## COMMONLY USED HART COMMANDS

The most commonly used HART commands for the HC600 are:

1. Setting the real time clock
2. Setting alarm thresholds & latch/nonlatch functions
3. Setting the analog fault code menu
4. Performing full system alignment
5. Performing zero calibration
6. Assigning a nonvolatile tag name to the receiver
7. Defining a nonvolatile descriptor for future reference
8. Interrogating the history menu for information including total running hours, max/min temperature, calibration and event logs.