

ESPA interface module - BSL-333

AutoSafe interactive fire detection system
Product datasheet

Features

- Interfaces AutoSafe interactive fire detection system (with software version 3.2.0 or newer) to interface on site wireless pagers, off site GSM telephone or hospital nurse call systems
- Transmission of fire alarms, prealarms, faults and technical alarms
- Two serial ports: Port 1 and Port 2; isolated from each other and from the power supply
- Port 1 is RS232; Port 2 is RS232
- DIN rail enclosure with removable screw terminals; fits 35mm symmetric rails
- DC power input in the range +7V to +35V; uses a high efficiency switching power supply

Applications

The ESPA interface module BSL-333 is an RS232 interface module used to interface on site wireless pagers. By means of an additional unit it can also interface off-site GSM telephones. The ESPA Interface Module supports a large number of paging systems with ESPA 4.4.4 protocol.

The following messages can be transmitted (from an AutoSafe fire alarm panel):

- fire alarms
- prealarms
- faults
- technical alarms from I/O units

Texts from AutoSafe may include the name of a Detection zone and/or Operation zone, Tag names (point information), plus general fault texts.

The type of message to be transmitted to each pager is configurable, as well as the number of pagers the messages are transmitted to. Typically, a system will be configured to transmit all types of messages to some pagers, and only fire alarm messages to other pagers.

The same type of pagers must be used within a system. A large number of pagers or group numbers can be used.

The module is connected to the AutoSafe via the AutoCom protocol. The serial port communication board EAU-321 uses one port. The communication is set at 9600 baud, 8 data bits, no parity and 1 stop bit.

Requirements

The use of BSL-333 requires AutoSafe software version 3.2.0 or newer and the serial port communication board EAU-321. The ESPA service package is required to configure and commission the system.

Connections and termination

PORT 1		PORT 2	
Terminal no.	Signal	Terminal no.	Signal
1	TX	1	TX
2	n.c.	2	
3	RX	3	RX
4	n.c.	4	
5	n.c.	5	n.c.
6	P1.GND	6	P2.GND
7	24V DC		
8	0V		



Indicators and buttons

BSL-333 has the following indicators and buttons:

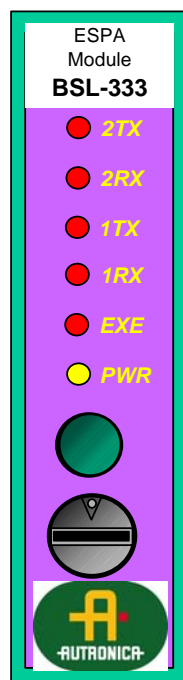

- Red LED - Send (TX) port 2 (to pager). Blinking light (0,5 second intervals) indicates that signals are being sent.
- Red LED - Receive (RX) port 2 (to pager). Blinking light (0,5 seconds intervals) indicates that signals are being received.
- Red LED - Send (TX) port 1 (to EAU-321 – AutoSafe). Blinking light (3 seconds intervals) indicates that signals are being sent.
- Red LED - Receive (RX) port 1 (to EAU-321 – AutoSafe). Blinking light (3 seconds intervals) indicates that signals are being received.
- Red LED – Executive mode (when setting parameters) Blinking light (1 second intervals) when green button has been pressed.
- Normal operation: EXE lights steady while a message is sent to the paging system
- Yellow LED – Steady light indicates power ON.
- Green Executive mode button. Used to enter Executive mode (when setting parameters).
- Grey rotary switch (default factory settings - 0).



Technical specifications	
Mounting	Mounted on rail. DIN rail enclosure with removable screw terminals; fits 35mm symmetric rails
Ports	Two asynchronous ports, TX & RX signals only.
Interface Options	Port 1 is RS232; port 2 is RS232.
RS232	Receiver threshold + 1.5V typ. Receiver Rin 5kΩ typ. TX o/p ±8V typ (3k load).
Power supply	+ 7V to + 35 VDC. + 12 VDC Input power approx. constant at 1-2 watts (startup current 300-600mA) depending on model. At startup, the supply voltage must reach 7V in <1 sec.
Isolation	64V PK, tested at >1000V AC RMS, 1 second.
Environmental	Operating temperature 0 to +50°C. Storage temperature -25°C to + 70°C. Relative humidity (operating and storage) 0 to 90%, non condensing.
EMC compliance	Emissions EN 50081-2 (94), immunity EN 50082-2 (95).

Part number	Description
116-AS-ESPAPACK	<i>Complete pack including:</i> ■ BSL-333 ■ EAU-321 (without std. flat cable and termination block) ■ Cable XBA-055 (between EAU-321 and BSL-333) The separate AS-ESPASERVPACK is required for configuration and commissioning.
116-AS-ESPAMODULE	<i>Includes:</i> ■ BSL-333 ■ Cable XBA-055 (between EAU-321 and BSL-333) ■ Documentation (hardcopies) The separate AS-ESPASERVPACK required for configuration and commissioning. The EAU-321 board is <i>not</i> included, as this pack is intended to be used when the board is already installed.
116-AS-ESPASERVPACK	<i>Complete service pack used for the configuration and commissioning of BSL-333, plus testing of the module when it has been installed, including:</i> ■ CD-ROM with 3 programs (The KD485 Configuration program, AutoCom test program, the pager tester) and documentation (pdf-files) ■ 2 test cables for connection between the BSL-333 and the computer.
116-AS-ESPACD	<i>Includes:</i> ■ CD-ROM with 3 programs (The KD485 Configuration program, AutoCom test program, the pager tester) ■ Documentation (pdf-files)
116-BSL-333	■ BSL-333 (spare part) ■ Documentation (paper)

Dimensions (mm)

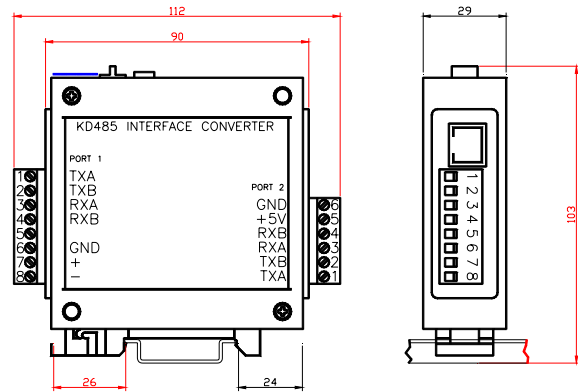

Schematics / cable connections overview

Dipswitches

The illustration below shows the dipswitch settings on BSL-333.

Top View of BSL-333 Module

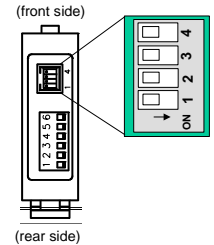

Overview – Typical Installation

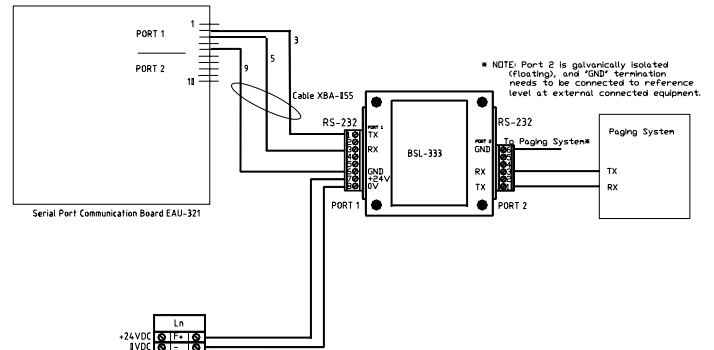

ESPA interface module BSL-333

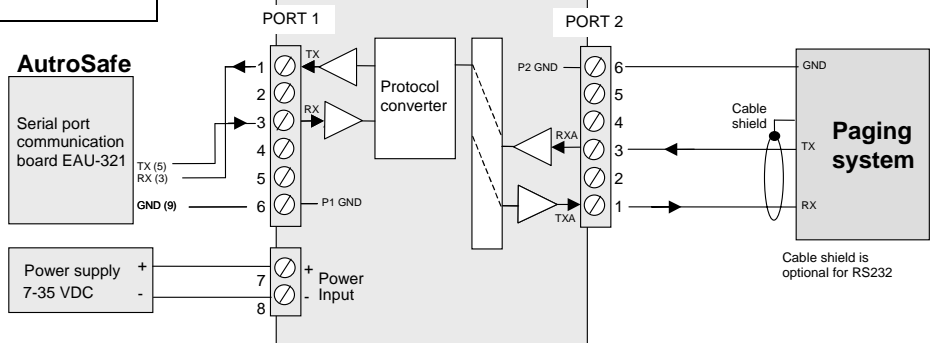

AUTRONICA FIRE AND SECURITY AS

Head office, NO-7483 Trondheim, Norway Tel: +47 73 58 25 00, fax: +47 73 58 25 01, e-mail: info@autronicafire.no
 Oil and Gas division, Stavanger, Norway Tel: +47 51 84 09 00, fax: +47 51 84 09 99
 Maritime division, Spikkestad, Norway Tel: +47 31 29 55 00, fax: +47 31 29 55 01

Visit Autronica Fire and Security AS' website: www.autronicafire.com